



**aluplast GmbH**  
uPVC window profile systems

Auf der Breit 2 | DE-76227 Karlsruhe  
Tel. +49 (721) 47171-0 | Fax -999  
info@aluplast.de | www.aluplast.de

**IDEAL 8000**<sup>®</sup>  
2011-10

<b>01 General Information</b>				<b>page(s)</b>	<b>filename(s)</b>
<b>01 A Material properties</b>				1	01_A_01_ID*
<b>01 B System description</b>				1 - 3	01_B_01_2*
<b>01 E Product data specifications</b>				1 - 4	01_E_01_2*
<b>01 G Overview window types</b>				1 - 4	01_G_01_ID*
<b>01 P Plans of profiles</b>					
IDEAL 8000					
Additional profiles 1					
Additional profiles 2					
Glazing beads					
Accessories IDEAL 2000-8000					
Aluminium shells					
Reinforcements					

---

<b>02 Main Profiles: Overview</b>				<b>page(s)</b>	<b>filename(s)</b>	
<b>02 B Frames</b>				(scale 1:1)	1 - 4	02_B_01_8*
080x05	80mm	(CL)	powerdur, frame	1		
180x05	80mm	(CL)	frame	2		
180x04	100mm	(CL)	frame	3		
180x03	80mm	(RL)	frame	4		
<b>02 C Sashes</b>				(scale 1:1)	1 - 9	02_C_01_8*
080x86	77mm	fv. (CL)	powerdur, bonding, sash	1		
180x20	77mm	fv. (CL)	sash	2		
180x30	105mm	fv. (CL)	sash	3		
180x31	105mm	fv. (CL)	opening outwards, sash	4		
180x26	77mm	hfv. (CL)	extended rebate, sash	5		
180x22	77mm	fv. (RL)	sash	6		
180x83	77mm	fv. (RL)	bonding, sash	7		
180x32	105mm	fv. (RL)	sash	8		
180x85	77mm	hfv. (RL)	bonding, sash	9		
<b>02 D Mullions / Transoms</b>				(scale 1:1)	1 - 5	02_D_01_8*
180x44	104mm	(CL)	mullion	1		
180x43	104mm	(RL)	mullion	2		
180x46	70mm	(CL)	transom	3		
180x47	70mm	(CL)	extended rebate, transom	4		
180x45	104mm	(RL)	transom	5		
<b>02 E False mullion sash / False mullion profiles</b>				(scale 1:1)	1 - 4	02_E_01_8*
180x69	87mm	hfv. (CL)	extended rebate, false mullion sash	1		
180x66	84mm	(CL)	big false mullion	2		
180x64	64mm	(CL)	small false mullion	3		
180x65	64mm	(RL)	small false mullion	4		

<b>03 Main Profiles: Combinations</b>	<b>page(s)</b>	<b>filename(s)</b>
<b>03 A Construction dimensions</b>	1 - 3	03_A_01_8*
<b>03 B Balcony/side entrance door thresholds (scale 1:2)</b>	1 - 2	03_B_01_8*
<b>03 C Tilt-and-turn door thresholds<sup>2)</sup></b>	1 - 3	03_C_01_8*
<b>03 D Frame<sup>1)</sup> - Sash<sup>2)</sup></b>	1 - 36	03_D_01_8*
<b>03 E Frame<sup>1)</sup> - Fixed glazing</b>	1 - 4	03_E_01_8*
<b>03 G Sash<sup>2)</sup> - Mullion<sup>1)</sup> - Sash<sup>2)</sup></b>	1 - 18	03_G_01_8*
<b>03 H Sash<sup>2)</sup> - Mullion<sup>1)</sup> - Fixed glazing</b>	1 - 18	03_H_01_8*
<b>03 J Mullions<sup>1)</sup> glazing-divisive</b>	1 - 2	03_J_01_8*
<b>03 K Transoms<sup>1)</sup> glazing-divisive</b>	1 - 3	03_K_01_8*
<b>03 L Sash<sup>2)</sup> - False mullion<sup>1)</sup> - Sash<sup>2)</sup></b>	1 - 27	03_L_01_8*
<b>03 M False mullion sash<sup>1)</sup> - Sash<sup>2)</sup></b>	1 - 1	03_M_01_8*
<b>03 Z Examples for structure connections (scale 1:1/2)</b>	1 - 12	03_Z_01_8*

<sup>1)</sup> Profiles are sorted numerically within the chapters.

<sup>2)</sup> Sashes are sorted numerically within the chapters.

1)				2)								
chapter: 03 D		03 E		chapter: 03 G		03 H		chapter: 03 L		no. sash		
no.	frame	pages	pages	no.	mullion	pages	pages	no.	false mullion	pages		
1	080x05	9	1	1	180x43	9	9	1	180x64	9	1 080x86	
2	180x03	9	1	2	180x44	9	9	2	180x65	9	2 180x20	
3	180x05	9	1	pages:		18	18	3	180x66	9	3 180x22	
4	180x05	9	1					pages:		27	4 180x26	
pages:		36	4	chapter: 03 J				chapter: 03 M				
				no.	mullion	pages			no.	false mullion	pages	5 180x30
				1	180x43	1			1	180x69	1	6 180x31
				2	180x44	1			pages:		1	7 180x32
				pages:		2						8 180x83
				chapter: 03 K								9 180x85
				no.	transom	pages						
				1	180x45	1						
				1	180x46	1						
				1	180x47	1						
				pages:		3						

<b>04 Additional Profiles</b>	<b>page(s)</b>	<b>filename(s)</b>
See manual: IDEAL Additional Profiles / Accessories		
<b>05 Accessories</b>	<b>page(s)</b>	<b>filename(s)</b>
See manual: IDEAL Additional Profiles / Accessories		
<b>06 Reinforcement Guidelines / Statics</b>	<b>page(s)</b>	<b>filename(s)</b>
See manual: IDEAL General Handling Directions		
<b>07 - - -</b>	<b>page(s)</b>	<b>filename(s)</b>
Currently not available!		
<b>08 General Handling Directions</b>	<b>page(s)</b>	<b>filename(s)</b>
See manual: IDEAL General Handling Directions		
<b>09 Individual Handling</b>	<b>page(s)</b>	<b>filename(s)</b>
<b>09 H Mechanical connections</b> (Content: 09 H 01)	1 - 7 8 - 10	09_H_01_8* 09_H_02_8*
<b>09 J Handling Thresholds / Doors</b>	1 - 3	09_J_01_8*
<b>09 Z Cutting dimensions false mullion</b>	1 - 4	09_Z_01_8*
<b>10 General Installation Guidelines</b>	<b>page(s)</b>	<b>filename(s)</b>
See manual: IDEAL General Handling Directions		

**Abbreviations (availability depends on profile serial):**

Design: (CL) Classic-line / (SL) Soft-line / (RL) Round-line / (HL) Historik-line  
 Profile type: (MB) Monoblock or block profile: frame group(s) with integrated frame profile  
 Regional profiles: (A) Austria / (CH) Switzerland / (NL) Netherlands  
 Sash plane to frame: fv. recessed / hf.v. semi-recessed/ fb. flush

**Annotation to chapter 03 Combinations:**

The page number is made up of the last two to three figures of profile 1 (e.g. frame or mullion or false mullion) and the last two figures of profile 2 (e.g. sash). If there is no profile 2, abbreviations are used (e.g. FV for fixed glazing). On that way, a numeric order of the chapters and within the chapters results.

Examples: chapter / **page 03 D 05-86** = chapter 03 D frame - sash = with frame 080x05 and sash 080x86  
 chapter / **page 03 D 05-30** = chapter 03 D frame - sash = with frame 080x05 and sash 180x30  
 ... etc.  
 chapter / **page 03 D 05-85** = chapter 03 D frame - sash = with frame 080x05 and sash 180x85  
 chapter / **page 03 D 03-86** = chapter 03 D frame - sash = with frame 180x03 and sash 080x86  
 ... etc.

## Material Properties

According to DIN EN ISO 1163, aluplast uses the following uPVC-moulding compound as profile system material:

### ISO 1163 - PVC-U, EDLP, 082-50-T28

Iso standard DIN EN ...	↑
PVC = polyvinyl chloride	↑
U = plasticiser-free (rigid)	↑
E = extrusion	↑
D = powder (Dryblend)	↑
L = light and weathering stabiliser	↑
P = impact-resistant modified	↑
082 = Vicat-softening temperature: 80 - 84 °C	↑
50 = impact strength: >40 kJ/m <sup>2</sup>	↑
T28 = modulus of elasticity: 2500 - 3000 N/mm <sup>2</sup> (tensile modulus = tension = T)	↑

The utilised recipe is free of cadmium and barium.  
Other versions / consignments according to system description or on request.

#### Characteristics CaZn (calcium zinc)

according to standard(s):	Description:	Unit:	Result:
DIN EN ISO 306	<b>dimensional stability under heat</b> Vicat-softening temperature VST/B 50	°C	80 ± 2
DIN EN ISO 179-1 / 1eA / 1eC / 1fC	<b>double-v impact strength a<sub>v</sub></b> (RAL-toughness) Charpy / test bar according to RAL	kJ/m <sup>2</sup> at + 23° C	<b>Ø ≥ 40</b> no value below 20
DIN EN ISO 178 / 527-1 and 527-2	<b>flexural modulus E<sub>f</sub> / tensile modulus E<sub>t</sub></b>	N/mm <sup>2</sup>	2800
DIN EN ISO 182-2 / DIN 53 381-1	<b>stability time t<sub>St</sub></b> pH-measurement methods, oil bath / conductivity measurement methods	minutes at + 200° C	40 ± 6

#### General characteristics of uPVC

according to standard(s)	Description:	Unit:	Result:
DIN 53752 Leitz-dilatometer	<b>coefficient of linear expansion</b> from - 30° to + 50° C	1/K	7 x 10 <sup>-5</sup>
DIN 52612-1/-2/-3 guarded hot plate method	<b>thermal conductivity λ</b> (Lambda)	W/mK	0.16
DIN 4102-1	<b>fire performance uPVC</b> flat profiles	-	B1
DIN 4102-1	<b>fire performance uPVC</b> hollow chamber profiles	-	B2
DIN EN 13501-1	<b>fire performance uPVC</b>	-	E

May be subject to change  
and errors excepted!

scale: ~  
01\_A\_01\_IDEAL\*

General Information  
Material Properties

## 1. Construction

### 1.1. Profile Design

The characteristic feature of the **aluplast** centre profile system **IDEAL 8000** with a profile depth of 85mm is the construction of all standard profiles as 5-6-chamber systems and the especially designed sash and transom profiles for bonding of pane in the rebates (bonding inside).

The multiple inner and outer hollow chambers guarantee an optimum of thermal insulation. Additionally, the outer hollow chamber allows for a concealed drainage and ventilation of the rebate.

The big middle chambers are designed to receive the structurally required reinforcement profiles.

**energeto® 8000**: For the most part, profiles designed for bonding of pane (bonding inside) and/or glass fibre reinforcement (powerdur inside) do not require additional reinforcement and therefore allow for a slender visible frame/sash width.

### 1.2. Gasket Arrangement

Save for a few exceptions, the main profiles are available with gaskets inserted in factory. The centre gasket is located in the sash to avoid the risk of mechanical damage (see also paragraph 5. Gaskets).

The sash`s inner backstop gasket optimises thermal and acoustic insulation values and eliminates condensation in the hardware.

Main profiles with TPE- backstop-, centre and glazing gaskets inserted in factory can be welded.

Optionally available (repair-) gaskets are to be inserted circumferentially in one plane and without gap into main profiles without factory-inserted backstop/centre/glazing gaskets.

## 2. System Range

Design: Classic-line, Soft-line and Round-line  
(Latest product range according to plan of profile IDEAL 8000)

- Frames
- Sashes (recessed, semi-recessed)
- Side entrance door sashes
- False mullion profiles
- Mullions/Transoms

### **energeto® 8000**

- Fibre-reinforced frames (powerdur inside)
- Sashes (recessed) for bonding of pane (bonding inside), fibre-reinforced (powerdur inside)
- Sashes (recessed, semi-recessed) for bonding of pane (bonding inside)

### **aluskin (aluminium shells)**

(Glazing beads available as Classic-line, Soft-line, Round-line and Historik-line)

### 3. Ways of Opening

The **aluplast** 5-6-chamber centre gasket profile system **IDEAL 8000** offers the adequate way of opening for each application and purpose, e.g. for renovations and new buildings both in the residential housing sector and in the administrative and industrial building sector. Furthermore, **IDEAL 8000** can be combined with various aluplast systems.

- Single opening windows and doors
- Tilt-and-turn windows and doors
- Bottom- and top-hung windows
- French casement windows and doors
- Multi-sash windows and doors with mullion and transom
- Window walls
- Oblique and arched windows
- Fixed glazing

### 4. Hardware

All sash and false mullion profiles are equipped with a euro-hardware groove of 16mm and a locking axle of 13mm.

All hardware types with RAL-quality label from diverse manufacturers are applicable.

Locking units are system-related and available at hardware retailers.

For aluminium elements only stainless steel screws – minimum quality V2A – may be applied.

### 5. Gaskets

**aluplast**-profiles are, according to price list, also available **with** gaskets integrated in factory.

TPE: can be welded, thermoplastic elastomer according to RAL-GZ 716/1 paragraph II			
<b>Main profiles: Carrier colour in</b>	white		brown
	similar to RAL 9016		similar to RAL 8019
<b>Lamination</b>	not laminated	laminated on one side	laminated on both sides
<b>Gaskets integrated in factory:</b>	papyrus white	black	

For main profiles **without** gaskets inserted in factory, (repair-) glazing gaskets, (repair-) backstop gaskets and (repair-) centre gaskets are optionally available in papyrus white or black. These gaskets are made of weathering and aging resistant EPDM-material.

EPDM: cannot be welded, moulding compound according to DIN 7863

Gaskets are to be inserted circumferentially and butt joined in the upper cross-piece of the frame or sash. Cutting the gasket in the mitre corner is not necessary.

## 6. Glazing

All standard single-layer glazing, insulating glasses and door infills can be installed.

Glazing is installed with pre-assembled sealing profiles (dry glazing).

Applicable glazing thickness:	Standard:	20 to 51mm
	Extended rebate:	28 to 59mm

## 7. Reinforcements and Aluminium Profiles

Depending on window dimensions and structural requirements, cold-rolled, galvanised steel profiles have to be inserted into frames, sashes, and mullion or transom for reinforcement in case that the profiles are provided with a reinforcement chamber or another reinforcement option.

Material:	Hollow profiles	Band EN 10142 DX51D+Z275 NA-C
	Open profiles	Band EN 10142 DX51D+Z275 NA-C

Corrosion protection zinc coating according to DIN EN 10326  
 Minimum zinc coating for interior reinforcement: 150g/m<sup>2</sup>  
 Minimum zinc coating for exterior reinforcement: 275g/m<sup>2</sup>

**Aluminium profiles:** AlMgSi

For aluminium elements only stainless steel screws – minimum quality V2A – may be applied.

**Note:** Some sashes for bonding of pane and some frames of the **IDEAL 8000** serial **do not** require reinforcement since load is transferred over the bonding edge of the glazing in the sash. Moreover, some sashes and frames are additionally fibre-reinforced.

## 8. Lamination and Colours

Profiles are partly available with decor lamination. For further information about the available colour range, please see the current price or lamination list. The base profile colour is white, similar to RAL 9016 or brown similar to RAL 8019.

## 9. Care and Maintenance

uPVC-window profiles can be cleaned easily using commercially-available mild cleansing agents. Solvents or abrasive cleansing agents must not be used.

Hardware must be lubricated according to manufacturers` specifications.

See **chapters 10 R Care, 10 S Maintenance, 10 T Ventilation** for further information about care and maintenance and cleansing agents recommended by **aluplast**.

## 10. Window Material

See **chapter 01 A Material Properties**.



## Product Data Specifications Standard uPVC window aluplast IDEAL 8000®

**Material:** Heat-absorbing insulation glass ( $U_g$  as per table)  
uPVC (ISO 1163 - PVC-U, EDLP, 082-50-T28) ( $U_f$  as per table)  
multi-chamber profiles with steel reinforcement

**Properties:** Air permeability: up to class: 4 (DIN EN 12207)  
Driving rain resistance: up to class: 9A (DIN EN 12208)  
Resistance to wind load: up to class: C5 (DIN EN 12210)  
Sound insulation (glass thickness 2x 4mm or 3x 4mm) corresponds to insulating glass unit  $R_w = 30$  dB; according to EN 14351-1 results:  
 $R_{w,P} = 33$  dB ( $R_{w,R} = R_{w,P} - 2$  dB)  
P: test value; R: calculated value

**Characteristics:** By installing a sound insulation glass (according to the corresponding aluplast - certification report) a  $R_{w,P}$  of 46 dB ( $R_{w,R} = R_{w,P} - 2$  dB) can be achieved.  
P: test value; R: calculation value

**Thermal insulation:**  $U_w$  -value window (DIN EN ISO 10077-1) as per table.

**Reference size:** 1.23m x 1.48m<sup>1)</sup>

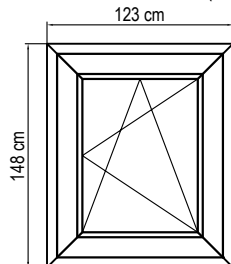

scale: 1:50

**System provider:** aluplast GmbH, Auf der Breit 2, D-76227 Karlsruhe

- Notes:**
- Windows with a thermal transfer coefficient of glazing  $U_g < 1.9$  W/m<sup>2</sup>K may be indicated at any time with the standard value 1.23m x 1.48m (DIN EN 14351-1: table E.1, footnote "d").
  - $U_w$  -values < 1.0 W/m<sup>2</sup>K are indicated with 2 decimal places in accordance with DIN EN ISO 10077.
  - PHT:  $U_f$  -value  $\leq 1.2$  W/m<sup>2</sup>K and  $U_w$  -value  $\leq 0.80$  W/m<sup>2</sup>K: window = highly heat insulated / Passive-House-suitable. (If available: see identification mark "PHT" in table)
  - Additional measures allow for a higher glass thickness.

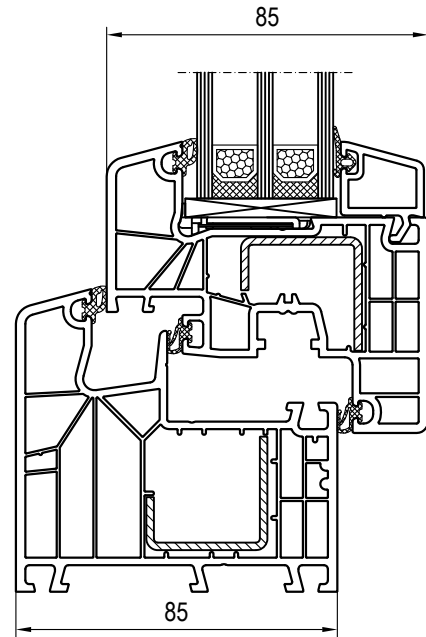

Underlying profile combination for  $U_f$   
scale: 1:2

$U_f$ Frame	$U_g$ Glazing	$U_w$ Window			
		insulating glass edge sealing standard (e.g. aluminium)	insulating glass edge sealing Warm Edge	insulating glass edge sealing Warm Edge	insulating glass edge sealing Warm Edge
on basis of underlying profile combinations and features (material)	with standard gasket without glazing rebate extension	$\Psi$ (Psi) 0.07 [W/mK]	$\Psi$ (Psi) 0.04 [W/mK]	$\Psi$ (Psi) 0.032 [W/mK]	$\Psi$ (Psi) 0.032 [W/mK]
[W/m <sup>2</sup> K]	DIN EN 673 $\Delta T$ (15°C) [W/m <sup>2</sup> K]	DIN EN ISO 10077-1 -> CE-identification mark [W/m <sup>2</sup> K]	DIN EN ISO 10077-1 -> CE-identification mark [W/m <sup>2</sup> K]	DIN EN ISO 10077-1 -> CE-identification mark [W/m <sup>2</sup> K]	DIN EN ISO 10077-1 -> CE-identification mark [W/m <sup>2</sup> K]
1.0	20-51mm <sup>4)</sup>	2) 3) 1.4 (1.44) ○	2) 3) 1.4 (1.37) ○	2) 3) 1.3 (1.35) ○	2) 3) 1.3 (1.28) ○
		1.3 (1.37) ○	1.2 (1.23) ○	1.2 (1.21) ○	1.1 (1.15) ○
		1.2 (1.31) ○	1.1 (1.10) ○	1.1 (1.08) ○	1.0 (1.01) ○
		1.1 (1.24) ○	1.0 (1.03) ○	0.94 ○	0.88 ○
		1.0 (1.17) ○	0.96 ○	0.90 ○	0.81 ○
		0.9 (1.10) ○	0.83 ○	0.76 ○	0.74 ○
		0.8 (1.04) ○	PHT 0.76 ○	PHT 0.74 ○	PHT 0.67 ○
		0.7 0.97 ○	PHT 0.69 ○		
		0.6 0.90 ○			
		0.5 0.83 ○			

○ The  $U_w$  -value Window on basis of  $U_f$  -value Frame and the chosen  $U_g$  -value Glazing can be checked in the table.

May be subject to change and errors excepted!

scale: ~  
01\_E\_01\_8\*

General Information  
Product Data Specifications

## Product Data Specifications Standard uPVC window aluplast IDEAL 8000®

**Material:** Heat-absorbing insulation glass ( $U_g$  as per table)  
uPVC (ISO 1163 - PVC-U, EDLP, 082-50-T28) ( $U_f$  as per table)  
multi-chamber profiles with steel reinforcement,  
sash for bonding of pane (bonding inside)

**Properties:** Air permeability: up to class: 4 (DIN EN 12207)  
Driving rain resistance: up to class: 9A (DIN EN 12208)  
Resistance to wind load: up to class: C5 (DIN EN 12210)  
Sound insulation (glass thickness 2x 4mm or 3x 4mm) corresponds  
to insulating glass unit  $R_{w,R} = 30$  dB; according to EN 14351-1 results:  
 $R_{w,P} = 33$  dB ( $R_{w,R} = R_{w,P} - 2$  dB)  
P: test value; R: calculated value

**Characteristics:** By installing a sound insulation glass (according to the  
corresponding aluplast - certification report) a  
 $R_{w,P}$  of 46 dB ( $R_{w,R} = R_{w,P} - 2$  dB) can be achieved.  
P: test value; R: calculation value

**Thermal insulation:**  $U_w$  -value window (DIN EN ISO 10077-1) as per table.

**Reference size:** 1.23m x 1.48m<sup>1)</sup>

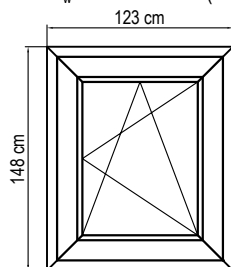

scale: 1:50

**System provider:** aluplast GmbH, Auf der Breit 2, D-76227 Karlsruhe

- Notes:**
- Windows with a thermal transfer coefficient of glazing  $U_g < 1.9$  W/m<sup>2</sup>K may be indicated at any time with the standard value 1.23m x 1.48m (DIN EN 14351-1: table E.1, footnote "d").
  - $U_w$  -values < 1.0 W/m<sup>2</sup>K are indicated with 2 decimal places in accordance with DIN EN ISO 10077.
  - PHT:  $U_f$  -value  $\leq 1.2$  W/m<sup>2</sup>K and  $U_w$  -value  $\leq 0.80$  W/m<sup>2</sup>K: window = highly heat insulated / Passive-House-suitable. (If available: see identification mark "PHT" in table)
  - Additional measures allow for a higher glass thickness.

6 chambers  
recessed (fv.)  
Round-line  
bonding of pane

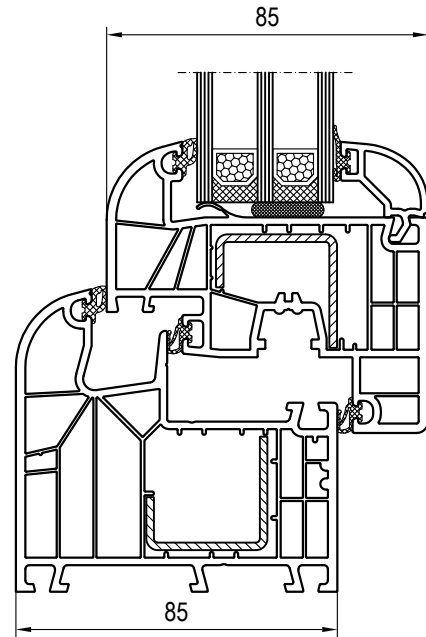

Underlying profile combination for  $U_f$   
scale: 1:2

$U_f$ Frame	$U_g$ Glazing	$U_w$ Window		
		insulating glass edge sealing standard (e.g. aluminium) $\Psi$ (Psi) 0.07 [W/mK]	insulating glass edge sealing Warm Edge $\Psi$ (Psi) 0.04 [W/mK]	insulating glass edge sealing Warm Edge $\Psi$ (Psi) 0.032 [W/mK]
on basis of underlying profile combinations and features (material)	with standard gasket without glazing rebate extension 20-51mm <sup>4)</sup>	insulating glass edge sealing standard (e.g. aluminium) $\Psi$ (Psi) 0.07 [W/mK]	insulating glass edge sealing Warm Edge $\Psi$ (Psi) 0.04 [W/mK]	insulating glass edge sealing Warm Edge $\Psi$ (Psi) 0.032 [W/mK]
[W/m <sup>2</sup> K]	DIN EN 673 $\Delta T$ (15°C) [W/m <sup>2</sup> K]	DIN EN ISO 10077-1 -> CE-identification mark 2) 3) [W/m <sup>2</sup> K]	DIN EN ISO 10077-1 -> CE-identification mark 2) 3) [W/m <sup>2</sup> K]	DIN EN ISO 10077-1 -> CE-identification mark 2) 3) [W/m <sup>2</sup> K]
1.0	1.4	1.4 (1.44) ○	1.4 (1.37) ○	1.3 (1.35) ○
	1.3	1.4 (1.37) ○	1.3 (1.30) ○	1.3 (1.28) ○
	1.2	1.3 (1.31) ○	1.2 (1.23) ○	1.2 (1.21) ○
	1.1	1.2 (1.24) ○	1.2 (1.17) ○	1.1 (1.15) ○
	1.0	1.2 (1.17) ○	1.1 (1.10) ○	1.1 (1.08) ○
	0.9	1.1 (1.10) ○	1.0 (1.03) ○	1.0 (1.01) ○
	0.8	1.0 (1.04) ○	0.96 ○	0.94 ○
	0.7	0.97 ○	0.90 ○	0.88 ○
	0.6	0.90 ○	0.83 ○	0.81 ○
	0.5	0.83 ○	PHT 0.76 ○	PHT 0.74 ○
0.4	PHT 0.77 ○	PHT 0.69 ○	PHT 0.67 ○	

○ The  $U_w$  -value Window on basis of  $U_f$  -value Frame and the chosen  $U_g$  -value Glazing can be checked in the table.

May be subject to change  
and errors excepted!

scale: ~  
01\_E\_01\_8\*

General Information  
Product Data Specifications

## Product Data Specifications

Standard uPVC window  
aluplast IDEAL 8000®  
energeto® 8000  
6 chambers  
recessed (fv.)  
Classic-line  
bonding of pane  
fibre-reinforced profiles

**Material:** Heat-absorbing insulation glass ( $U_g$  as per table)  
uPVC (ISO 1163 - PVC-U, EDLP, 082-50-T28) ( $U_f$  as per table)  
multi-chamber profiles without steel reinforcement,  
fibre-reinforced (powerdur inside),  
sash for bonding of pane (bonding inside)

**Properties:** Air permeability: up to class: 4 (DIN EN 12207)  
Driving rain resistance: up to class: 9A (DIN EN 12208)  
Resistance to wind load: up to class: C5 (DIN EN 12210)  
Sound insulation (glass thickness 2x 4mm or 3x 4mm) corresponds  
to insulating glass unit  $R_{w,R} = 30$  dB; according to EN 14351-1 results:  
 $R_{w,P} = 33$  dB ( $R_{w,R} = R_{w,P} - 2$  dB)  
P: test value; R: calculated value

**Characteristics:** By installing a sound insulation glass (according to the  
corresponding aluplast - certification report) a  
 $R_{w,P}$  of 45 dB ( $R_{w,R} = R_{w,P} - 2$  dB) can be achieved.  
P: test value; R: calculation value

**Thermal insulation:**  $U_w$  -value window (DIN EN ISO 10077-1) as per table.

**Reference size:** 1.23m x 1.48m<sup>1)</sup>

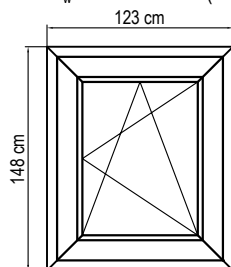

scale: 1:50

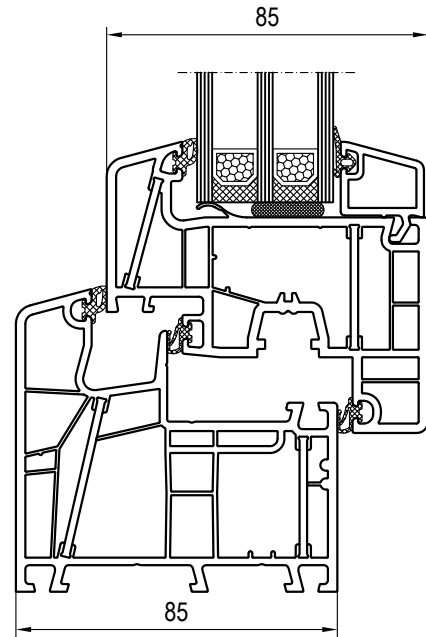

Underlying profile combination for  $U_f$   
scale: 1:2

**System provider:** aluplast GmbH, Auf der Breit 2, D-76227 Karlsruhe

- Notes:**
- Windows with a thermal transfer coefficient of glazing  $U_g < 1.9$  W/m<sup>2</sup>K may be indicated at any time with the standard value 1.23m x 1.48m (DIN EN 14351-1: table E.1, footnote "d").
  - $U_w$  -values < 1.0 W/m<sup>2</sup>K are indicated with 2 decimal places in accordance with DIN EN ISO 10077.
  - PHT:  $U_f$  -value  $\leq 1.2$  W/m<sup>2</sup>K and  $U_w$  -value  $\leq 0.80$  W/m<sup>2</sup>K: window = highly heat insulated / Passive-House-suitable. (If available: see identification mark "PHT" in table)
  - Additional measures allow for a higher glass thickness.

$U_f$ Frame	$U_g$ Glazing	$U_w$ Window		
		insulating glass edge sealing standard (e.g. aluminium)	insulating glass edge sealing Warm Edge	insulating glass edge sealing Warm Edge
on basis of underlying profile combinations and features (material)	with standard gasket without glazing rebate extension	standard (e.g. aluminium)	Warm Edge	Warm Edge
	20-51mm <sup>4)</sup>	$\Psi$ (Psi) 0.07 [W/mK]	$\Psi$ (Psi) 0.04 [W/mK]	$\Psi$ (Psi) 0.032 [W/mK]
[W/m <sup>2</sup> K]	DIN EN 673 $\Delta T$ (15°C) [W/m <sup>2</sup> K]	DIN EN ISO 10077-1 -> CE-identification mark 2) 3) [W/m <sup>2</sup> K]	DIN EN ISO 10077-1 -> CE-identification mark 2) 3) [W/m <sup>2</sup> K]	DIN EN ISO 10077-1 -> CE-identification mark 2) 3) [W/m <sup>2</sup> K]
0.94	1.4	1.4 (1.42) ○	1.3 (1.35) ○	1.3 (1.33) ○
	1.3	1.4 (1.36) ○	1.3 (1.28) ○	1.3 (1.26) ○
	1.2	1.3 (1.29) ○	1.2 (1.21) ○	1.2 (1.19) ○
	1.1	1.2 (1.22) ○	1.1 (1.15) ○	1.1 (1.13) ○
	1.0	1.2 (1.15) ○	1.1 (1.08) ○	1.1 (1.06) ○
	0.9	1.1 (1.08) ○	1.0 (1.01) ○	0.99 ○
	0.8	1.0 (1.02) ○	0.94 ○	0.92 ○
	0.7	0.95 ○	0.88 ○	0.86 ○
	0.6	0.88 ○	0.81 ○	PHT 0.79 ○
	0.5	0.81 ○	PHT 0.77 ○	PHT 0.72 ○
0.4	PHT 0.75 ○	PHT 0.67 ○	PHT 0.65 ○	

○ The  $U_w$  -value Window on basis of  $U_f$  -value Frame and the chosen  $U_g$  -value Glazing can be checked in the table.

May be subject to change and errors excepted!

scale: ~  
01\_E\_01\_8\*

General Information  
Product Data Specifications

**Material:** Heat-absorbing insulation glass ( $U_g$  as per table)  
uPVC (ISO 1163 - PVC-U, EDLP, 082-50-T28) ( $U_f$  as per table)  
multi-chamber profiles without steel reinforcement  
fibre-reinforced (powerdur inside), foam-filled (foam inside),  
sash for bonding of pane (bonding inside)

**Properties:** Air permeability: up to class: 4 (DIN EN 12207)  
Driving rain resistance: up to class: 9A (DIN EN 12208)  
Resistance to wind load: up to class: C5 (DIN EN 12210)  
Sound insulation (glass thickness 2x 4mm or 3x 4mm) corresponds to insulating glass unit  $R_{w,R} = 30$  dB; according to EN 14351-1 results:  
 $R_{w,P} = 33$  dB ( $R_{w,R} = R_{w,P} - 2$  dB)  
P: test value; R: calculated value

**Characteristics:** By installing a sound insulation glass (according to the corresponding aluplast - certification report) a  $R_{w,P}$  of 45 dB ( $R_{w,R} = R_{w,P} - 2$  dB) can be achieved.  
P: test value; R: calculation value

**Thermal insulation:**  $U_w$  -value window (DIN EN ISO 10077-1) as per table.

**Reference size:** 1.23m x 1.48m<sup>1)</sup>

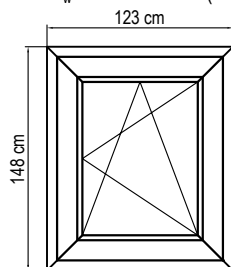

scale: 1:50

**System provider:** aluplast GmbH, Auf der Breit 2, D-76227 Karlsruhe

- Notes:**
- Windows with a thermal transfer coefficient of glazing  $U_g < 1.9$  W/m<sup>2</sup>K may be indicated at any time with the standard value 1.23m x 1.48m (DIN EN 14351-1: table E.1, footnote "d").
  - $U_w$  -values < 1.0 W/m<sup>2</sup>K are indicated with 2 decimal places in accordance with DIN EN ISO 10077.
  - PHT:  $U_f$  -value <= 1.2 W/m<sup>2</sup>K and  $U_w$  -value <= 0.80 W/m<sup>2</sup>K: window = highly heat insulated / Passive-House-suitable. (If available: see identification mark "PHT" in table)
  - Additional measures allow for a higher glass thickness.

## Product Data Specifications

Standard uPVC window  
aluplast IDEAL 8000®  
energeto® 8000  
6-chamber  
recessed (fv.)  
Classic-line  
bonding of pane  
fibre-reinforced profiles  
foam-filled profiles

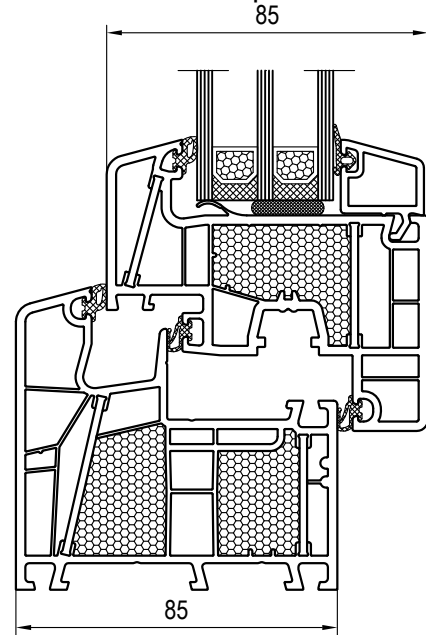

Underlying profile combination for  $U_f$   
scale: 1:2

$U_f$ Frame	$U_g$ Glazing	$U_w$ Window		
		insulating glass edge sealing standard (e.g. aluminium)	insulating glass edge sealing Warm Edge	insulating glass edge sealing Warm Edge
on basis of underlying profile combinations and features (material)	with standard gasket without glazing rebate extension	standard (e.g. aluminium)	Warm Edge	Warm Edge
	20-51mm <sup>4)</sup>	$\Psi$ (Psi) 0.07 [W/mK]	$\Psi$ (Psi) 0.04 [W/mK]	$\Psi$ (Psi) 0.032 [W/mK]
[W/m <sup>2</sup> K]	DIN EN 673 $\Delta T$ (15°C) [W/m <sup>2</sup> K]	DIN EN ISO 10077-1 -> CE-identification mark 2) 3) [W/m <sup>2</sup> K]	DIN EN ISO 10077-1 -> CE-identification mark 2) 3) [W/m <sup>2</sup> K]	DIN EN ISO 10077-1 -> CE-identification mark 2) 3) [W/m <sup>2</sup> K]
0.79	1.4	1.4 (1.37) ○	1.3 (1.30) ○	1.3 (1.28) ○
	1.3	1.3 (1.31) ○	1.2 (1.23) ○	1.2 (1.21) ○
	1.2	1.2 (1.24) ○	1.2 (1.17) ○	1.1 (1.15) ○
	1.1	1.2 (1.17) ○	1.1 (1.10) ○	1.1 (1.08) ○
	1.0	1.1 (1.10) ○	1.0 (1.03) ○	1.0 (1.01) ○
	0.9	1.0 (1.04) ○	0.96 ○	0.94 ○
	0.8	0.97 ○	0.89 ○	0.88 ○
	0.7	0.90 ○	0.83 ○	0.81 ○
	0.6	0.83 ○	PHT 0.76 ○	PHT 0.74 ○
	0.5	PHT 0.77 ○	PHT 0.69 ○	PHT 0.67 ○
0.4	PHT 0.70 ○	PHT 0.62 ○	PHT 0.60 ○	

○ The  $U_w$  -value Window on basis of  $U_f$  -value Frame and the chosen  $U_g$  -value Glazing can be checked in the table.

May be subject to change and errors excepted!

scale: ~  
01\_E\_01\_8\*

General Information  
Product Data Specifications

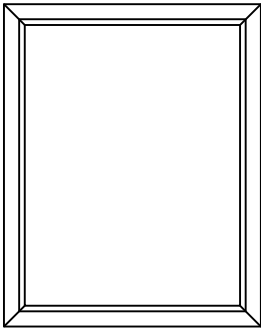

fixed glazing  
in frame

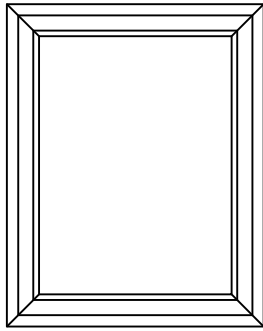

fixed glazing  
in sash

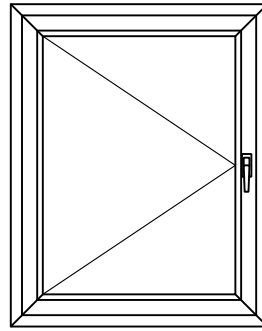

single opening window

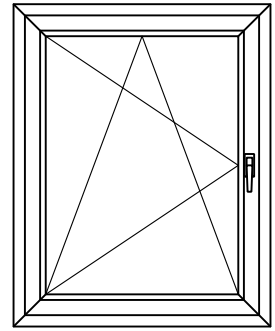

tilt + turn window

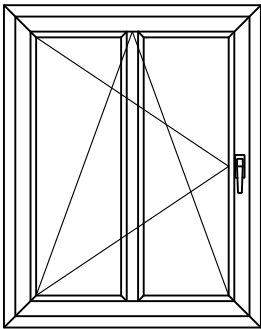

tilt + turn window  
with transom

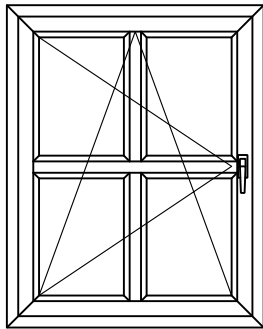

tilt + turn window  
with cross transom

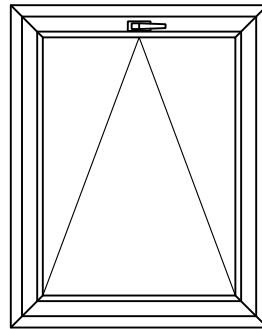

bottom-hung window

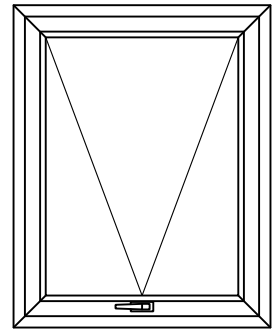

top-hung window

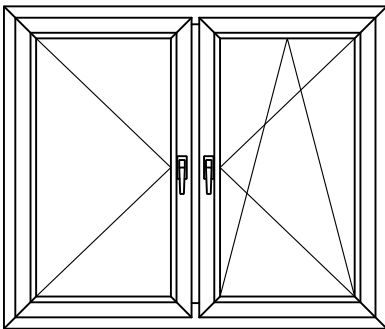

double sash window  
single opening / tilt + turn

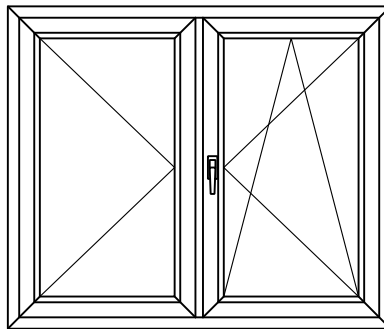

french casement window  
single opening / tilt + turn

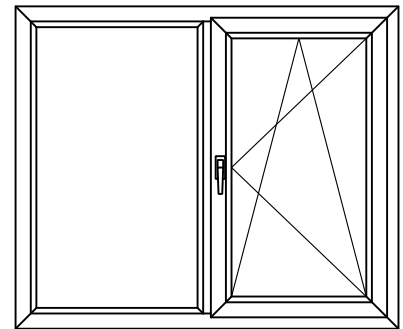

fixed glazing in frame /  
tilt + turn

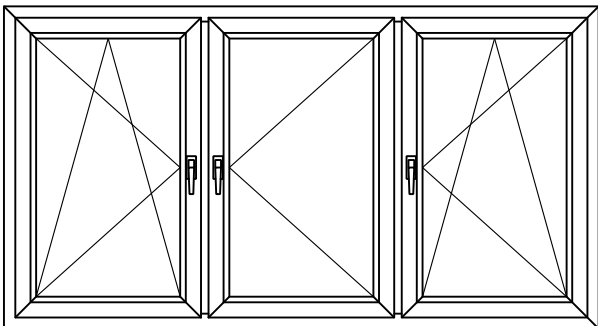

triple sash window  
tilt + turn / single opening / tilt + turn

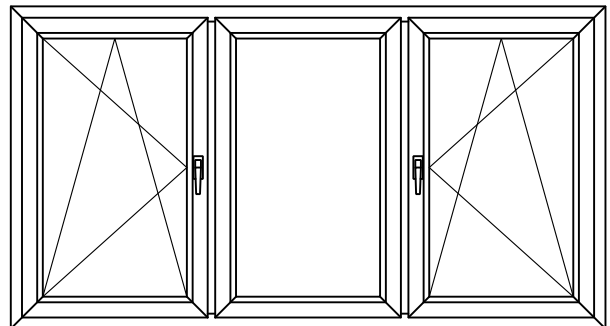

triple sash window  
tilt + turn / fixed glazing in sash / tilt + turn

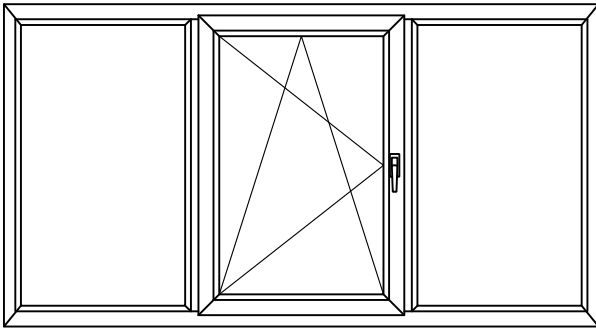

tripartite window  
fixed glazing in frame / tilt + turn / fixed glazing in frame

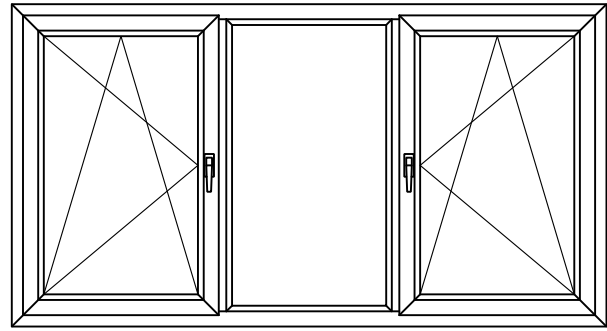

tripartite window  
tilt + turn / fixed glazing in frame / tilt+ turn

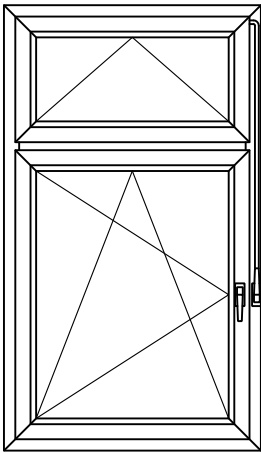

tilt + turn window  
with bottom-hung fanlight

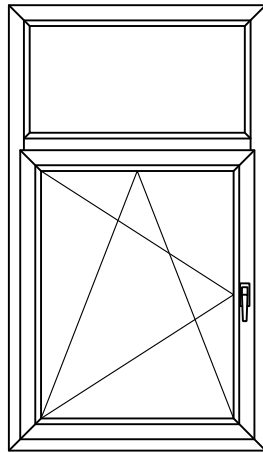

tilt + turn window  
with fixed fanlight

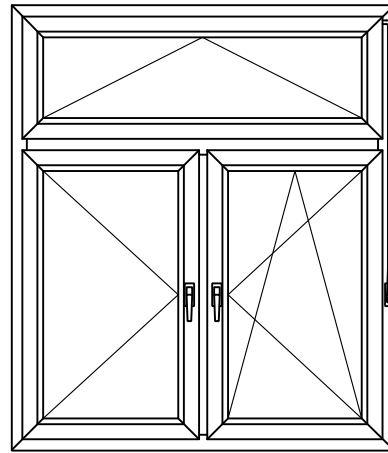

double sash window single opening / tilt + turn  
bottom-hung fanlight

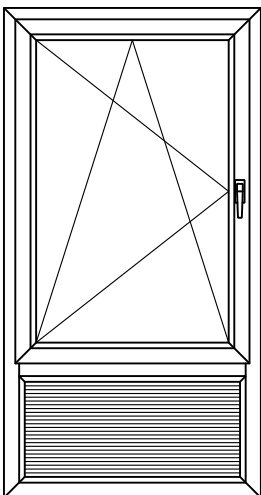

tilt + turn window  
with parapet

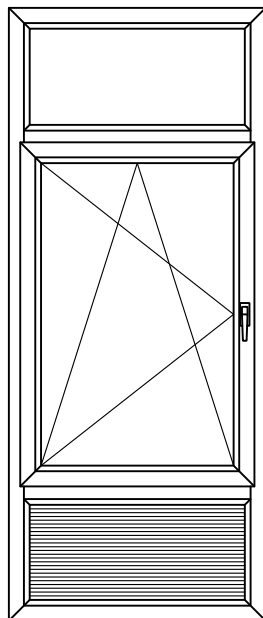

tilt + turn window  
with parapet  
and fixed fanlight

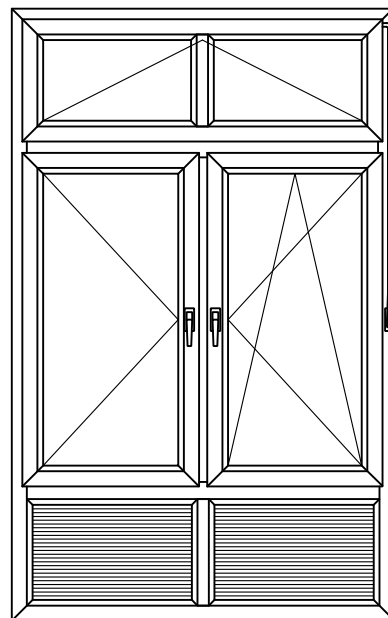

double sash window single opening / tilt + turn  
bottom-hung fanlight with transom  
and parapet with transom

May be subject to change  
and errors excepted!

scale: ~  
01\_G\_01\_IDEAL\*

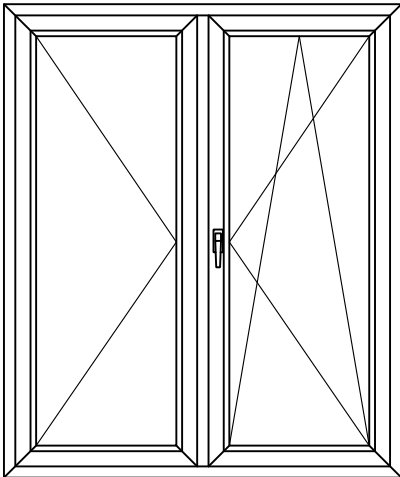

french casement door  
single opening / tilt + turn

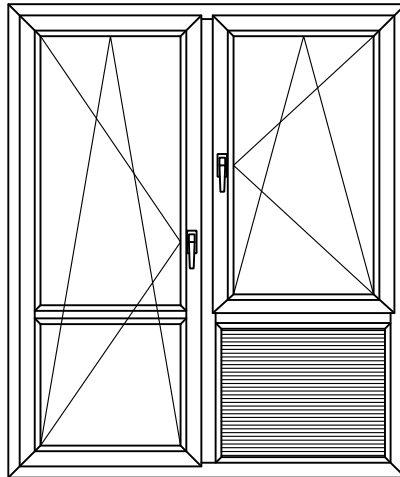

tilt + turn door with transom and  
tilt + turn window with parapet

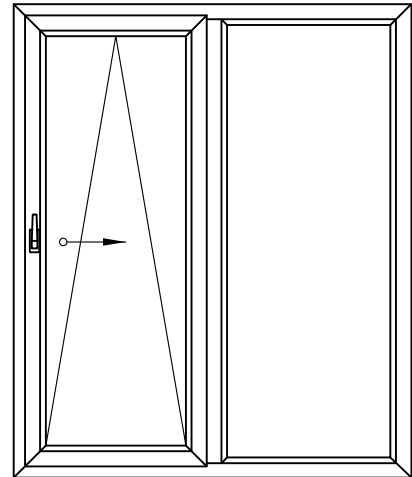

parallel-tilt/ lift + slide door  
with fixed glazing element

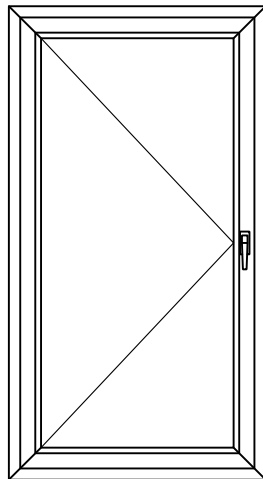

single opening door

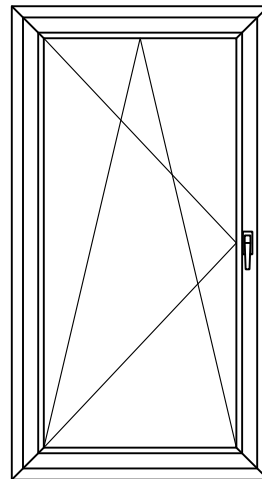

tilt + turn door

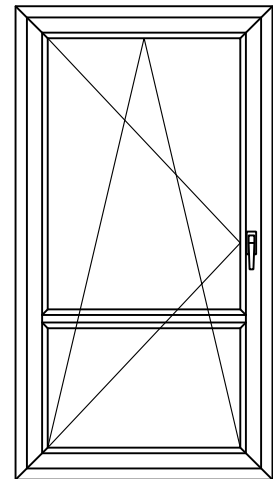

tilt + turn door  
with transom

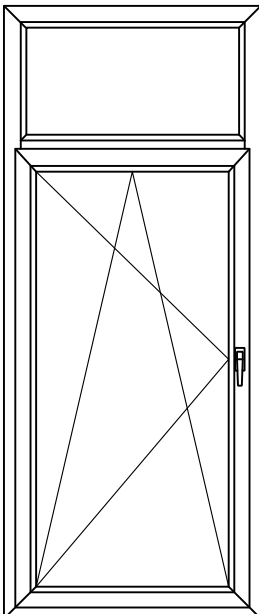

tilt + turn door  
with fanlight with fixed glazing

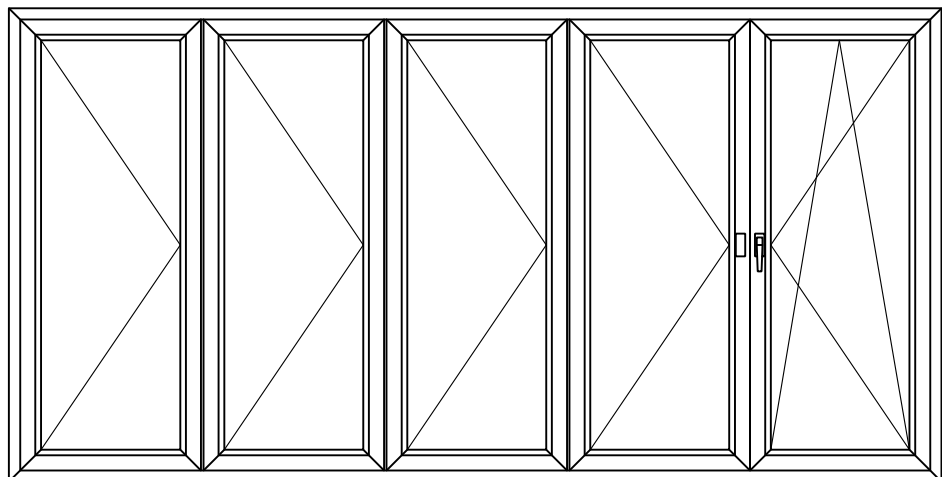

four sash fold + slide door: three folding sashes / one tilt + turn  
(-> hardware-dependent: backstop gasket systems)

May be subject to change  
and errors excepted!

scale: ~  
01\_G\_01\_IDEAL\*

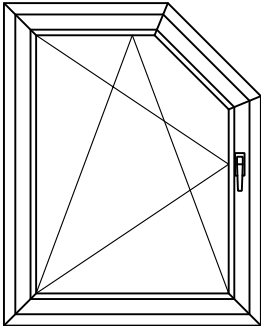

tilt + turn window  
with oblique corner

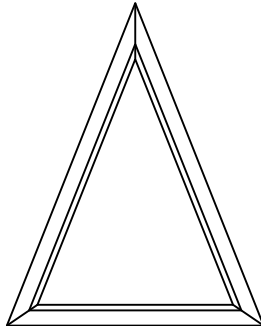

triangular window  
with fixed glazing

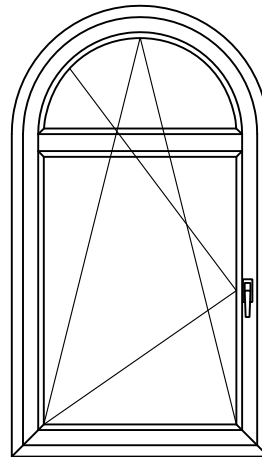

round arched window tilt + turn  
with transom

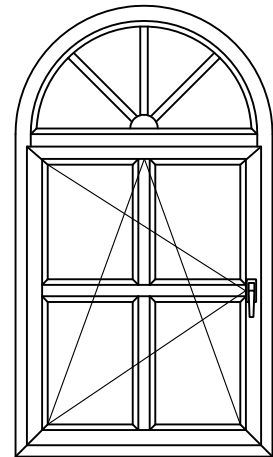

round arched window  
tilt + turn  
with cross transom  
and fixed fanlight

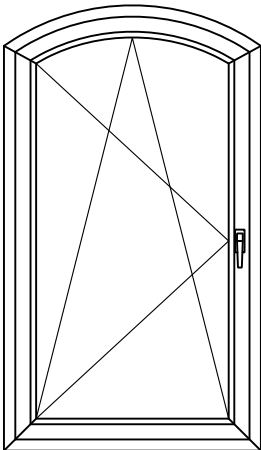

segment bow window  
tilt + turn

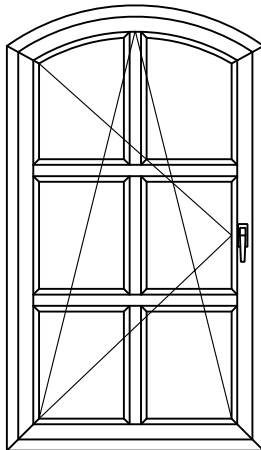

segment bow window  
tilt + turn  
with cross transom

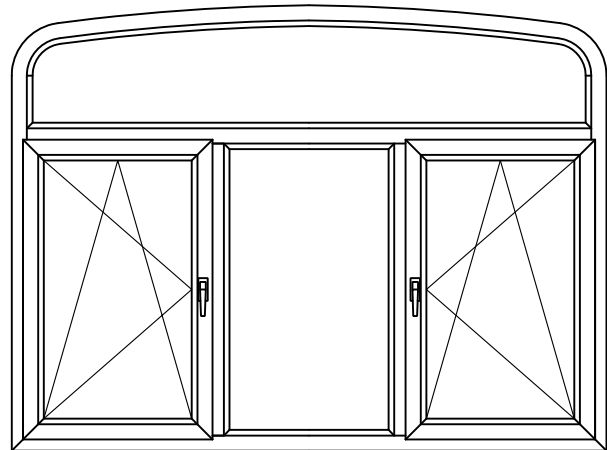

segment bow window with fixed fanlight:  
tilt + turn / fixed glazing in frame / tilt + turn

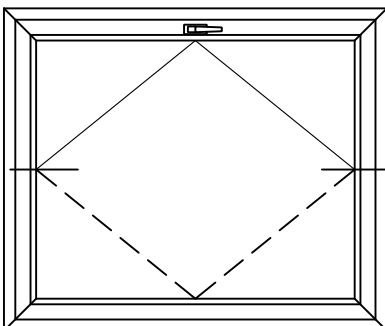

pivot window  
(-> backstop gasket systems)

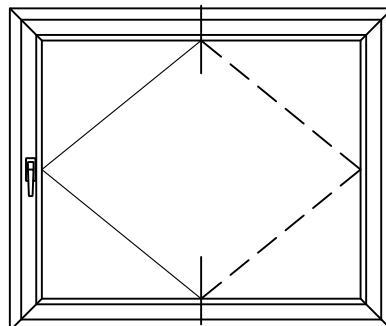

(vertical) pivot window  
(-> backstop gasket systems)

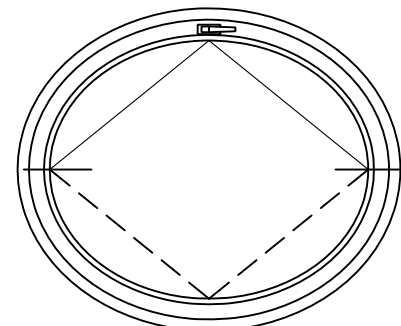

oval pivot window  
(-> backstop gasket systems)

May be subject to change  
and errors excepted!

scale: ~  
01\_G\_01\_IDEAL\*

**General Information**  
**Overview Window Types**



Main Profiles  
Classic-line (CL)

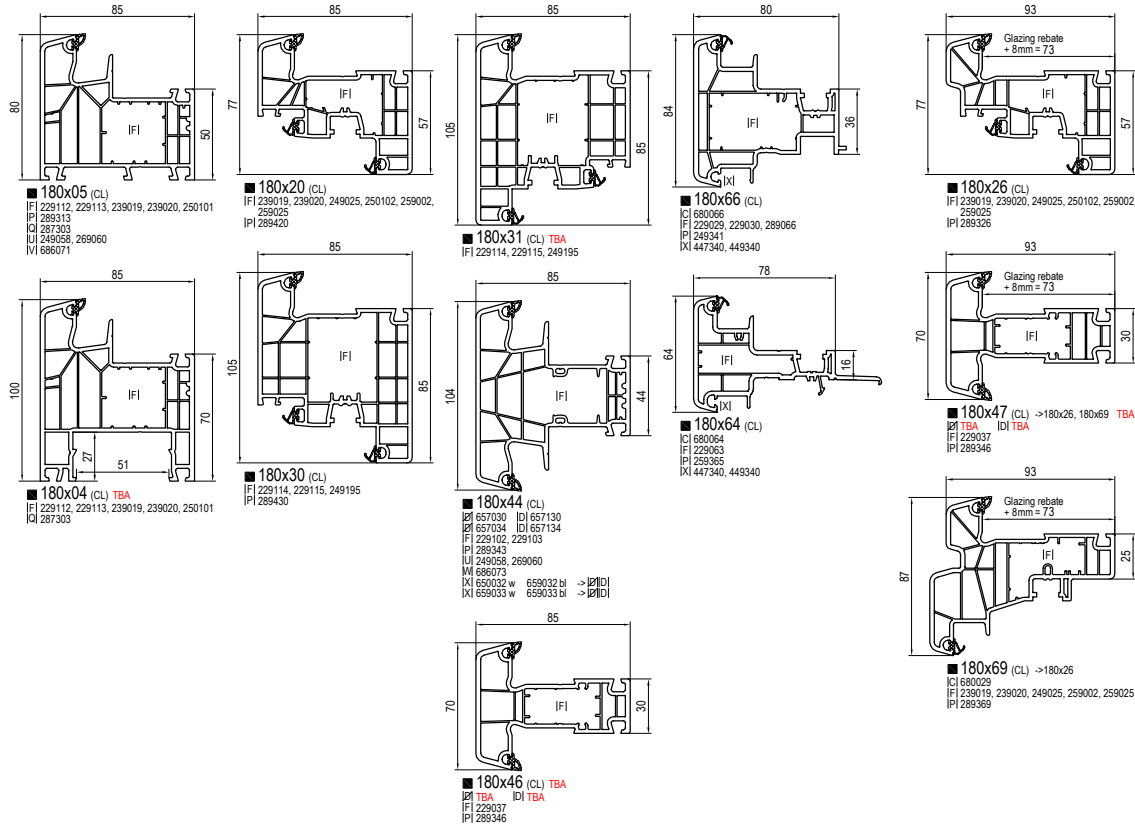

Main Profiles  
Round-line (RL)

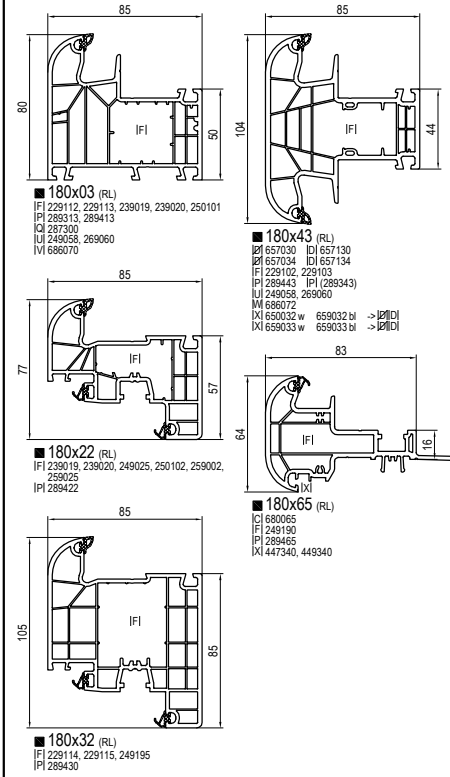

energeto® 8000

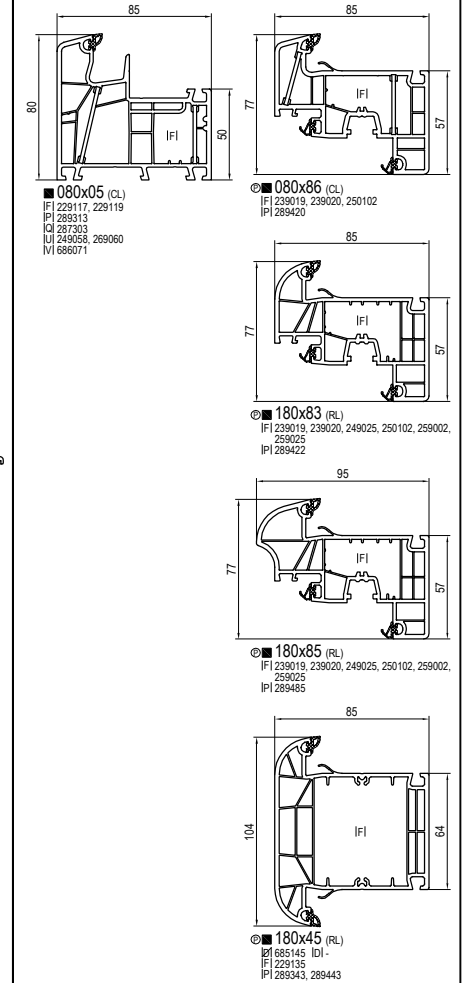

© protected under EP 169254B1

□ without lamination  
 ■ lamination

CI End caps  
 IZ Connector / without sticks  
 ID Connector  
 IPI Connector  
 IFI Reinforcements  
 IJ aluskin Aluminium shells  
 IJ Aluminium threshold  
 IV Connection for threshold  
 IJ Mullion coupler  
 IXI Gaskets

-> for

(CL) Classic-line  
 (SL) Soft-line  
 (RL) Round-line  
 (CH) Schweiz

bi black  
 w white  
 pw papyrus-white  
 gr grey  
 br brown  
 red red  
 ye yellow

TBA in preperation  
 (new or modified)

# ADDITIONAL PROFILES

aluplast GmbH | uPVC window profile systems  
 Auf der Brühl 2 | D-76227 Karlsruhe  
 Tel. +49 (721) 47171-0 | Fax: 999  
 info@aluplast.de | www.aluplast.de



# ADDITIONAL PROFILES 1

## Extension / Coupling profile

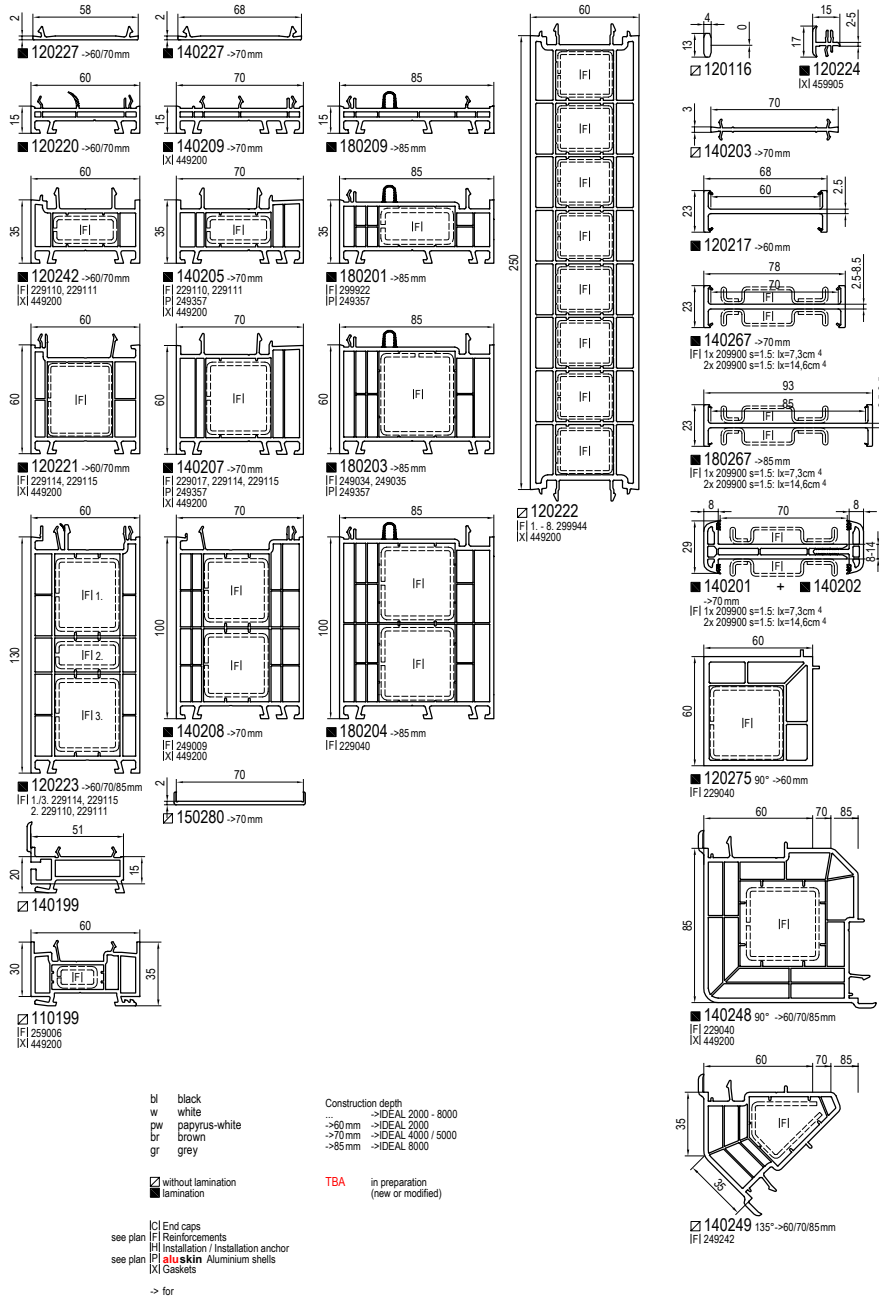

## Structural profiles

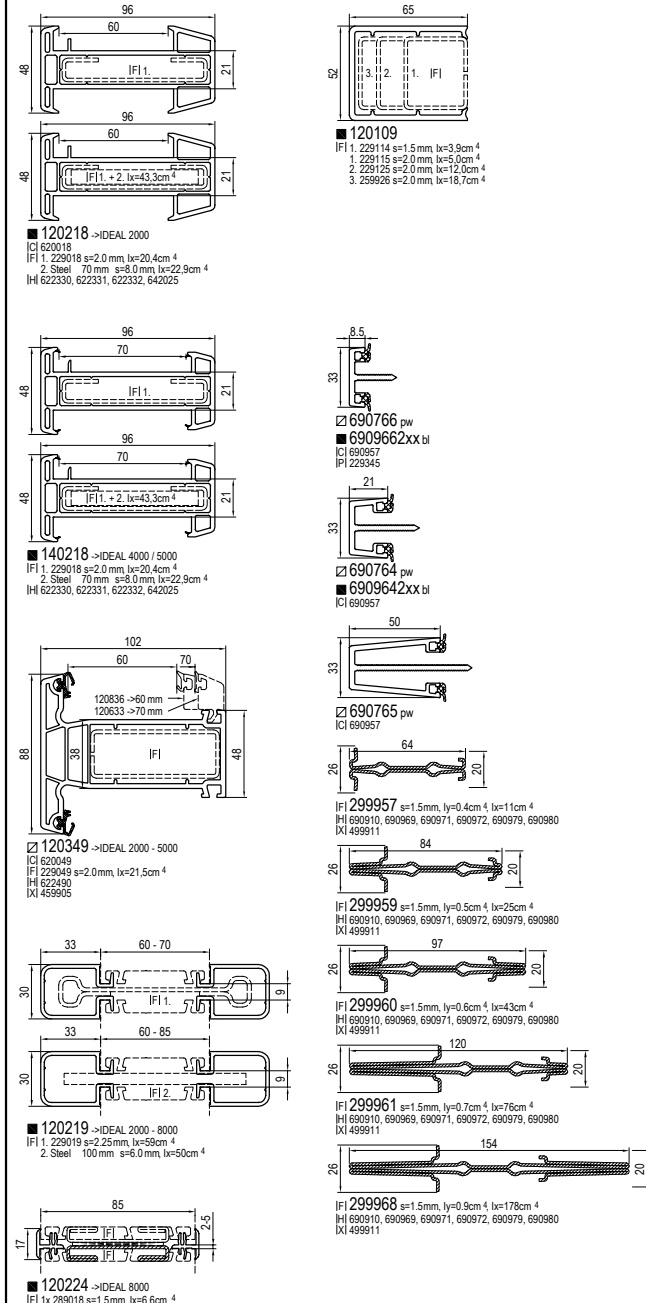

## Accessories

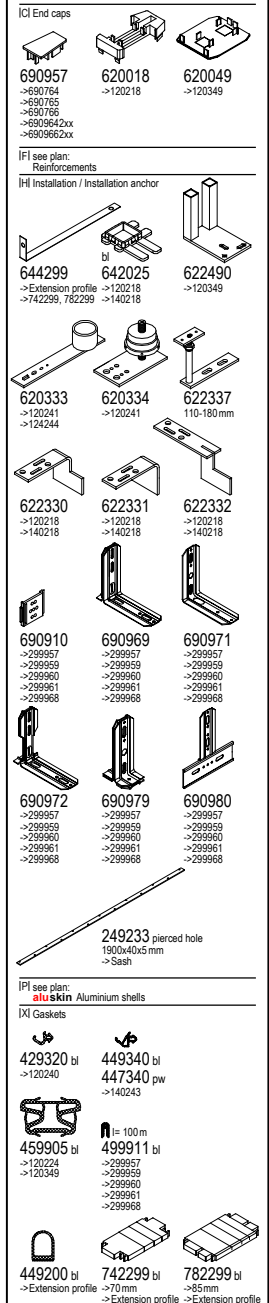

aluplast GmbH | uPVC window profile systems  
Auf der Braut 2 | D-76227 Karlsruhe  
Tel. +49 (721) 47171-0 | Fax: 959  
info@aluplast.de | www.aluplast.de



Additional Profiles

Grid of technical drawings for various window profiles including 120238, 120206, 120208, 120209, 120210, 120115, 120114, 140289, 140288, 140287, 120288, 120287, 120286, 120285, 120121, 120120, 120237, 120236, 120193, 120194, 120195, 120270, 120196, 140197, 120113, 120112, 140107, 120101, 140108, 120100, 150203, 160376 bl, 160377 pw, 160378 bl, 160379 pw, 140373 bl, 140374 pw, 140473 pw, 140474 pw, 160476 pw, 160477 pw, 160478 pw, 120117, 120250, 120256, 120257, 120258, 120259, 120260, 120291, 120292, 120293, 120294, 120295, 120296, 190213, 140275, 190219, 120272, 140276, 120230, 120252, 120202, 150202, 050x96, 120249, 190433 bl, 190430 bl, 190435 bl, 190433 bl, 190435 bl, 500502, 500504.

May be subject to change and errors excepted! Laminated profiles and profiles with gasket: see price list!

Copyright © aluplast GmbH | All rights reserved | Alle Rechte vorbehalten

Accessories

Grid of technical drawings for window accessories including: AI Spacer (660911, 669922, 660916, 669919, 669920, 669900, 669906, 669907, 669912, 669911, 669910, 669908, 669911, 669902, 669903, 669936, 669937, 669938, 669942, 669943, 669944), BI Inlet funnel (620042, 620044, 620038, 500508), ICI End caps (650902, 600220, 650921, 690030, 690035, 620032, 500511), FI/PI see plan: Reinforcements (652923, 659923, 659918, 610004, 690922, 500770, 500510), HI Installation / Installation anchor (642025, 622337, 620198), KI Drain slot caps / Drainage profile (620010, 620013, 620012), MI Panels (uPVC / Sandwich) (620014, 690923, 620320, 620321), RI Aluminium roller shutter guides (429334, 427334, 429335), IYI Gaskets (429334, 427334, 429335), IYI Brush seals (459930, 459932), 420250 w, 421250 br, 449340 bl, 447340 pw, 449200 bl, 500502, 500504, 500506, 500507, 500509, 500510, 500511, 500539, 500538, 500539).

File name: 'Zusatzprofile 2' Issue: 2011-05 Language: English (GB) english

a	Profile serial	c <sup>3)</sup>	d															
			28-29mm	30-31mm	32-33mm	34-35mm	36-37mm	38-39mm	40-41mm	42-43mm	44-45mm	46-47mm	48-49mm	50-51mm	52-53mm	54-55mm	56-57mm	58-59mm
73mm	IDEAL 8000 + 8mm/180250	4mm	28-29mm	30-31mm	32-33mm	34-35mm	36-37mm	38-39mm	40-41mm	42-43mm	44-45mm	46-47mm	48-49mm	50-51mm	52-53mm	54-55mm	56-57mm	58-59mm
65mm	IDEAL 8000, Nord-line Frame	4mm	20-21mm	22-23mm	24-25mm	26-27mm	28-29mm	30-31mm	32-33mm	34-35mm	36-37mm	38-39mm	40-41mm	42-43mm	44-45mm	46-47mm	48-49mm	50-51mm
63mm	IDEAL 5000 + 8mm/180250	4mm	-	-	22-23mm	24-25mm	26-27mm	28-29mm	30-31mm	32-33mm	34-35mm	36-37mm	38-39mm	40-41mm	42-43mm	44-45mm	46-47mm	48-49mm
55mm	IDEAL 4000, IDEAL 5000, HST 70mm <sup>4)</sup> Nord-line Sash	4mm	10-11mm	12-13mm	14-15mm	16-17mm	18-19mm	20-21mm	22-23mm	24-25mm	26-27mm	28-29mm	30-31mm	32-33mm	34-35mm	36-37mm	38-39mm	40-41mm
47mm	IDEAL 2000, multi-sliding <sup>5)</sup>	3mm	-	4-5mm	6-7mm	8-9mm	10-11mm	12-13mm	14-15mm	16-17mm	18-19mm	20-21mm	22-23mm	24-25mm	26-27mm	28-29mm	30-31mm	32-33mm
32mm	duo-rail <sup>5)</sup>	3mm	-	-	-	-	-	-	-	-	4-5mm	6-7mm	8-9mm	10-11mm	12-13mm	14-15mm	16-17mm	18-19mm

**b**

Choose glazing bead  
**b = a - c - d - 1**

**a** = Glazing rebate  
**b** = Glazing bead + gaskets\*  
**c** = Repair gaskets\*  
**d** = Glazing thickness  
**1** = 1mm protrusion

	40mm		38mm		36mm		34mm		32mm		30mm		28mm		26mm		24mm		22mm		20mm		18mm		16mm		14mm		12mm		10mm		
	Gasket																																
h = 20 mm <sup>1)</sup>	black	120740	120840	120640	120639	120838	120638	120736	120836	120636	120734	120834	140853	120633	120832	120632	140631																
	papyrus-white	120770	120870	120670	120669	120868	120668	120766	120866	120666	120764	120864	140883	120663	120862	120662	140661																
h = 30 mm <sup>2)</sup>	black	-	-	-	-	-	-	-	-	-	-	-	-	-	-	-	-	-	-	-	-	-	-	-	-	-	-	-	-	-	-	-	
	papyrus-white	-	-	-	-	-	-	-	-	-	-	-	-	-	-	-	-	-	-	-	-	-	-	-	-	-	-	-	-	-	-	-	

- \* compressed gasket
- <sup>1)</sup> for backstop gasket systems
- <sup>2)</sup> for centre gasket systems
- <sup>3)</sup> or profile with gasket
- <sup>4)</sup> Sash Lift-and-slide door
- <sup>5)</sup> Sash Sliding Window

- bl black - RAL 9005
- pw papyrus-white - RAL 9018
- w white

- (CL) Classic-line
- (SL) Soft-line
- (RL) Round-line
- (HL) Historik-line

- (A) aluplast austria

- without lamination
- lamination

- aluskim Aluminium shells

- > for

- TBA in preparation (new or modified)

Repair gaskets

-> Main Profiles

IDEAL 2000, multi-sliding <sup>5)</sup>	Glazing thickness		Option = d		Option = d - 1mm		Option = d - 2mm	
	Standard	Option = d	Standard	Option = d	Standard	Option = d	Standard	Option = d
IDEAL 4000-8000, Nord-line, HST 70 mm <sup>4)</sup>	= d	= d + 1mm	= d	= d + 1mm	= d	= d - 1mm	= d	= d - 1mm
duo-rail <sup>5)</sup>	= d	= d	= d	= d	= d - 1mm	= d - 1mm	= d - 2mm	= d - 2mm

-> Glazing Beads

xxx6xx	xxx8xx	xxx7xx	-> aluskim required							
429310 bl	429311 bl	429312 bl	429921 bl	459922 bl	459925 bl	449980 bl	449002 bl	459923 bl	459951 bl	449986 bl
427310 pw	427311 pw	427312 pw	427921 pw	450925 pw	450925 pw	447980 pw	- pw	- pw	- pw	- pw
			C = 3mm	C = 3mm	C = 3mm	C = 4mm	C = 4mm	C = 5mm	C = 4mm	C = 4mm

Additional Profiles

for centre gasket systems for frame and mullion with glazing beads h = 20mm

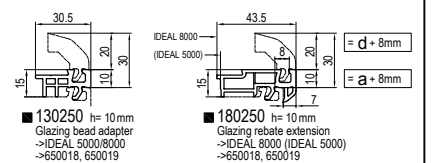

(...) = 180250, 650018 cut

# ACCESSORIES

aluplast GmbH | uPVC window profile systems  
 Auf der Brühl 2 | D-76227 Karlsruhe  
 Tel. +49 (721) 47171-0 | Fax: 999  
 info@aluplast.de | www.aluplast.de



# ACCESSORIES IDEAL 2000 - 8000®

## IDEAL 2000

**AI Spacer**

620301 620305

**CI End caps**

(CL) 620001 →120x63 (RL) 620060 →120x60 (CL) 620002 →120x61 (RL) 620097 →120x97 620029 →120x77

**DI Connector / without sticks**

(MB) 620414 →110x06 (MB) 620415 →110x08 →110x09 →110x09 →120x19 →120x19

**EI Corner connector**

620141 627131 627132 627135 627107 627101 627101 627102 627105 627107

**FI see plan: Reinforcements**

620125 620126 640938 IFI 229125, 229129 IFI 229126, 229131 IFI 229135, 229137

**HI Installation / Installation anchor**

620410

**II Lifter**

620440 620441 640441 624015

**LI Basic ventilation system**

630315 Set

**MI Gaskets**

Standard	Standard	Standard	Standard
429921 bl	459922 bl	459925 bl	459923 bl
427921 pw		450925 pw	
		453925 och	
Standard	Standard	Standard	Standard
429340 bl	429320 bl	429318 bl	429330 bl
420340 pw		427318 pw	420330 w

## IDEAL 4000 / 4000 NL

**AI Spacer**

640301 640311

**CI End caps**

(CL) 640067 →140x67 (RL) 640069 →140x69 (CL) 640065 →140x65 (RL) 620097 →120x97 640082 →140x76 →140x77 →140x82 →140x84

**DI Connector / without sticks**

(NL) 647101 647102 677103 647105 647131 647132 677133 627107 647057

**EI Corner connector**

620125 620126 640031 640032 640038 640938 IFI 229125, 229129 IFI 229126, 229131 IFI 229135, 229137

**FI see plan: Reinforcements**

620410

**II Lifter**

620440 640441 640015

**LI Basic ventilation system**

630315 Set

**MI Gaskets**

Standard	Standard	Standard	Standard
449980 bl	459922 bl	459925 bl	449002 bl
447980 pw		450925 pw	
		453925 och	
Standard	Standard	Standard	Standard
449340 bl	449343 bl	429318 bl	429330 bl
447340 pw	447343 pw	427318 pw	420330 w
			440357 w

## IDEAL 4000 - 8000

**LI Bonding of pane**

640033 red 3mm 640113 red 13mm 640015 w 12mm 640034 ye 4mm 640114 ye 14mm 640019 ye 14mm 645234 bl 4.5mm

## IDEAL 5000 / 8000

**AI Spacer**

640301 640311 650016

**CI End caps**

650018 650019 680016 620301 620305

**DI Connector / without sticks**

(CH) 650029 650065 660066 650066 650090

**EI Corner connector**

680029 680066 680064

**FI see plan: Reinforcements**

680029 680066 680064

**II Lifter**

680065 657030 657034 657130 657134

**LI Basic ventilation system**

630315 Set

**MI Gaskets**

Standard	Standard	Standard	Standard
657035 bl	647101 bl	647102 bl	
657135 bl	647131 bl	647132 bl	
650032 w	650032 bl	650033 w	650033 bl
657030 bl	657034 bl	657130 bl	657134 bl

**LI Bonding of pane**

685145 TBA 650010 650037

## Aluminium threshold / Aluminium step protection

**LI End caps**

646052 gr 626062 gr

**LI Aluminium threshold**

6229059 gr 6229060 gr

**LI Aluminium step protection**

6227300 (CL) 6227303 (CL)

**LI Aluminium threshold**

6227305 (CL)

**LI Aluminium threshold**

6227305 (CL)

**LI Aluminium threshold**

6227305 (CL)

**LI Aluminium threshold**

6227305 (CL)

**LI Aluminium threshold**

6227305 (CL)

**LI Aluminium threshold**

6227305 (CL)

**MI Mullion coupler**

626072

**MI Mullion coupler**

646070 646071 646072 646073 646074 646075

**MI Mullion coupler**

686070 686071 686072 686073 686074

**MI Mullion coupler**

646076 646077

**MI Mullion coupler**

499910 w 156252 gr 440036 w 446091 gr 446092 gr

**MI Mullion coupler**

429340 bl 429340 pw 449340 bl 447340 pw 449343 bl 447343 pw 449343 bl 447343 pw

**MI Mullion coupler**

429340 bl 429340 pw 449340 bl 447340 pw 449343 bl 447343 pw 449343 bl 447343 pw

**MI Mullion coupler**

429340 bl 429340 pw 449340 bl 447340 pw 449343 bl 447343 pw 449343 bl 447343 pw

**MI Mullion coupler**

429340 bl 429340 pw 449340 bl 447340 pw 449343 bl 447343 pw 449343 bl 447343 pw

IP | aluskin Aluminium shells

<p><b>Frame</b></p> <p>SL 106mm AU 236mm</p> <p>IGI 620020</p> <p>249312 (CL) 2</p> <p>-&gt;04x07 (CL) -&gt;140x02 (CL) -&gt;140x07 (CL) -&gt;150x02 (CL) -&gt;150x02 (CL) -&gt;150x11 (CL)</p>	<p><b>IDEAL 4000 / 5000</b></p> <p>SL 103mm AU 255mm</p> <p>IGI 620020</p> <p>249313 (CL) 2</p> <p>-&gt;140x03 (CL) -&gt;050x03 (CL) -&gt;150x03 (CL)</p>	<p><b>Frame</b></p> <p>SL 135mm AU 251mm</p> <p>IGI 620020</p> <p>249314 (CL) 2</p> <p>-&gt;150x04 (CL)</p>	<p><b>IDEAL 5000</b></p> <p>48.5</p> <p>259310 (CL) 2</p> <p>-&gt;150x10 (CL) -&gt;150x12 (CL)</p>	<p><b>Frame</b></p> <p>SL 121mm AU 253mm</p> <p>IGI 620020</p> <p>289313 (CL) 2</p> <p>-&gt;080x05 (CL) -&gt;180x05 (CL) -&gt;180x03 (RL)</p>	<p><b>IDEAL 8000</b></p> <p>SL 116mm AU 242mm</p> <p>IGI 620020</p> <p>289413 (RL) 1</p> <p>-&gt;180x03 (RL)</p>	<p><b>Additional Profiles</b></p> <p>IGI 620020</p> <p>249357 (CL)</p> <p>-&gt;140207, (140205) (...)=249357 cut -&gt;180203, (180201)</p> <p>SL 90mm AU 184mm</p>	<p><b>Additional Profiles</b></p> <p>IGI 620020</p> <p>229345 (CL)</p> <p>-&gt;690962x bl -&gt;690766 pw</p> <p>SL 65mm AU 119mm</p>	<p><b>Additional Profiles</b></p> <p>IGI 642025</p> <p>120224 (I)</p> <p>SL 31mm AU 99mm</p>	<p>1)  without lamination lamination</p> <p>2)  Classic-line (CL) Soft-line (SL) Round-line (RL)</p> <p>visible length exterior perimeter overall perimeter</p> <p>SL AU GU</p> <p>SL AU GU</p> <p>bl black w white pw papyrus-white gr grey br brown</p> <p>Mounting accessories</p> <p>Roller shutter slats mini-L - 8x37mm max-L - 14x52mm</p> <p>640951</p>
---	---	---	--	---	--	--	--	--	---

<p><b>Sash</b></p> <p>SL 79mm AU 154mm</p> <p>249486 (CL) 1</p> <p>-&gt;140x86 (CL)</p>	<p><b>IDEAL 4000</b></p> <p>SL 99mm AU 191mm</p> <p>249326 (CL) 1</p> <p>-&gt;140x26 (CL) -&gt;140x85 (CL)</p>	<p><b>Sash</b></p> <p>SL 67mm AU 127mm</p> <p>259386 (CL) 1</p> <p>-&gt;050x86 (CL)</p>	<p><b>IDEAL 5000</b></p> <p>SL 90mm AU 176mm</p> <p>259325 (CL) 1</p> <p>-&gt;150x25 (CL) -&gt;150x93 (CL)</p>	<p><b>Sash</b></p> <p>SL 79mm AU 149mm</p> <p>289420 (CL) 2</p> <p>-&gt;080x86 (CL) -&gt;180x20 (CL)</p>	<p><b>IDEAL 8000</b></p> <p>SL 90mm AU 176mm</p> <p>289326 (CL) 1</p> <p>-&gt;180x26 (CL)</p>	<p><b>Mullion Transoms</b></p> <p>SL 142mm AU 282mm</p> <p>249343 (CL)</p> <p>-&gt;140x45 (CL) -&gt;180x43 (CL) -&gt;150x44 (CL)</p>	<p><b>IDEAL 4000 / 5000</b></p> <p>SL 150mm AU 300mm</p> <p>289343 (CL)</p> <p>-&gt;180x43 (CL) -&gt;180x44 (CL) -&gt;180x45 (RL)</p>	<p><b>False mullion</b></p> <p>SL 101mm AU 198mm</p> <p>249366 (CL)</p> <p>-&gt;140x57 (SL) -&gt;140x69 (RL)</p>	<p><b>IDEAL 4000</b></p> <p>SL 81mm AU 155mm</p> <p>249365 (CL)</p> <p>-&gt;140x65 (CL)</p>	<p><b>False mullion</b></p> <p>SL 121mm AU 241mm</p> <p>249341 (CL) + Mullion Transoms</p> <p>-&gt;160x66 (RL) -&gt;180x66 (CL) -&gt;140x41 (CL) -&gt;140x44 (CL) -&gt;140x48 (SL) -&gt;150x41 (CL)</p>	<p><b>IDEAL 5000 / 8000</b></p> <p>SL 98mm AU 191mm</p> <p>259365 (CL)</p> <p>-&gt;150x65 (CL) -&gt;180x64 (CL)</p>	<p><b>False mullion</b></p> <p>SL 150mm AU 295mm</p> <p>259369 (CL)</p> <p>-&gt;150x69 (CL) -&gt;150x89 (CL)</p>	<p><b>IDEAL 5000</b></p> <p>SL 142mm AU 282mm</p> <p>289443 (RL)</p> <p>-&gt;180x43 (RL) -&gt;150x69 (CL) -&gt;180x45 (RL)</p>	<p><b>False mullion</b></p> <p>SL 116mm AU 225mm</p> <p>259366 (CL)</p> <p>-&gt;150x66 (CL)</p>	<p><b>False mullion</b></p> <p>SL 86mm AU 165mm</p> <p>259369 (CL)</p> <p>-&gt;180x69 (CL)</p>	<p><b>IDEAL 8000</b></p> <p>SL 153mm AU 304mm</p> <p>289369 (CL)</p> <p>-&gt;180x69 (CL)</p>	<p><b>False mullion</b></p> <p>SL 98mm AU 191mm</p> <p>289346 (CL)</p> <p>-&gt;180x46 (CL) -&gt;180x47 (CL)</p>	<p><b>False mullion</b></p> <p>SL 99mm AU 191mm</p> <p>289465 (RL)</p> <p>-&gt;180x65 (RL)</p>
---	--	---	--	--	---	--	---	--	---	---	---	--	--	---	--	--	---	--

<p><b>BI Inlet funnel</b></p> <p>620038</p> <p>-&gt;190430 -&gt;190435 -&gt;500504 RI 260446 RI 260407</p>	<p><b>IC End caps</b></p> <p>682260 IT1 2821152xx</p> <p>500511 -&gt;500502 -&gt;500503 -&gt;500926 RI 500627 -&gt;500504 -&gt;500605 RI 500628 RI 500629</p>	<p><b>IGI Nipple screw / Clip</b></p> <p>620020 500510</p> <p>659923 680039</p> <p>-&gt;2821152xx</p> <p><b>IHI Installation / Installation anchor</b></p> <p>642025</p> <p>-&gt;120224 Coupling profile</p>	<p><b>RI Aluminium roller shutter guides</b></p> <p>Roller shutter box</p> <p>260406 SL 100mm IGI 620038 AU 333mm IGI 659923 GU 579mm IYI 457930, 459930-&gt;maxi-L 459932-&gt;mini-L</p> <p>260407 SL 131mm IGI 620038 AU 435mm IGI 659923 GU 715mm IYI 457930, 459930-&gt;maxi-L 459932-&gt;mini-L</p> <p>500626 SL 105mm IGI 500908 AU 555mm IGI 500511 IGI 500510 IYI 500539-&gt;mini-L</p> <p>500628 SL 128mm IGI 500908 AU 629mm IGI 500511 GU 730mm IGI 500510 IYI 500539-&gt;mini-L</p>	<p><b>ISI Aluminium profiles</b></p> <p>229080 SL 63mm AU 205mm GU 371mm</p> <p>229246 SL 107mm AU 258mm GU 302mm</p>	<p><b>ITI Aluminium weather bar</b></p> <p>2821152xx SL 31mm AU 99mm</p>	<p><b>IXI Gaskets</b></p> <p>459951 bl or 449986 bl -&gt;Glazing</p> <p>429320 bl or 449346 bl -&gt;Stop</p>	<p><b>IYI Brush seals</b></p> <p>459930 bl or 459932 gr -&gt;maxi-L RI 260406, 260407 -&gt;mini-L RI 260406, 260407</p> <p>500539 gr RI 500626, 500628</p>
--	---	--	---	---	--	--	--



aluplast GmbH | uPVC window profile systems
Auf der Breit 2 | D-76227 Karlsruhe
Tel. +49 (721) 47171-0 | Fax: 999
info@aluplast.de | www.aluplast.de

IF Reinforcements

Table with multiple columns showing reinforcement profiles with dimensions (lx, ly, thickness s), part numbers, and technical drawings. Includes various profiles for different window and door systems.

1) lx [cm] -> aluminium x 0,334 = Steel

2) punched out

IE Corner connector

Depending on the installation situation, some reinforcements may have to be turned 90°. In this case, the lx- and ly-values have to be exchanged.

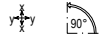

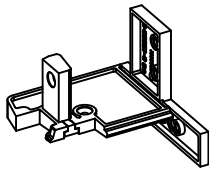

686071 connection for threshold  
-> 269060 threshold 20/85mm  
-> 249058 threshold 20/120mm

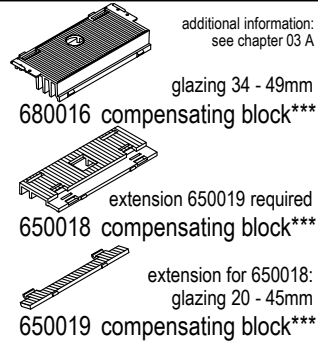

additional information:  
see chapter 03 A

glazing 34 - 49mm

680016 compensating block\*\*\*

extension 650019 required

650018 compensating block\*\*\*

extension for 650018:  
glazing 20 - 45mm

650019 compensating block\*\*\*

**080x05  
FRAME  
80mm  
fibre-reinforced**

Rahmen  
dormant  
telaio  
marco  
**Classic-line**

■ Fibre-reinforced profile (powerdur inside)  
● Reinforcement only as additional option

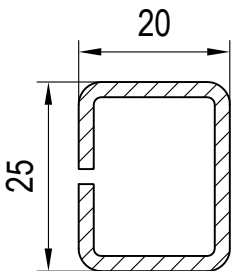

229117 s=2.0mm 0.8\*  
229119 s=1.5mm 0.6\*

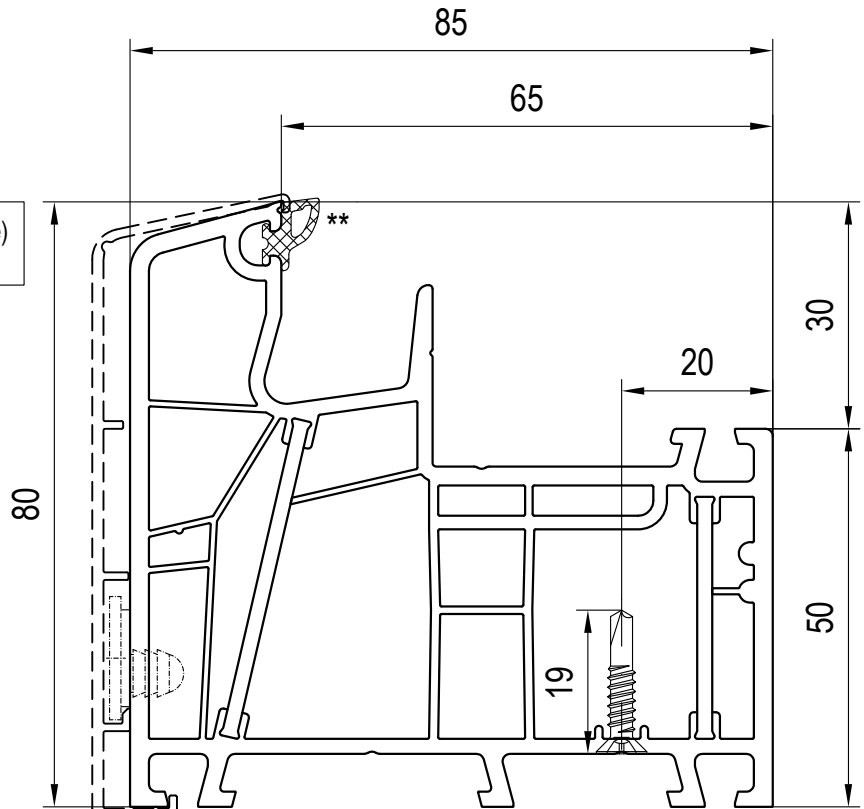

289313 aluminium shell (CL)  
compatible clamp clip: 620020



Fix reinforcement in the profile with self-drilling window screws, e.g.: FD21 3.9 x 19mm.

\* Ix-value in cm<sup>4</sup>

\*\* Gasket(s) inserted in factory: see current price list.

\*\*\* Compensating block: Only in the case of fixed glazing if centre gasket strip has been cut off!

May be subject to change  
and errors excepted!

scale: 1:1  
02\_B\_01\_8\*

**Main Profiles: Frames  
Frame, 80mm: 080x05**



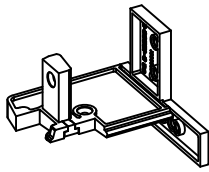

686071 connection for threshold  
-> 269060 threshold 20/85mm  
-> 249058 threshold 20/120mm

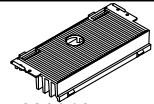

additional information:  
see chapter 03 A  
glazing 34 - 49mm  
680016 compensating block\*\*\*

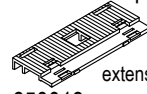

extension 650019 required  
650018 compensating block\*\*\*

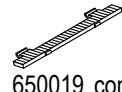

extension for 650018:  
glazing 20 - 45mm  
650019 compensating block\*\*\*

180x05  
FRAME  
80mm

Rahmen  
dormant  
telaio  
marco  
Classic-line

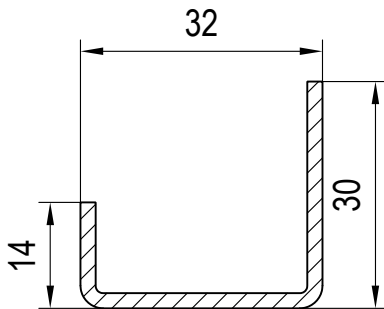

239019 s=1.5mm 1.6\*  
239020 s=2.0mm 2.1\*

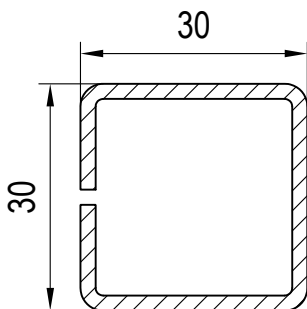

229112 s=1.2mm 1.8\*  
229113 s=2.0mm 2.7\*

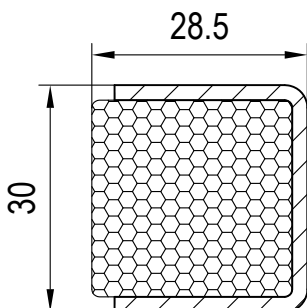

250101 s=2.0mm 1.0\*

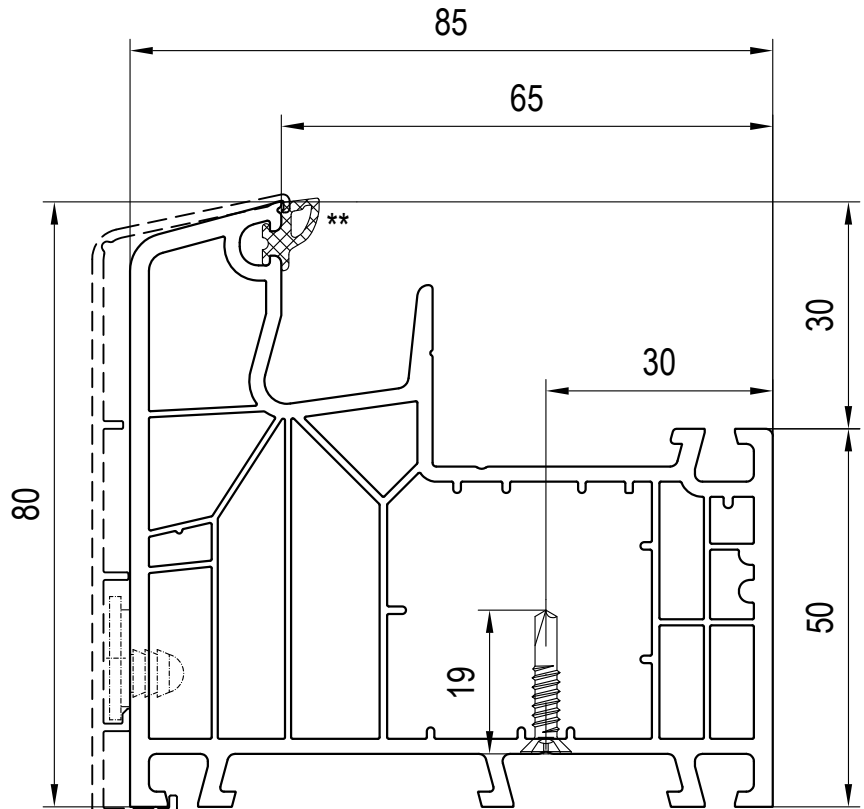

289313 aluminium shell (CL)  
compatible clamp clip 620020



Fix reinforcement in the profile with self-drilling window screws, e.g.: FD21 3.9 x 19mm.

\* Ix-value in cm<sup>4</sup>

\*\* Gasket(s) inserted in factory: see current price list.

\*\*\* Compensating block: Only in the case of fixed glazing if centre gasket strip has been cut off!

May be subject to change  
and errors excepted!

scale: 1:1  
02\_B\_01\_8\*

Main Profiles: Frames  
Frame, 80mm: 180x05

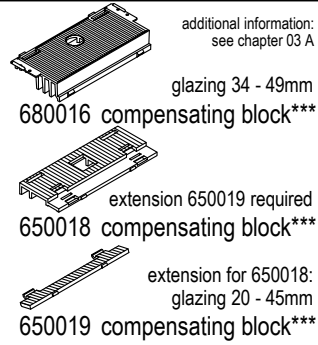

180x04  
FRAME  
100mm

Rahmen  
dormant  
telaio  
marco  
Classic-line

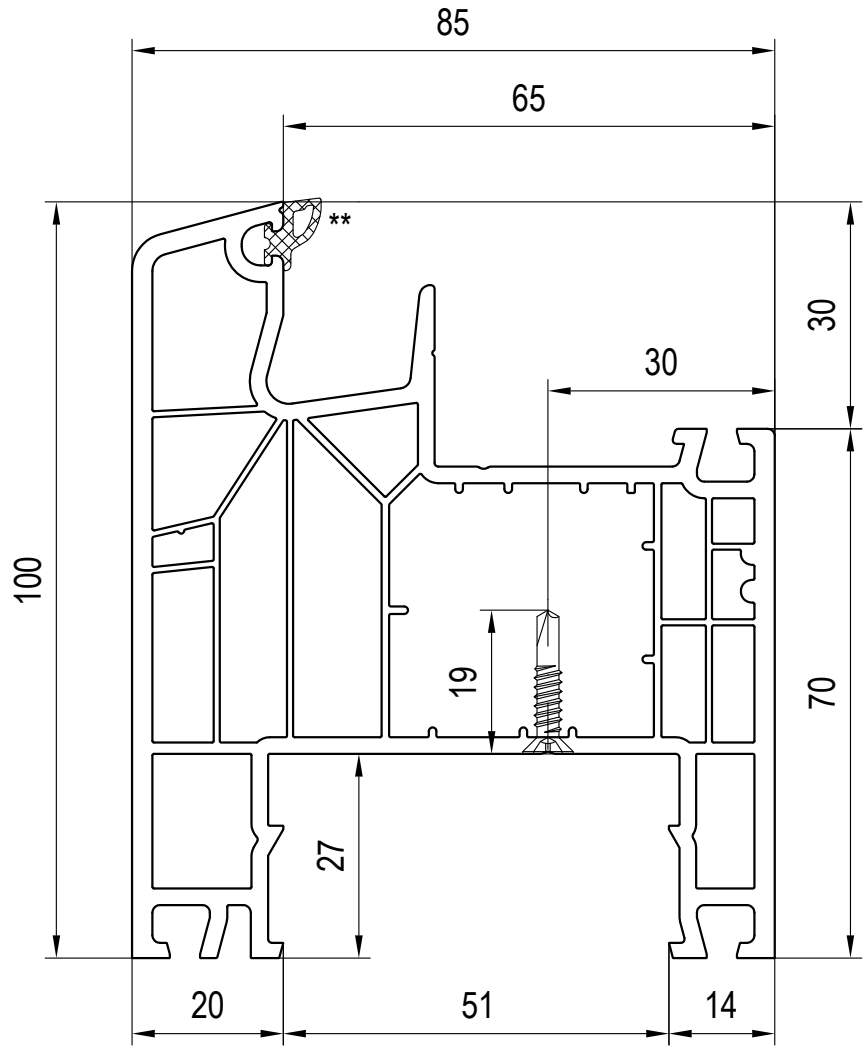
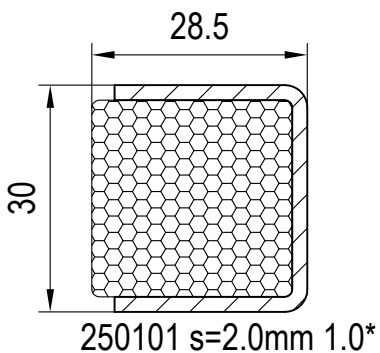
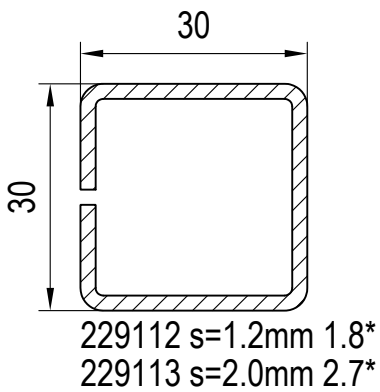
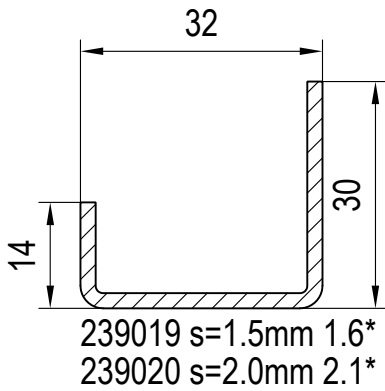

Fix reinforcement in the profile with self-drilling window screws, e.g.: FD21 3.9 x 19mm.

\* Ix-value in cm<sup>4</sup>

\*\* Gasket(s) inserted in factory: see current price list.

\*\*\* Compensating block: Only in the case of fixed glazing if centre gasket strip has been cut off!

May be subject to change  
and errors excepted!

scale: 1:1  
02\_B\_01\_8\*

Main Profiles: Frames  
Frame, 100mm: 180x04

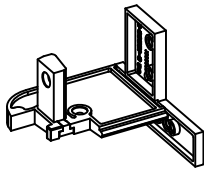

686070 connection for threshold  
-> 269060 threshold 20/85mm  
-> 249058 threshold 20/120mm

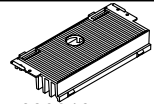

additional information:  
see chapter 03 A  
glazing 34 - 49mm  
680016 compensating block\*\*\*

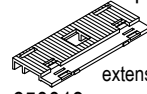

extension 650019 required  
650018 compensating block\*\*\*



extension for 650018:  
glazing 20 - 45mm  
650019 compensating block\*\*\*

180x03  
FRAME  
80mm

Rahmen  
dormant  
telaio  
marco  
Round-line

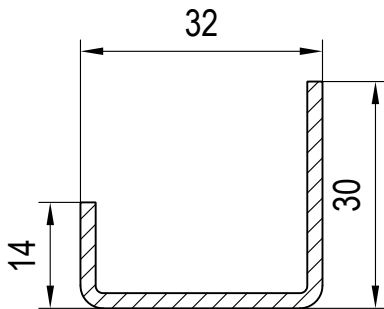

239019 s=1.5mm 1.6\*  
239020 s=2.0mm 2.1\*

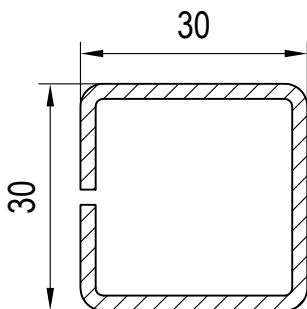

229112 s=1.2mm 1.8\*  
229113 s=2.0mm 2.7\*

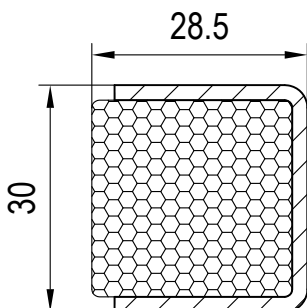

250101 s=2.0mm 1.0\*

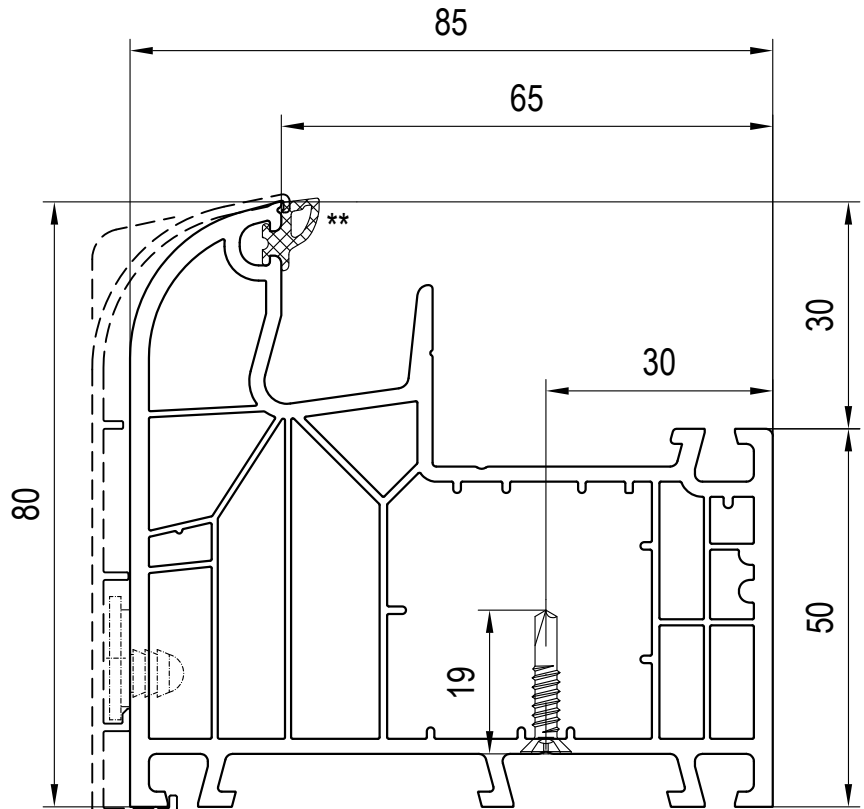

289413 aluminium shell (RL)  
289313 aluminium shell (CL)  
compatible clamp clip 620020



Fix reinforcement in the profile with self-drilling window screws, e.g.: FD21 3.9 x 19mm.

\* Ix-value in cm<sup>4</sup>

\*\* Gasket(s) inserted in factory: see current price list.

\*\*\* Compensating block: Only in the case of fixed glazing if centre gasket strip has been cut off!

May be subject to change  
and errors excepted!

scale: 1:1  
02\_B\_01\_8\*

Main Profiles: Frames  
Frame, 80mm: 180x03

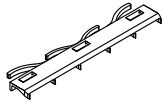

rebate support element  
645234 (4.5mm  
black)

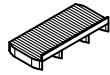

support element  
640033 (3mm red)  
640034 (4mm yellow)  
640035 (5mm green)

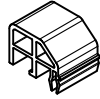

spacer  
640015 (12mm white)  
640014 (13mm red)  
640019 (14mm yellow)



spacer  
640113 (13mm red)  
640114 (14mm yellow)

080x86  
SASH  
recessed 77mm  
bonding of pane  
fibre-reinforced

Flügel  
ouvrant  
anta  
hoja  
Classic-line

■ Fibre-reinforced profile!  
(powerdur inside)  
● Reinforcement only as  
an additional option

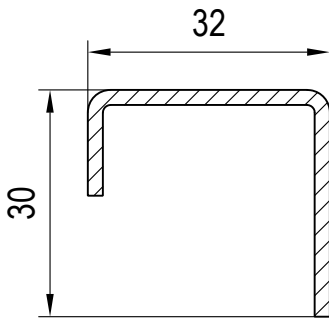

239019 s=1.5mm 1.6\*  
239020 s=2.0mm 2.1\*

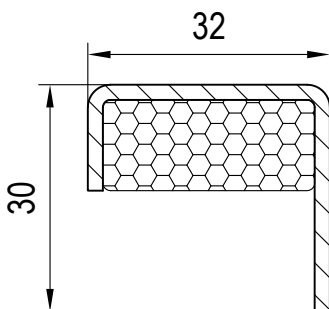

250102 s=2.0mm 2.1\*

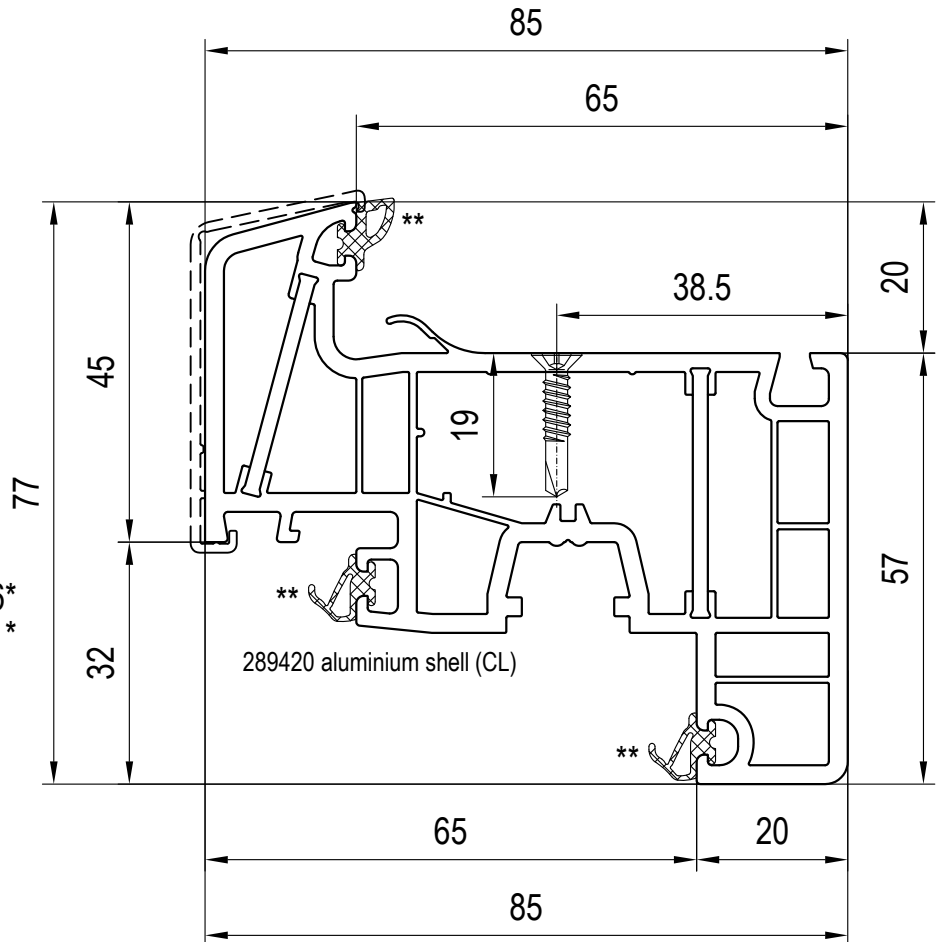

Fix reinforcement in the profile with self-drilling  
window screws, e.g.: FD21 3.9 x 19mm.  
Seal screw heads in the horizontal bottom rebate.

\* Ix-value in cm<sup>4</sup>

\*\* Gasket(s) inserted in factory: see current price list

May be subject to change  
and errors excepted!

scale: 1:1  
02\_C\_01\_8\*

Main Profiles: Sashes  
Sash, Recessed, 77mm, Bonding of Pane: 080x86

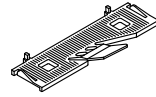

620301 compensating block

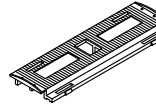

620305 compensating block with integrated 5mm-spacer (only for glazing <24mm)

180x20  
SASH  
recessed 77mm

Flügel  
ouvrant  
anta  
hoja  
Classic-line

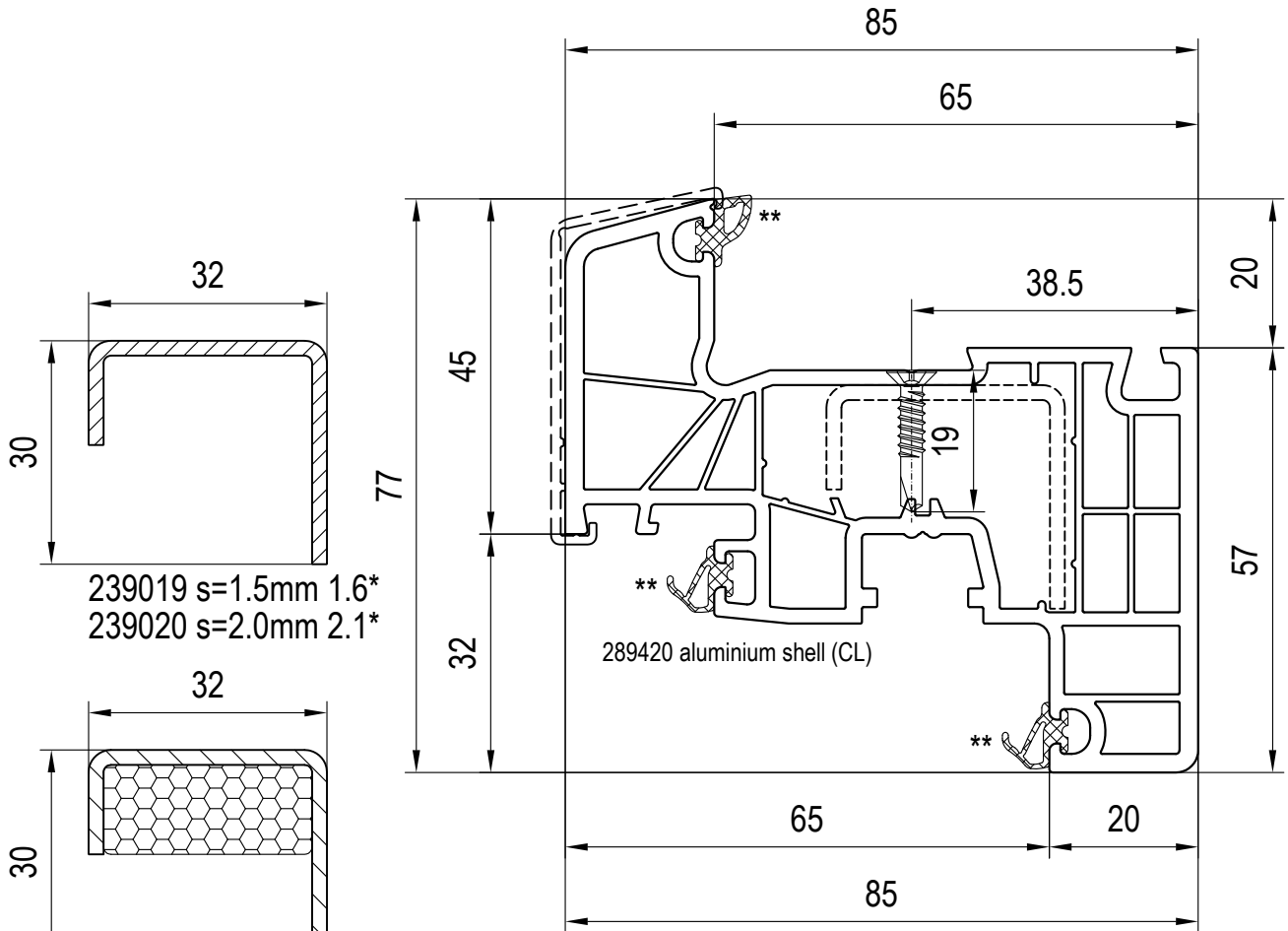

Fix reinforcement in the profile with self-drilling window screws, e.g.: FD21 3.9 x 19mm. Seal screw heads in the horizontal bottom rebate.

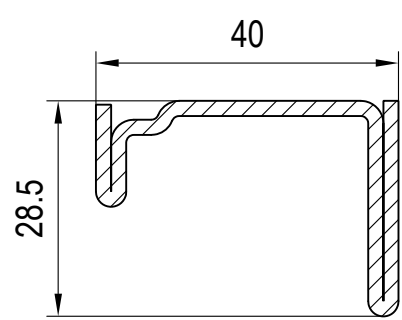
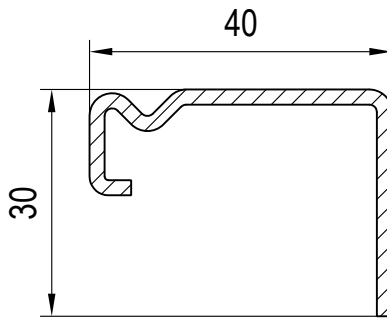
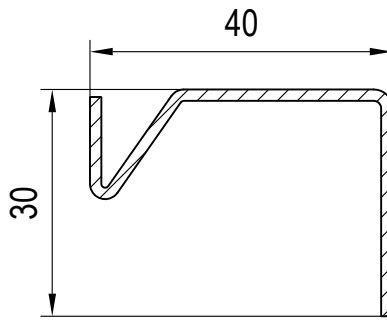
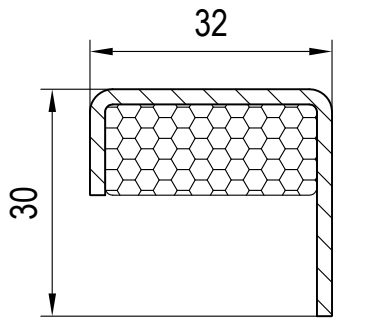
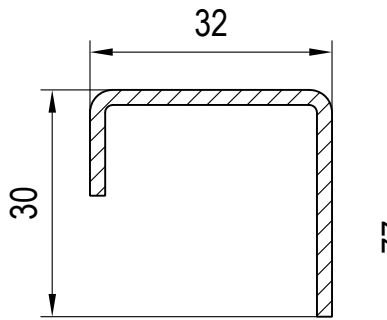

\* Ix-value in cm<sup>4</sup>

\*\* Gasket(s) inserted in factory: see current price list

May be subject to change and errors excepted!

scale: 1:1  
02\_C\_01\_8\*

Main Profiles: Sashes  
Sash, Recessed, 77mm: 180x20

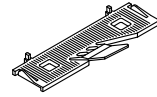

620301 compensating block

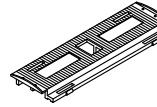

620305 compensating block  
with integrated 5mm-spacer  
(only for glazing <24mm)

180x30  
SASH  
recessed 105mm

Flügel  
ouvrant  
anta  
hoja  
Classic-line

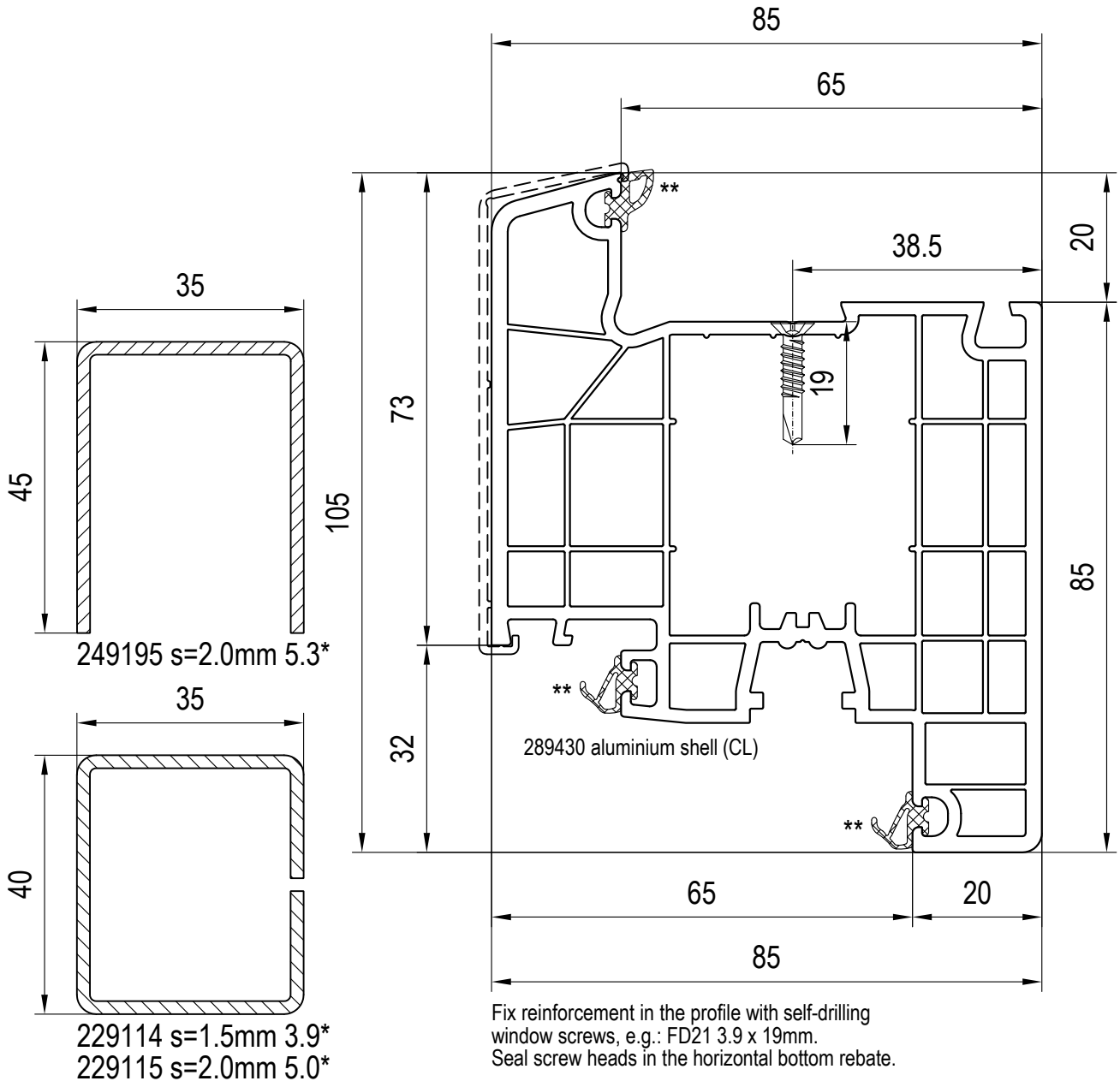

Fix reinforcement in the profile with self-drilling  
window screws, e.g.: FD21 3.9 x 19mm.  
Seal screw heads in the horizontal bottom rebate.

\* Ix-value in cm<sup>4</sup>

\*\* Gasket(s) inserted in factory: see current price list

May be subject to change  
and errors excepted!

scale: 1:1  
02\_C\_01\_8\*

Main Profiles: Sashes  
Sash, Recessed, 105mm: 180x30

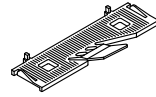

620301 compensating block

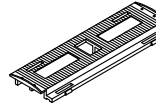

620305 compensating block with integrated 5mm-spacer (only for glazing <24mm)

180x31  
SASH  
recessed 105mm  
opening outwards

Flügel  
ouvrant  
anta  
hoja  
Classic-line

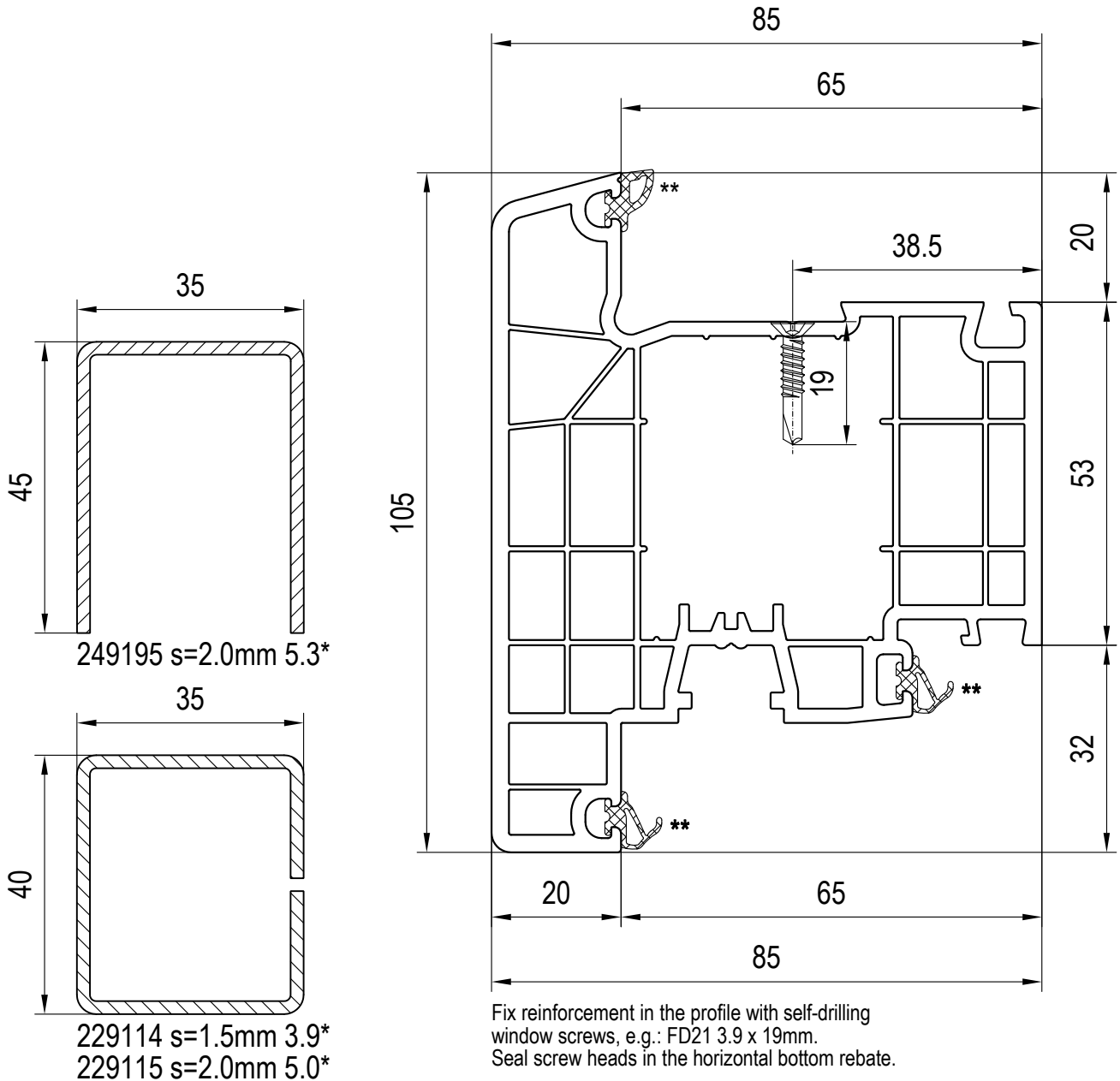

Fix reinforcement in the profile with self-drilling window screws, e.g.: FD21 3.9 x 19mm.  
Seal screw heads in the horizontal bottom rebate.

\* Ix-value in cm<sup>4</sup>

\*\* Gasket(s) inserted in factory: see current price list

May be subject to change and errors excepted!

scale: 1:1  
02\_C\_01\_8\*

**Main Profiles: Sashes**  
**Opening Outwards, Sash, Recessed, 105mm: 180x31**

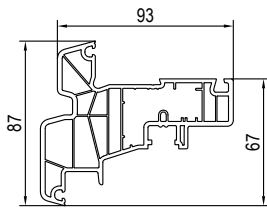

180x69  
compatible false mullion sash (CL)

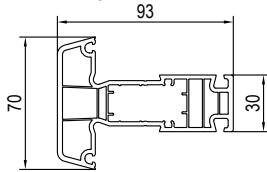

180x47  
compatible transom (CL)

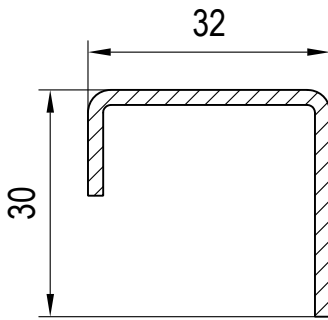

239019 s=1.5mm 1.6\*  
239020 s=2.0mm 2.1\*

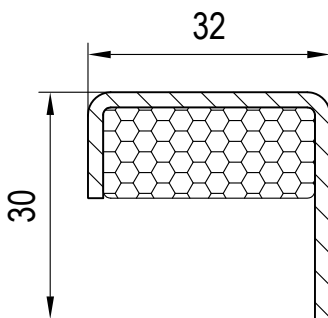

250102 s=1.5mm 2.1\*

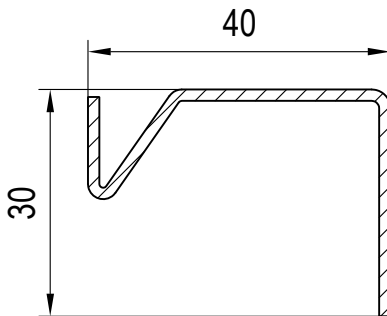

259025 s=1.5mm 3.1\*

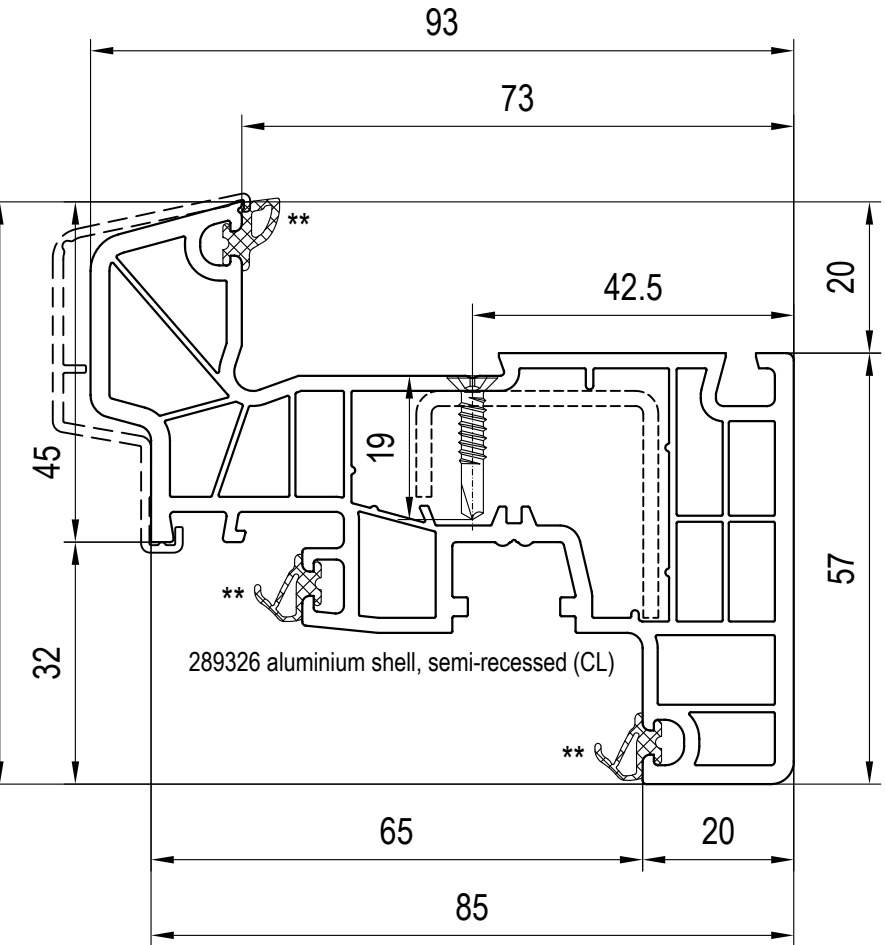

Fix reinforcement in the profile with self-drilling window screws, e.g.: FD21 3.9 x 19mm.  
Seal screw heads in the horizontal bottom rebate.

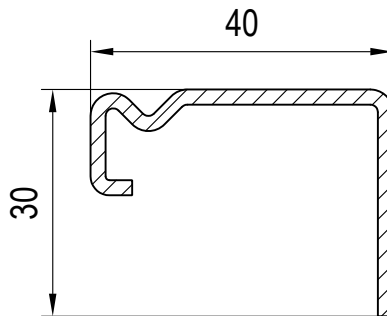

259002 s=2.0mm 3.9\*

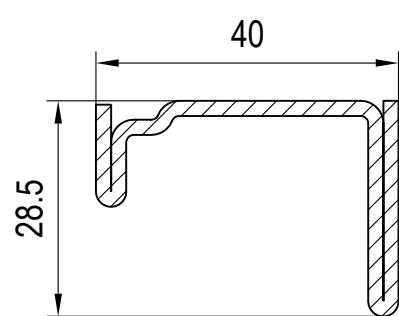

249025 s=2.0mm 5.1\*

180x26  
SASH  
semi-recessed 77mm  
extended rebate

Flügel  
ouvrant  
anta  
hoja  
Classic-line

\* Ix-value in cm<sup>4</sup>

\*\* Gasket(s) inserted in factory: see current price list

May be subject to change and errors excepted!

scale: 1:1  
02\_C\_01\_8\*



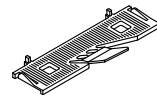

620301 compensating block

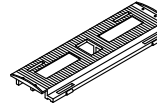

620305 compensating block  
with integrated 5mm-spacer  
(only for glazing <24mm)

180x22  
SASH  
recessed 77mm

Flügel  
ouvrant  
anta  
hoja  
Round-line

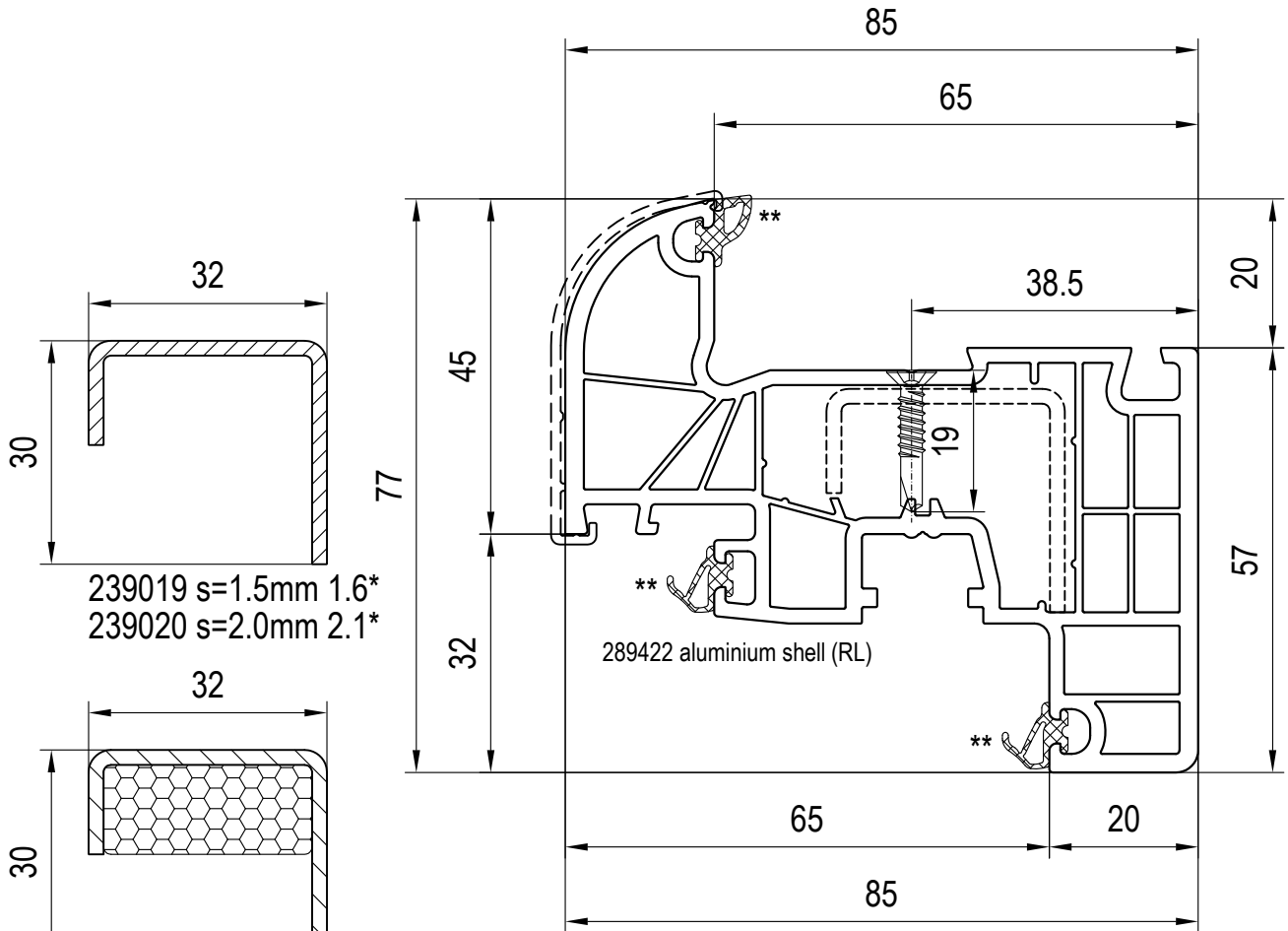

Fix reinforcement in the profile with self-drilling  
window screws, e.g.: FD21 3.9 x 19mm.  
Seal screw heads in the horizontal bottom rebate.

\* Ix-value in cm<sup>4</sup>

\*\* Gasket(s) inserted in factory: see current price list

May be subject to change  
and errors excepted!

scale: 1:1  
02\_C\_01\_8\*

Main Profiles: Sashes  
Sash, Recessed, 77mm: 180x22

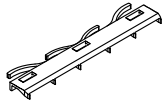

rebate support element  
645234 (4.5mm black)

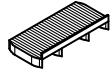

support element  
640033 (3mm red)  
640034 (4mm yellow)  
640035 (5mm green)



spacer  
640015 (12mm white)  
640014 (13mm red)  
640019 (14mm yellow)



spacer  
640113 (13mm red)  
640114 (14mm yellow)

180x83  
SASH  
recessed 77mm  
bonding of pane

Flügel  
ouvrant  
anta  
hoja  
Round-line

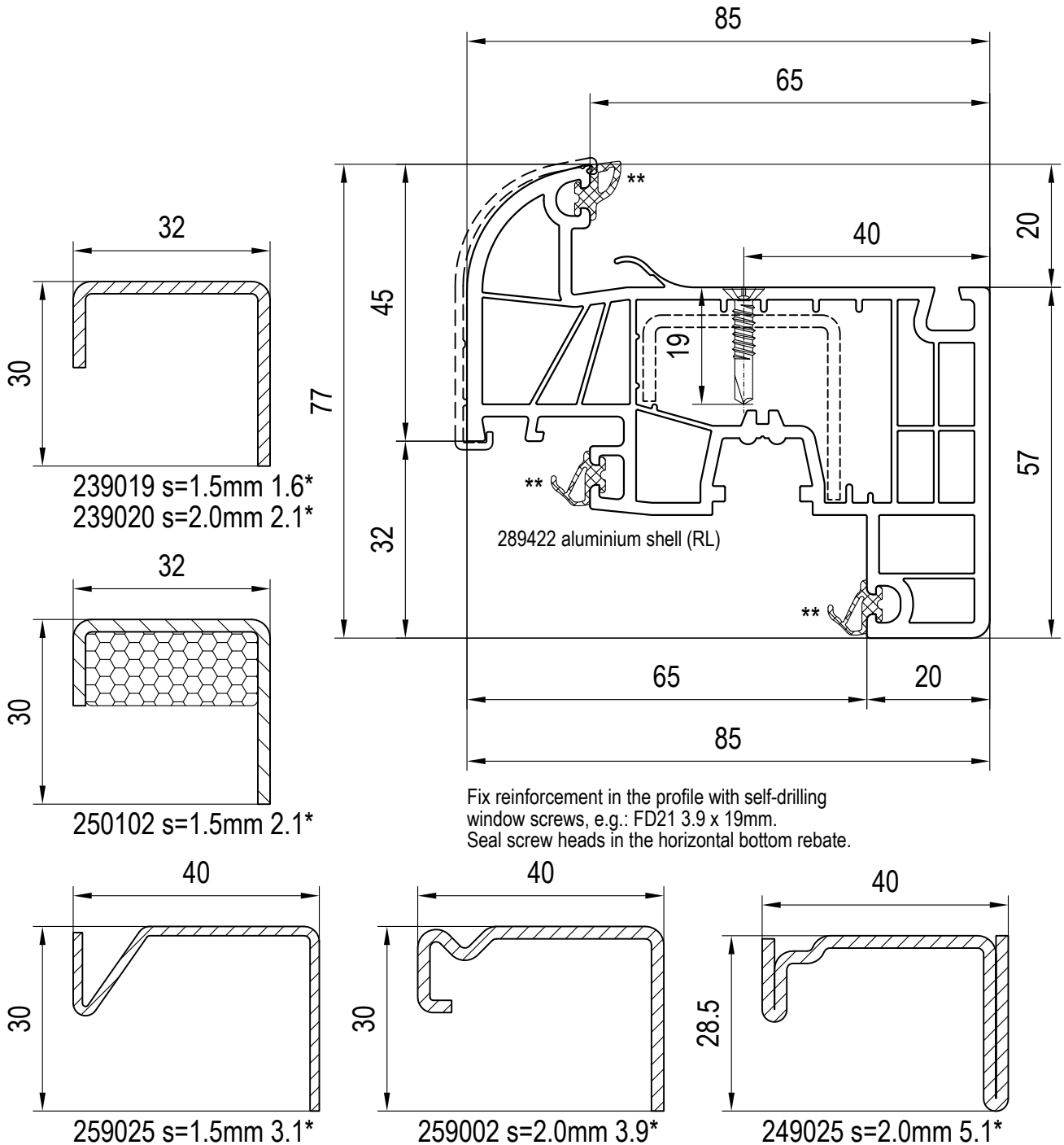

\* Ix-value in cm<sup>4</sup>

\*\* Gasket(s) inserted in factory: see current price list

May be subject to change  
and errors excepted!

scale: 1:1  
02\_C\_01\_8\*

Main Profiles: Sashes  
Sash, Recessed, 77mm, Bonding of Pane: 180x83

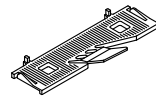

620301 compensating block

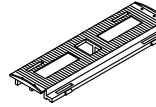

620305 compensating block with integrated 5mm-spacer (only for glazing <24mm)

180x32  
SASH  
recessed 105mm

Flügel  
ouvrant  
anta  
hoja  
Round-line

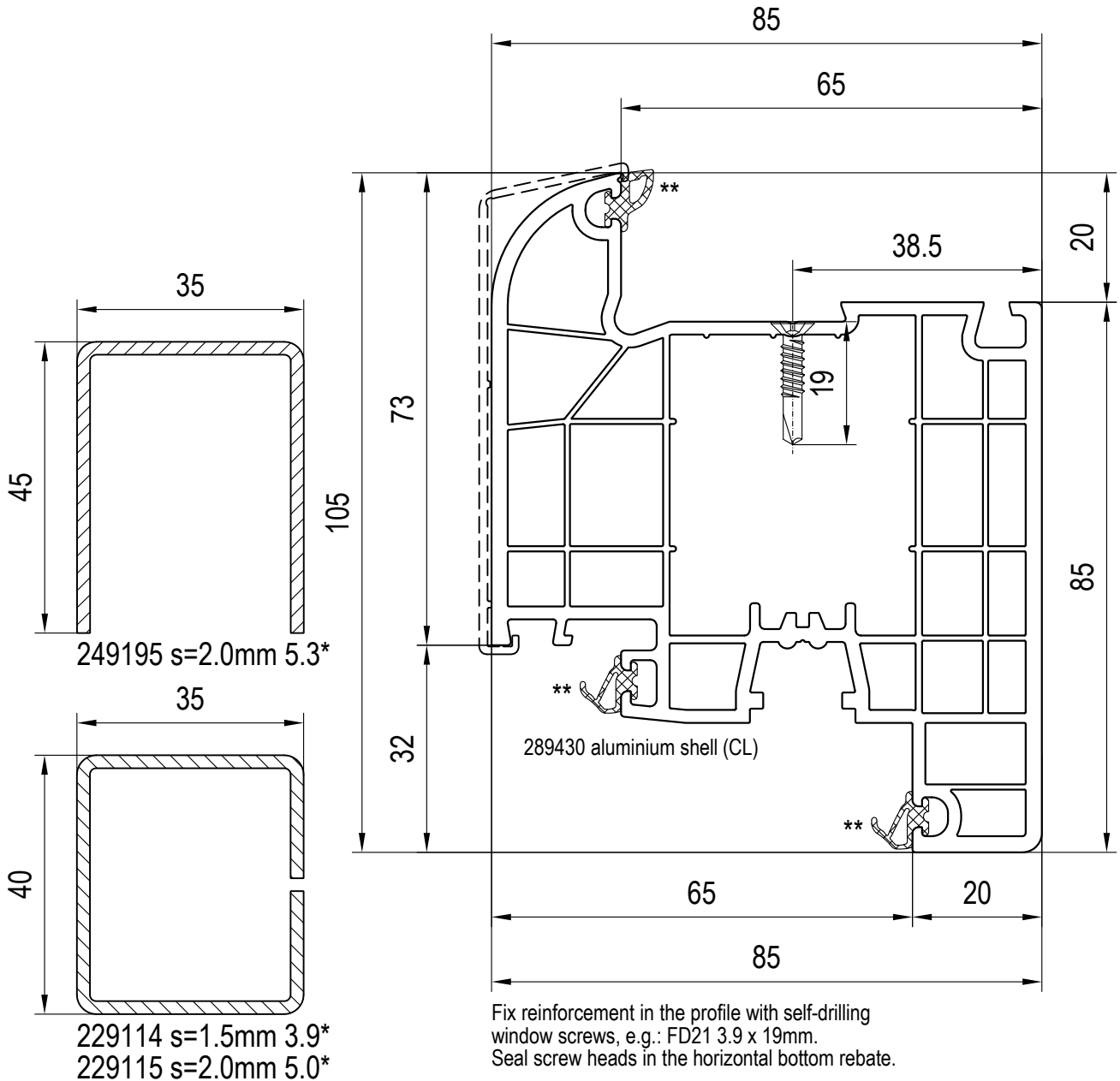

\* Ix-value in cm<sup>4</sup>

\*\* Gasket(s) inserted in factory: see current price list

May be subject to change and errors excepted!

scale: 1:1  
02\_C\_01\_8\*

Main Profiles: Sashes  
Sash, Recessed, 105mm: 180x32

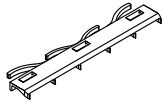

rebate support element  
645234 (4.5mm black)

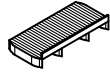

support element  
640033 (3mm red)  
640034 (4mm yellow)  
640035 (5mm green)



spacer  
640015 (12mm white)  
640014 (13mm red)  
640019 (14mm yellow)



spacer  
640113 (13mm red)  
640114 (14mm yellow)

180x85  
SASH  
semi-recessed 77mm  
bonding of pane

Flügel  
ouvrant  
anta  
hoja  
Round-line

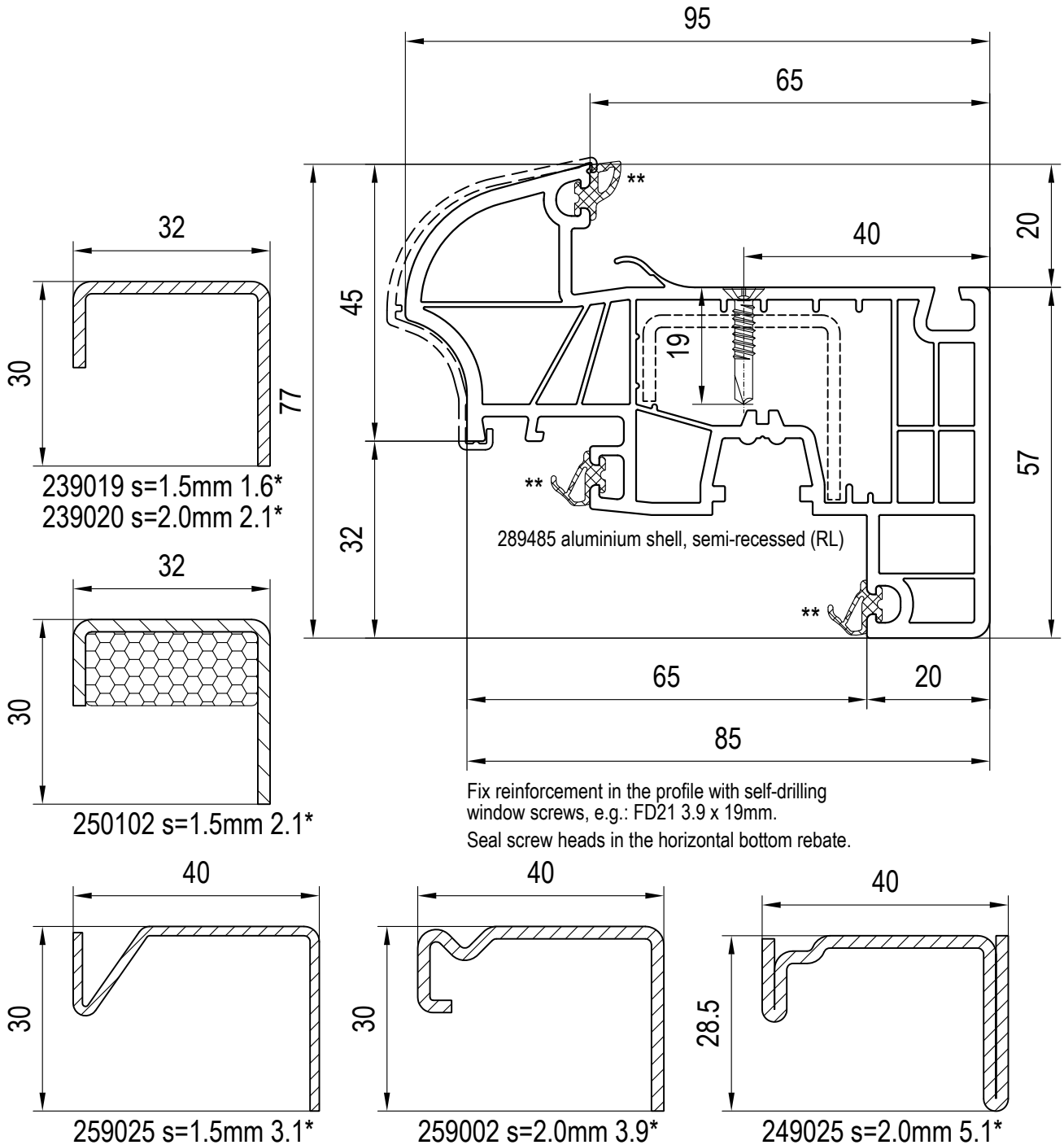

\* Ix-value in cm<sup>4</sup>

\*\* Gasket(s) inserted in factory: see current price list

May be subject to change  
and errors excepted!

scale: 1:1  
02\_C\_01\_8\*

Main Profiles: Sashes  
Sash, Semi-Recessed, 77mm, Bonding of Pane: 180x85

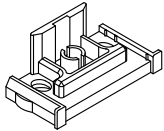

metal mullion connector  
657130 with sticks  
657030 without sticks

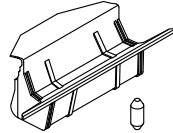

gasket block for  
circumferential gaskets  
650032 white  
659032 black

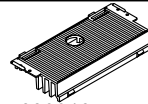

additional information:  
see chapter 03 A  
glazing 34 - 49mm  
680016 compensating block\*\*\*

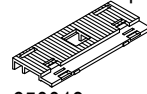

extension 650019  
required  
650018 compensating block\*\*\*

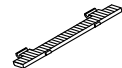

extension for 650018:  
glazing 20 - 45mm  
650019 compensating block\*\*\*

**180x44  
MULLION  
104mm**

Pfosten  
meneau  
montante  
poste  
**Classic-line**

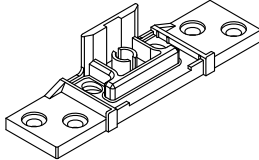

metal cross connector  
657134 with sticks  
657034 without sticks

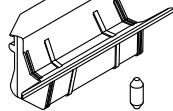

gasket block for  
non-circumferential  
gaskets  
650033 white  
659033 black

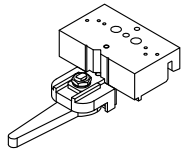

680900 drilling jig  
-> 657130 / 030 mullion connector  
-> 657134 / 034 cross connector  
-> 180x45 transom

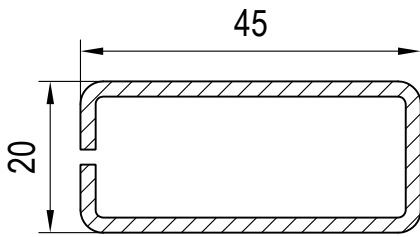

229102 s=2.0mm 5.4\*  
229103 s=3.0mm 7.3\*

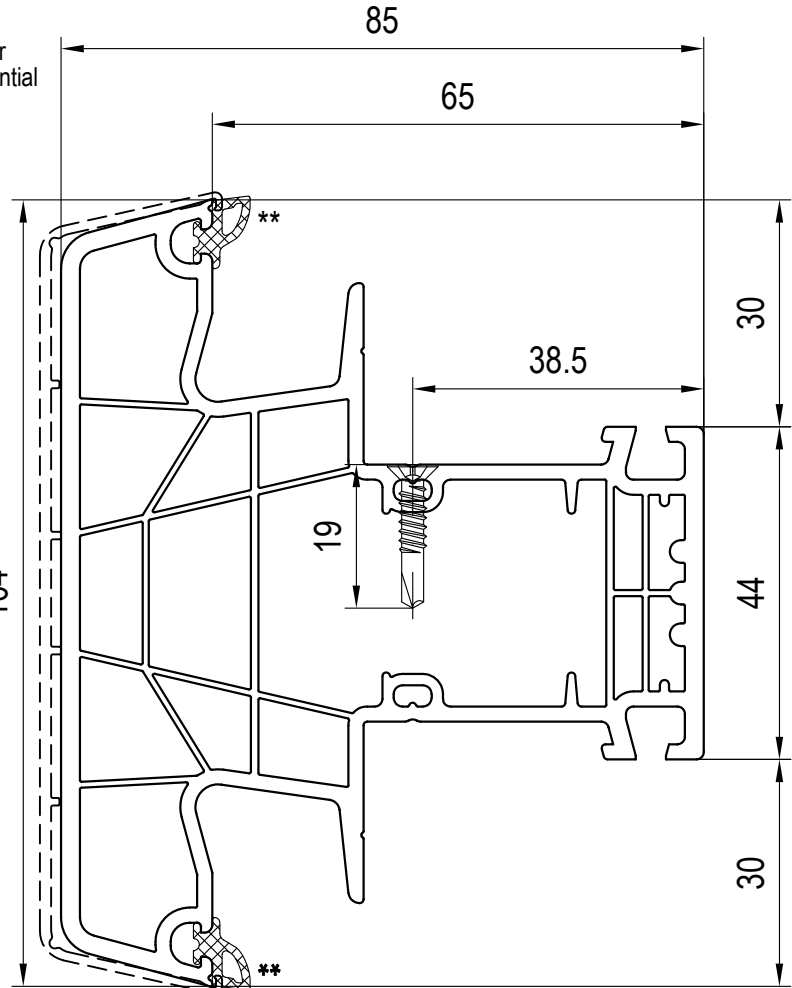

289343 aluminium shell (CL)

Fix reinforcement in the profile with self-drilling  
window screws, e.g.: FD21 3.9 x 19mm.  
Seal screw heads in the horizontal bottom rebate.

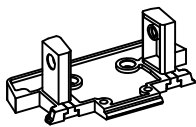

686073 mullion coupler  
-> 269060 threshold 20/85mm  
-> 249058 threshold 20/120mm

\* Ix-value in cm<sup>4</sup>

\*\* Gasket(s) inserted in factory: see current price list

\*\*\* Compensating block: Only in the case of fixed glazing if centre gasket stick has been cut off!

May be subject to change  
and errors excepted!

scale: 1:1  
02\_D\_01\_8\*

**Main Profiles: Mullions / Transoms**  
**Mullion, 104mm: 180x44**

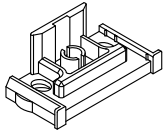

metal mullion connector  
657130 with sticks  
657030 without sticks

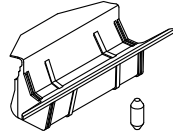

gasket block for  
circumferential gasket  
650032 white  
659032 black

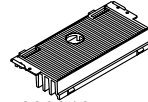

680016 compensating block\*\*\*  
additional information:  
see chapter 03 A



650018 compensating block\*\*\*  
extension 650019  
required

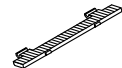

650019 compensating block\*\*\*  
extension for 650018:  
glazing 20 - 45mm

**180x43  
MULLION  
104mm**

Pfosten  
meneau  
montante  
poste  
**Round-line**

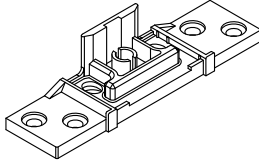

metal cross connector  
657134 with sticks  
657034 without sticks

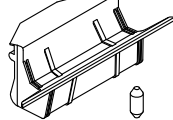

gasket block for  
non-circumferential  
gasket  
650033 white  
659033 black

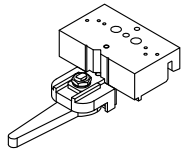

680900 drilling jig  
-> 657130 / 030 mullion connector  
-> 657134 / 034 cross connector  
-> 180x45 transom

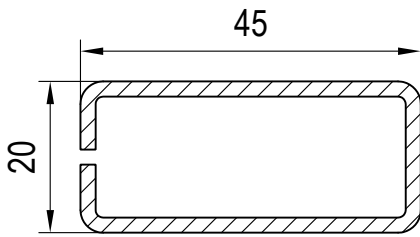

229102 s=2.0mm 5.4\*  
229103 s=3.0mm 7.3\*

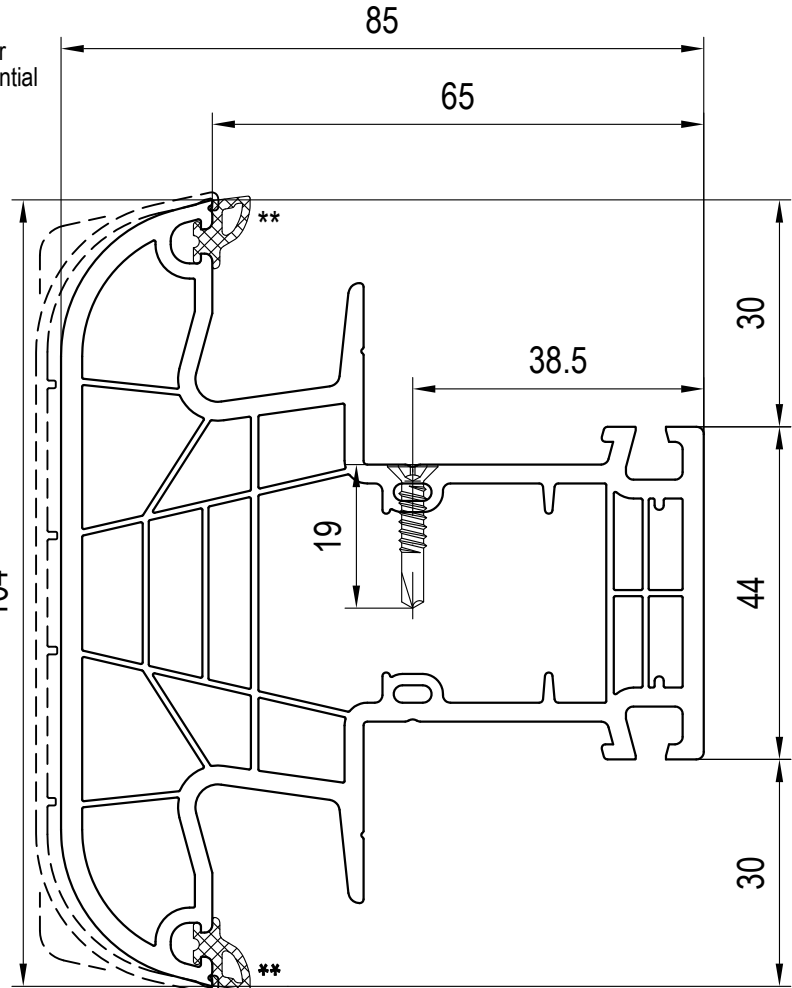

289443 aluminium shell (RL)

289343 aluminium shell (CL)

Fix reinforcement in the profile with self-drilling  
window screws, e.g.: FD21 3.9 x 19mm.  
Seal screw heads in the horizontal bottom rebate.

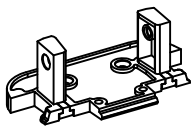

686072 mullion coupler  
-> 269060 threshold 20/85mm  
-> 249058 threshold 20/120mm

\* Ix-value in cm<sup>4</sup>

\*\* Gasket(s) inserted in factory: see current price list

\*\*\* Compensating block: Only in the case of fixed glazing if centre gasket stick has been cut off!

May be subject to change  
and errors excepted!

scale: 1:1  
02\_D\_01\_8\*

**Main Profiles: Mullions / Transoms**  
**Mullion, 104mm: 180x43**

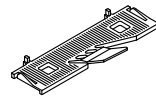

620301 compensating block

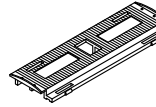

620305 compensating block  
with integrated 5mm-spacer  
(for glazing <24mm only)

180x46  
TRANSOM  
70mm

Sprosse  
traverse  
traverso  
travesaño  
Classic-line

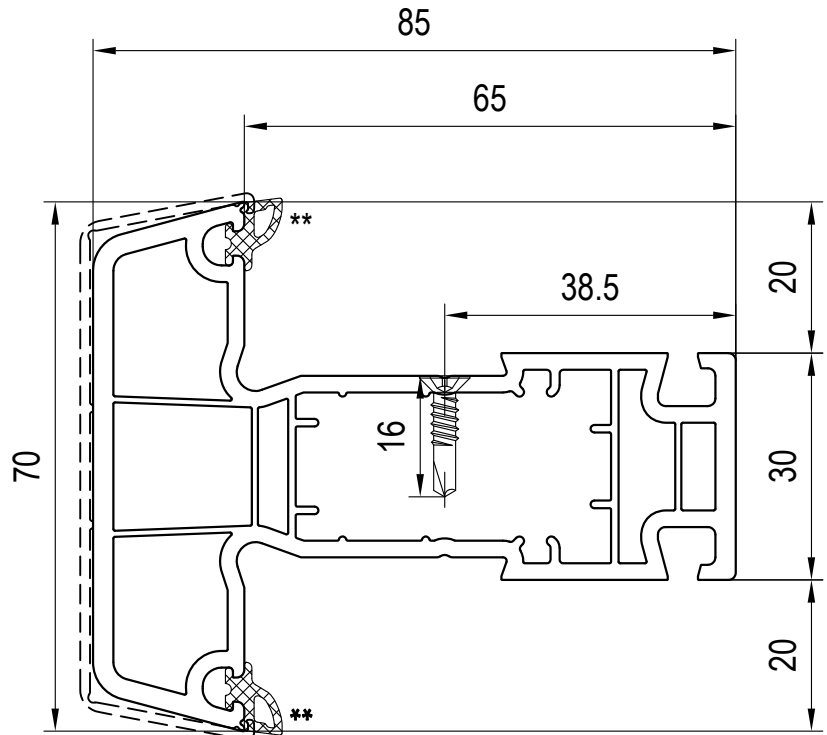
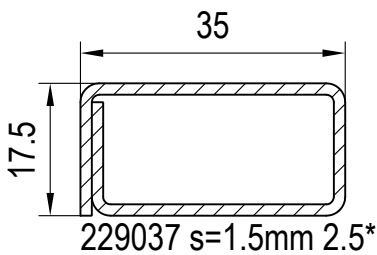

289346 aluminium shell (CL)

Fix reinforcement in the profile with self-drilling  
window screws, e.g.: FD21 3.9 x 16mm.  
Seal screw heads in the horizontal bottom rebate.

transom connector: TBA

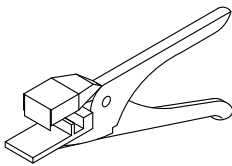

640940 gasket scissors  
for transoms  
with pre-inserted gasket

\* Ix-value in cm<sup>4</sup>

\*\* Gasket(s) inserted in factory: see current price list

May be subject to change  
and errors excepted!

scale: 1:1  
02\_D\_01\_8\*

Main Profiles: Mullions / Transoms  
Transom, 70mm: 180x46

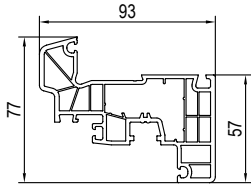

180x26  
compatible sash (CL)

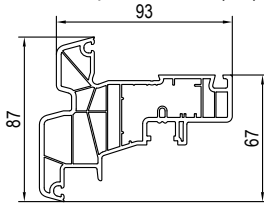

180x69  
compatible false mullion sash (CL)

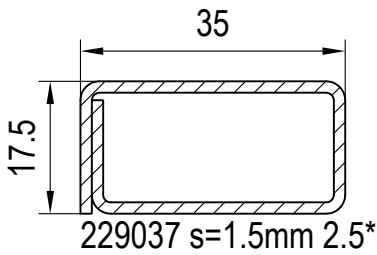

229037 s=1.5mm 2.5\*

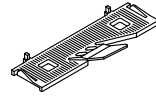

620301 compensating block

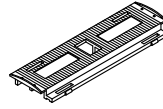

620305 compensating block  
with integrated 5mm-spacer  
(for glazing <24mm only)

180x47  
TRANSOM  
70mm  
extended rebate

Sprosse  
traverse  
traverso  
travesaño  
Classic-line

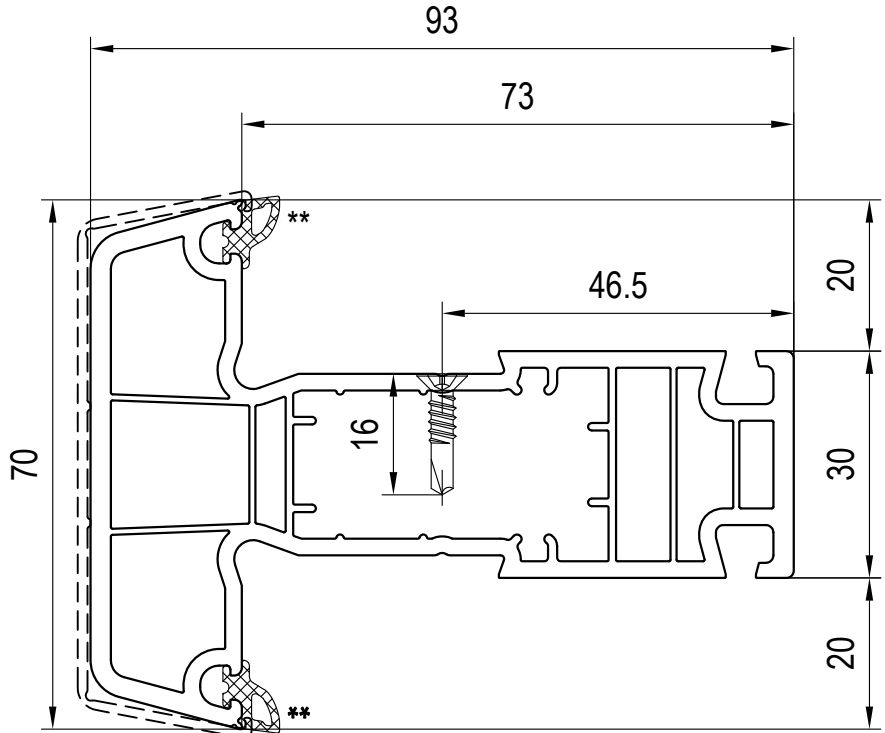

289346 aluminium shell (CL)

Fix reinforcement in the profile with self-drilling  
window screws, e.g.: FD21 3.9 x 16mm.  
Seal screw heads in the horizontal bottom rebate.

transom connector: TBA

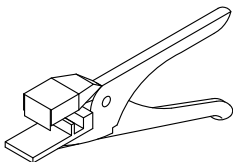

640940 gasket scissors  
for transoms  
with pre-inserted gasket

\* Ix-value in cm<sup>4</sup>

\*\* Gasket(s) inserted in factory: see current price list

May be subject to change  
and errors excepted!

scale: 1:1  
02\_D\_01\_8\*

Main Profiles: Mullions / Transoms  
Extended Rebate, Transom, 70mm: 180x47



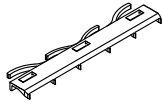

rebate support element  
645234 (4.5mm black)

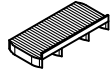

support element  
640033 (3mm red)  
640034 (4mm yellow)  
640035 (5mm green)



spacer  
640015 (12mm white)  
640014 (13mm red)  
640019 (14mm yellow)



spacer  
640113 (13mm red)  
640114 (14mm yellow)

180x45  
TRANSOM  
104mm  
bonding of pane

Sprosse  
traverse  
traverso  
travesañ  
Round-line

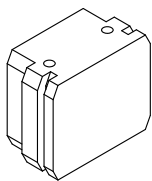
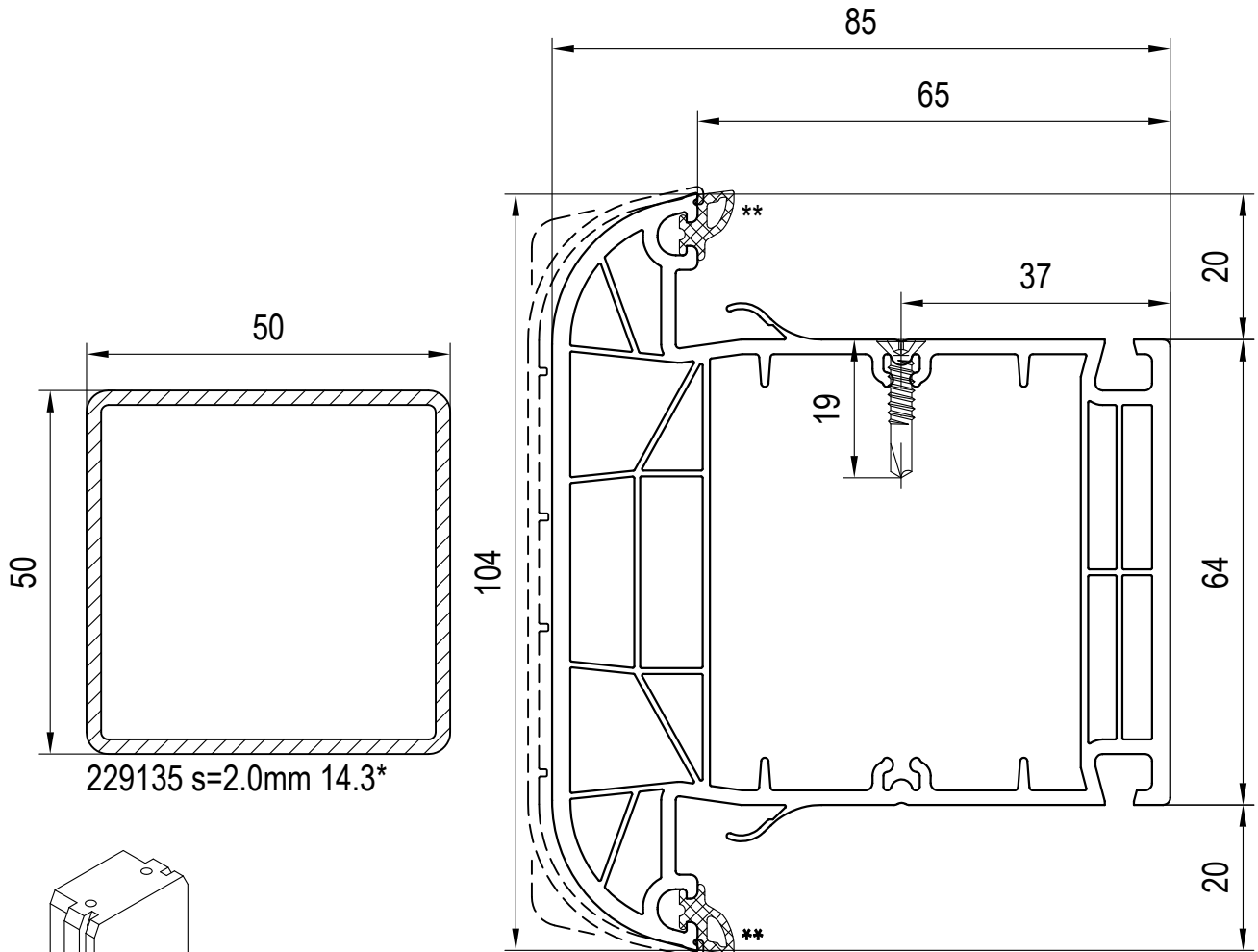

transom connector, uPVC  
685145 without sticks

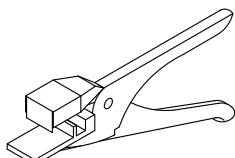

640940 gasket scissors  
for transoms  
with pre-inserted gaskets

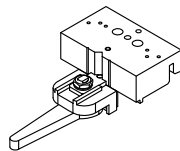

680900 drilling jig  
-> 657130 / 030 mullion connector  
-> 657134 / 034 cross connector  
-> 180x45 transom

289443 aluminium shell (RL)

289343 aluminium shell (CL)

Fix reinforcement in the profile with self-drilling  
window screws, e.g.: FD21 3.9 x 19mm.

Seal screw heads in the horizontal bottom rebate.

\* Ix-value in cm<sup>4</sup>

\*\* Gasket(s) inserted in factory: see current price list

May be subject to change  
and errors excepted!

scale: 1:1  
02\_D\_01\_8\*

Main Profiles: Mullions / Transoms  
Bonding of Pane, Transom, 104mm: 180x45

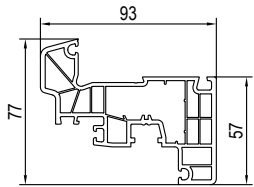

180x26 compatible sash (CL)

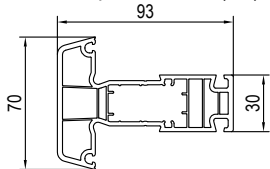

180x47 compatible transom (CL)

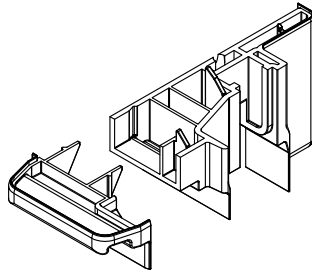

680029 false mullion end cap set

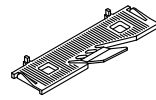

620301 compensating block

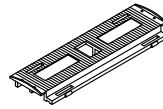

620305 compensating block with integrated 5mm-spacer (only for glazing <24mm)

180x69  
**FALSE MULLION SASH**  
semi-recessed 87mm  
extended rebate

Stulpflügel  
battement intégré  
anta-scambio battuta  
hoja batiente  
**Classic-line**

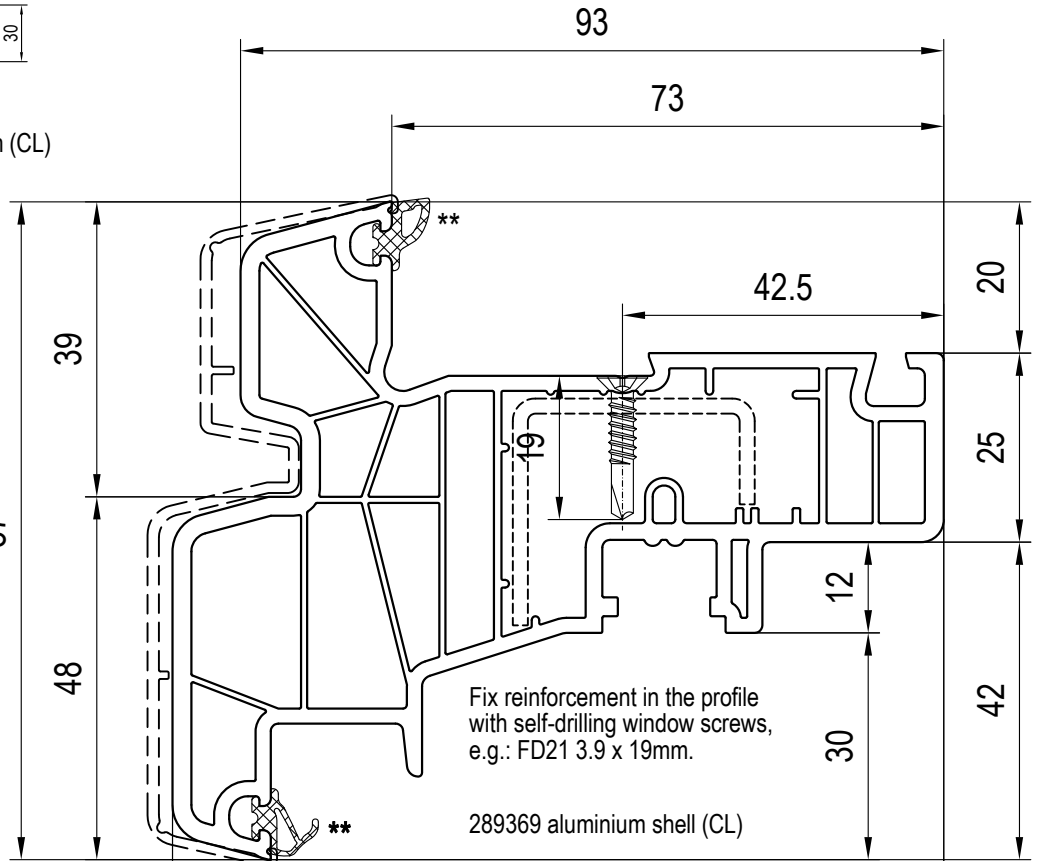

239019 s=1.5mm 1.6\*  
239020 s=2.0mm 2.1\*

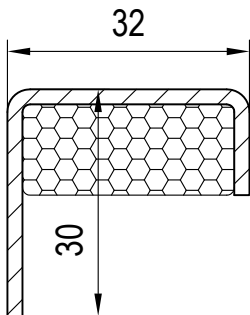

250102 s=2.0mm 2.1\*

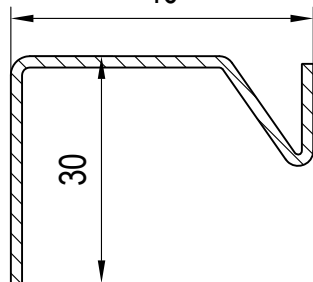

259025 s=1.5mm 3.1\*

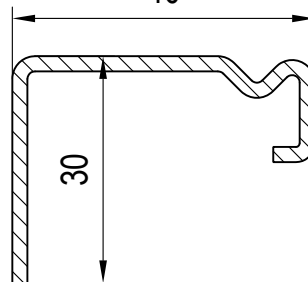

259002 s=2.0mm 3.9\*

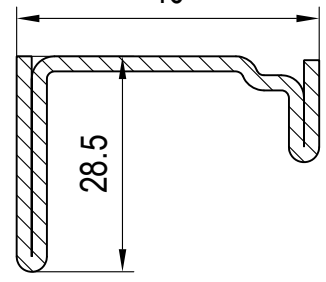

249025 s=2.0mm 5.1\*

\* Ix-value in cm<sup>4</sup>

\*\* Gasket(s) inserted in factory: see current price list.

May be subject to change and errors excepted!

scale: 1:1  
02\_E\_01\_8\*

**Main Profiles: False Mullion Sash / False Mullion Profiles**  
Extended Rebate, False Mullion Sash, Semi-Recessed. 87mm: 180x69



447340, 449340  
gasket

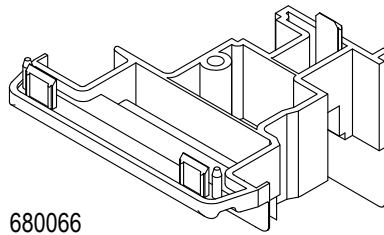

680066  
false mullion end cap

180x66  
FALSE MULLION  
84mm

Stulp  
battement  
scambio battuta  
batiente  
Classic-line

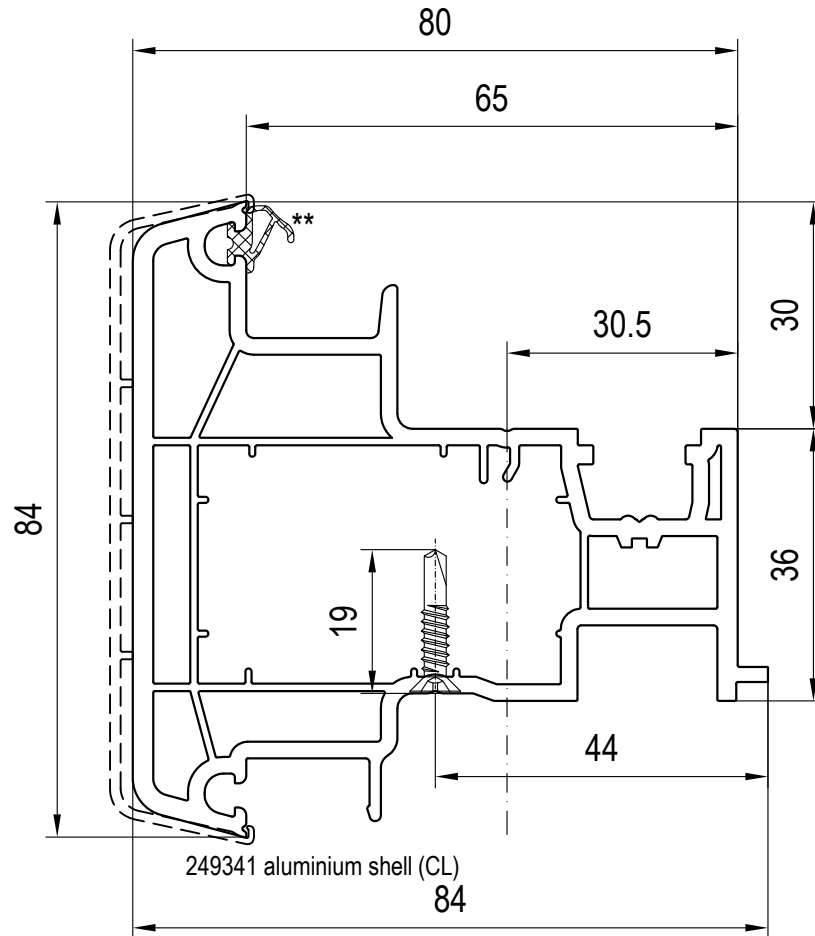

Fix reinforcement in the profile with self-drilling window screws, e.g.: FD21 3.9 x 19mm or screw completely.

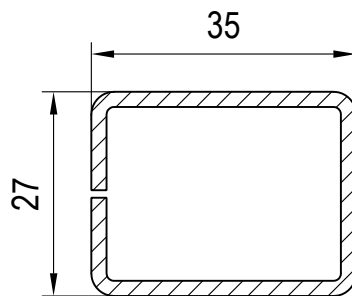

229029 s=1.25mm 2.4\*  
229030 s=2.0mm 3.6\*

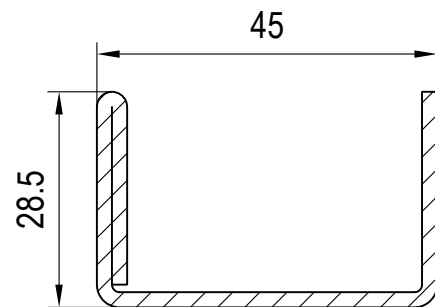

289066 s=2.0mm 7.7\*

\* Ix-value in cm<sup>4</sup>

\*\* Gasket(s) inserted in factory: see current price list.

May be subject to change  
and errors excepted!

scale: 1:1  
02\_E\_01\_8\*

**Main Profiles: False Mullion Sash / False Mullion Profiles**  
**False Mullion, 84mm: 180x66**



447340, 449340  
gasket

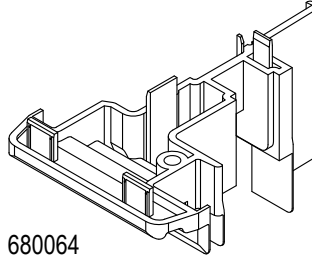

680064  
false mullion end cap

180x64  
FALSE MULLION  
64mm

Stulp  
battement  
scambio battuta  
batiente  
Classic-line

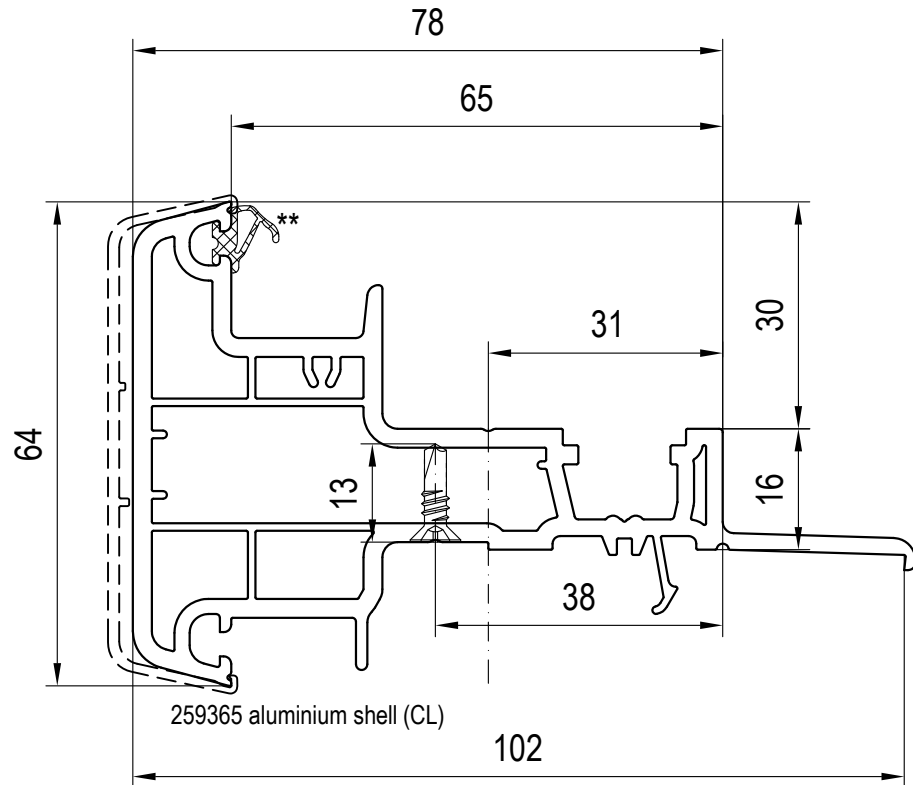

Fix reinforcement in the profile with self-drilling window screws, e.g.: FDM2 M4 x 13mm or screw completely.

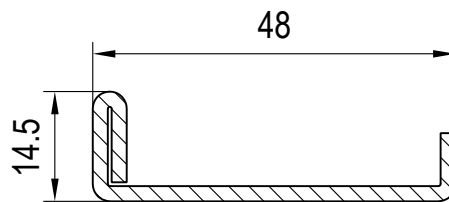

229063 s=2.0mm 4.3\*

\* Ix-value in cm<sup>4</sup>

\*\* Gasket(s) inserted in factory: see current price list.

May be subject to change  
and errors excepted!

scale: 1:1  
02\_E\_01\_8\*

**Main Profiles: False Mullion Sash / False Mullion Profiles**  
**False Mullion, 64mm: 180x64**



447340, 449340  
gasket

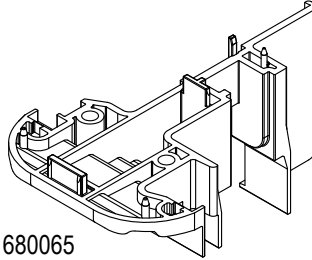

680065  
false mullion end cap

180x65  
FALSE MULLION  
64mm

Stulp  
battement  
scambio battuta  
batiente  
Round-line

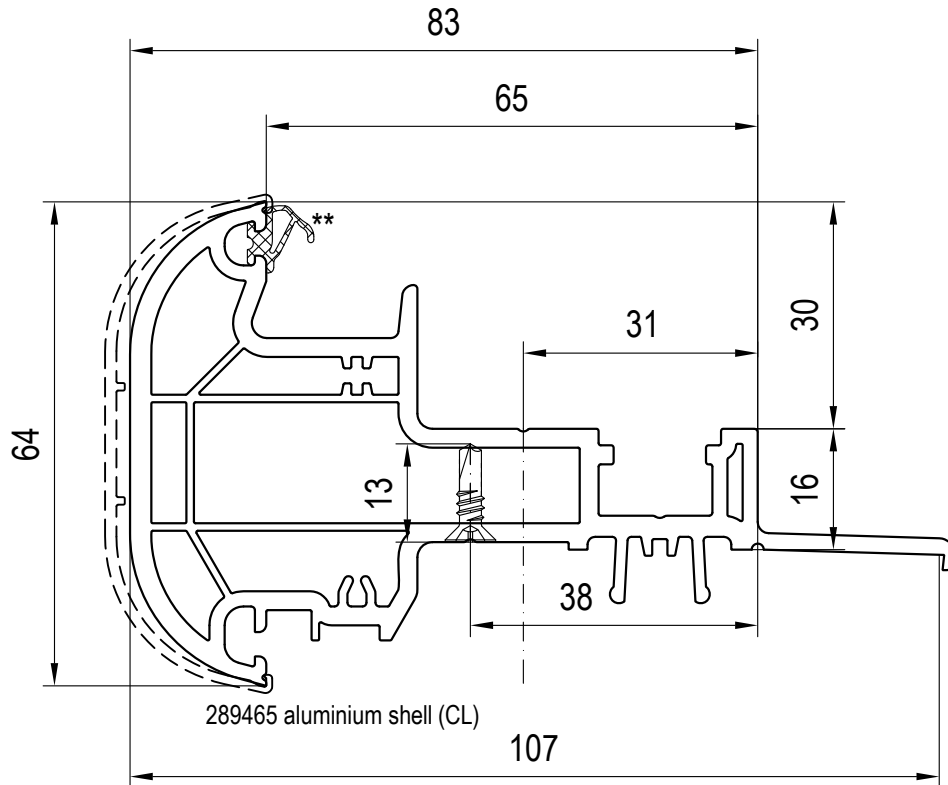

Fix reinforcement in the profile with self-drilling window screws, e.g.: FDM2 M4 x 13mm or screw completely.

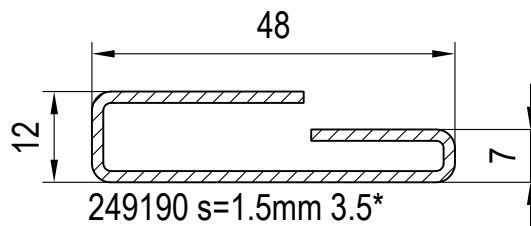

\* Ix-value in cm<sup>4</sup>

\*\* Gasket(s) inserted in factory: see current price list.

May be subject to change  
and errors excepted!

scale: 1:1  
02\_E\_01\_8\*

**Main Profiles: False Mullion Sash / False Mullion Profiles**  
**False Mullion, 64mm: 180x65**

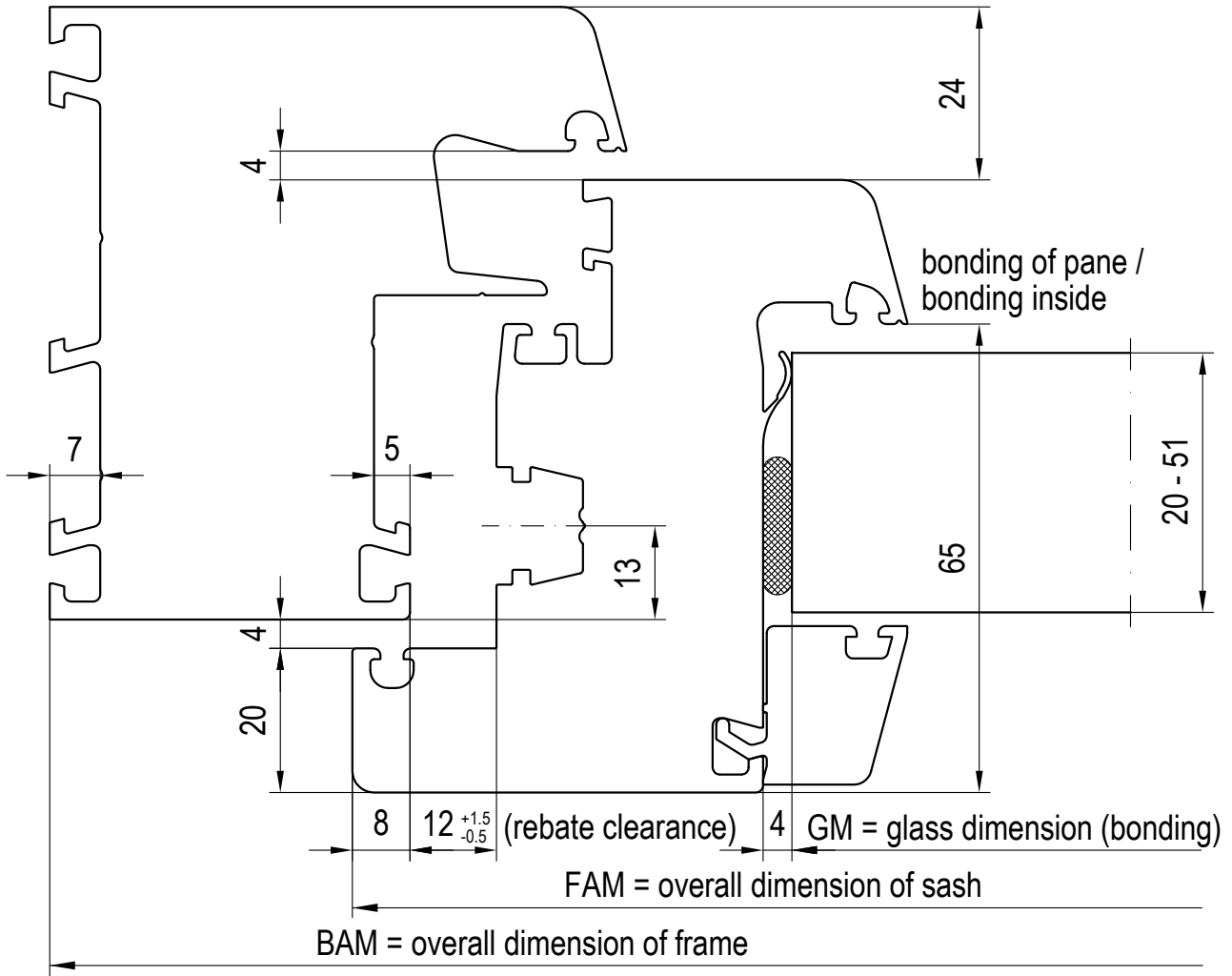

+8mm extended rebate: 28 - 59

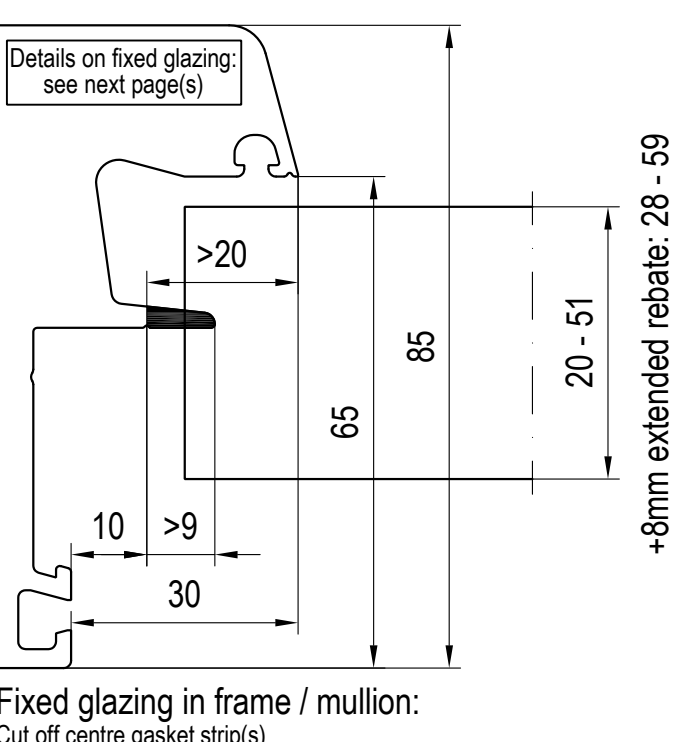

Fixed glazing in frame / mullion:  
Cut off centre gasket strip(s)

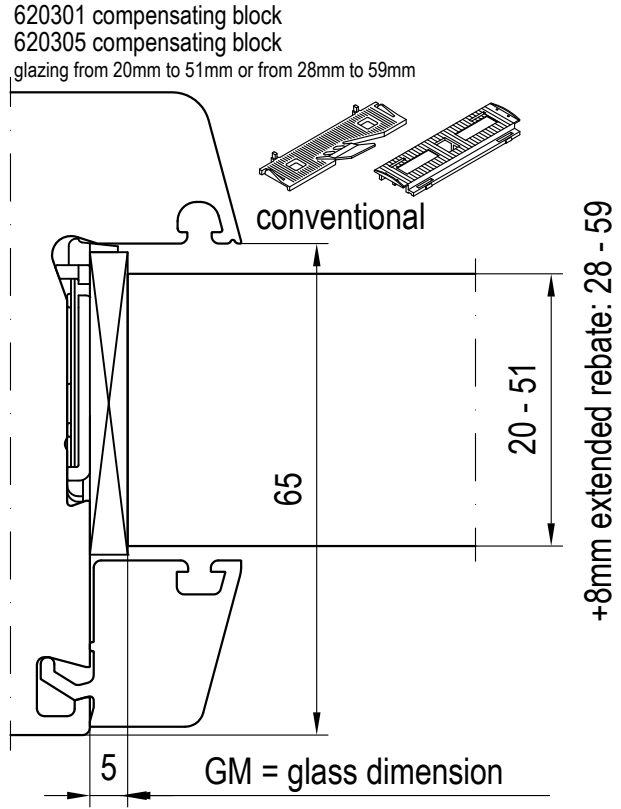

GM = glass dimension

## Construction Dimensions

May be subject to change and errors excepted!  
scale: 1:1  
03\_A\_01\_8\*

680016 compensating block  
glazing from 34mm to 49mm  
(depends on glazing bead design and gaskets)

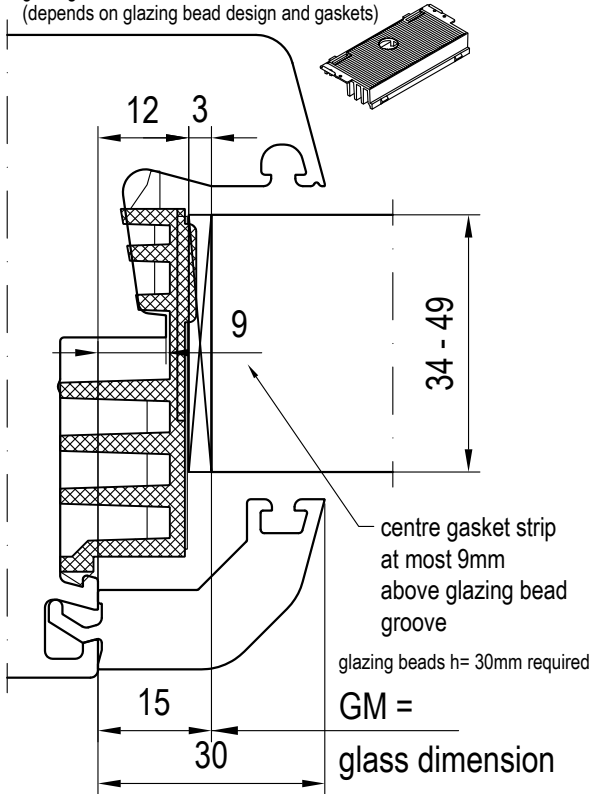

650018 compensating block  
+ 650019 extension  
glazing from 20mm to 26mm  
(depends on glazing bead design and gaskets)

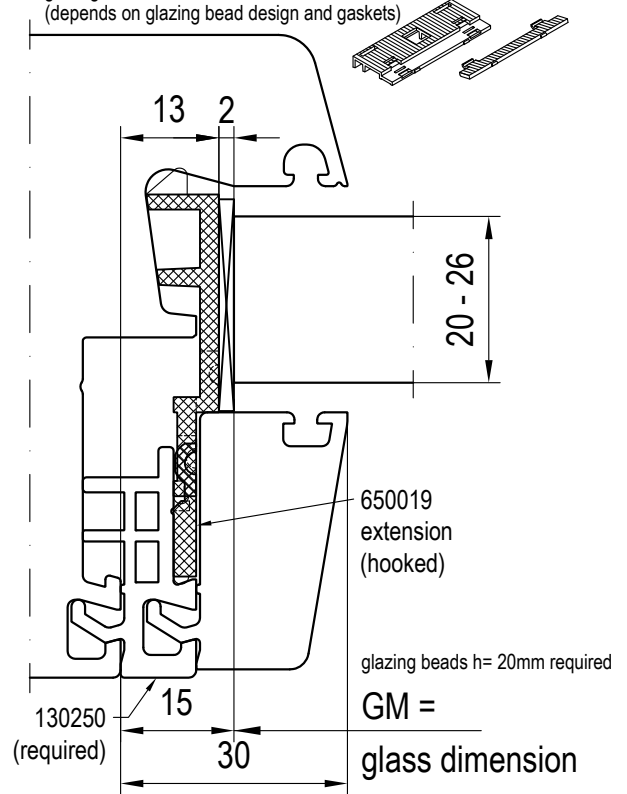

650018 compensating block  
+ 2x 650019 extension  
glazing from 24mm to 45mm  
(depends on glazing bead design and gaskets)

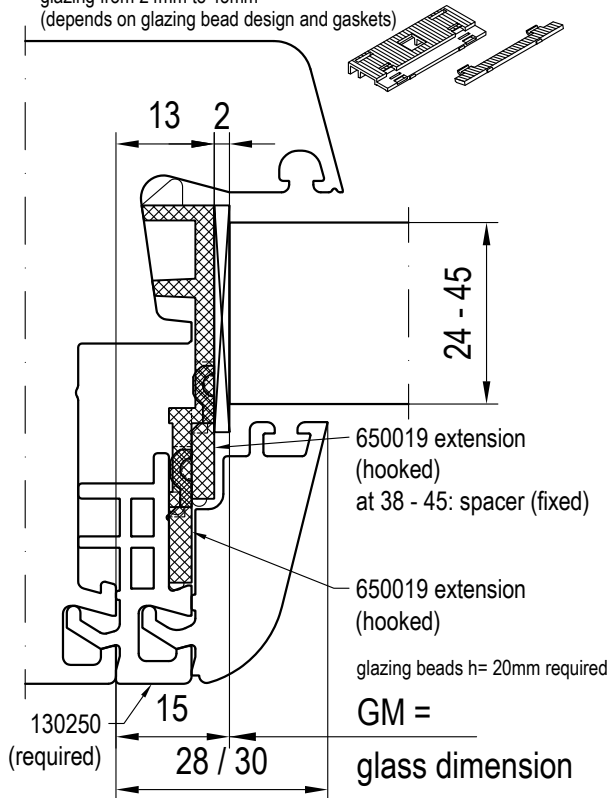

650018 compensating block  
+ 669899 spacer (3x22x100)  
glazing from 30mm to 51mm  
(depends on glazing bead design and gaskets)

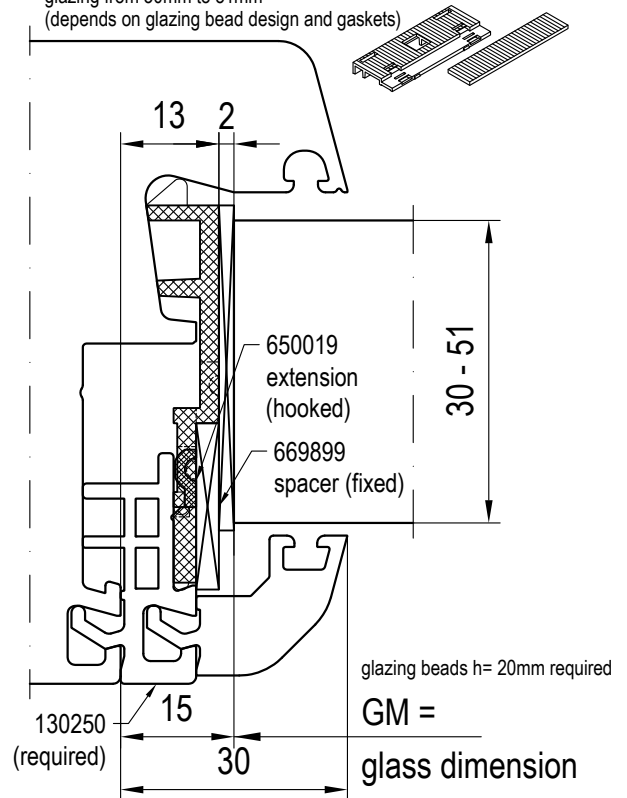

May be subject to change  
and errors excepted!

scale: 1:1  
03\_A\_01\_8\*

Construction Dimensions  
Fixed Glazing in Frame / Mullion

650018 compensating block  
+ 650019 (depends on glazing bead design and gaskets)  
glazing from 32mm to 36mm  
(depends on glazing bead design and gaskets)

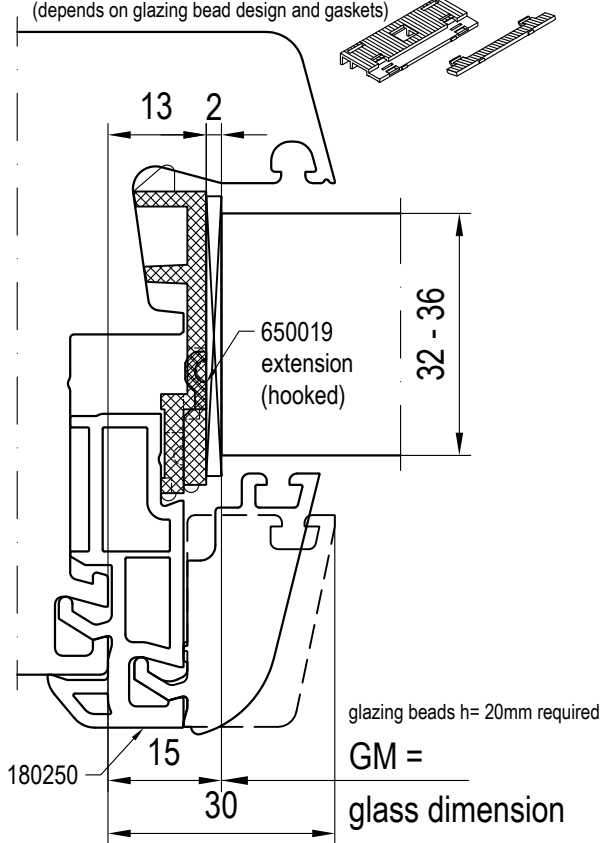

650018 compensating block  
+ 669899 spacer (3x22x100)  
glazing from 36mm to 48mm  
(depends on glazing bead design and gaskets)

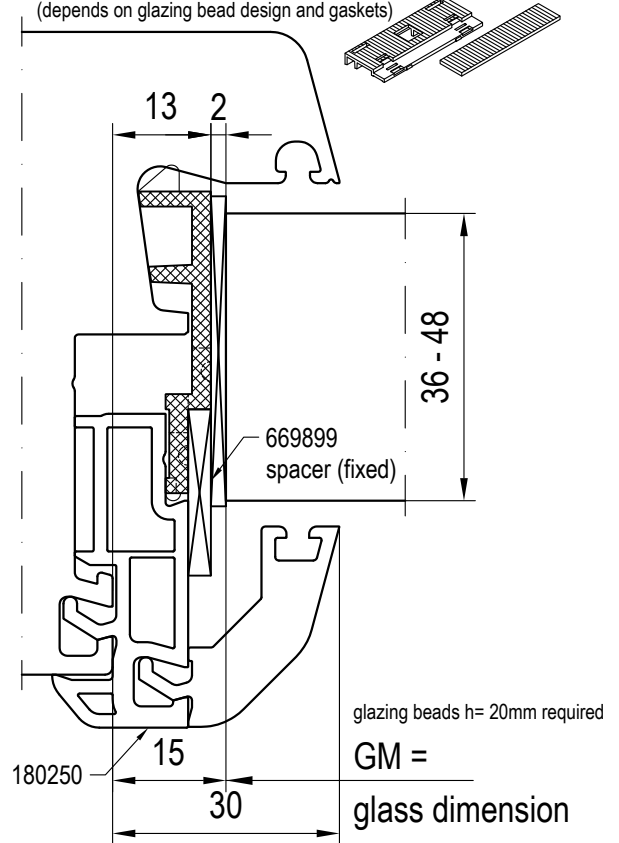

650018 compensating block + 660902 spacer (3x30x100)  
glazing from 36mm to 56mm  
(depends on glazing bead design and gaskets)

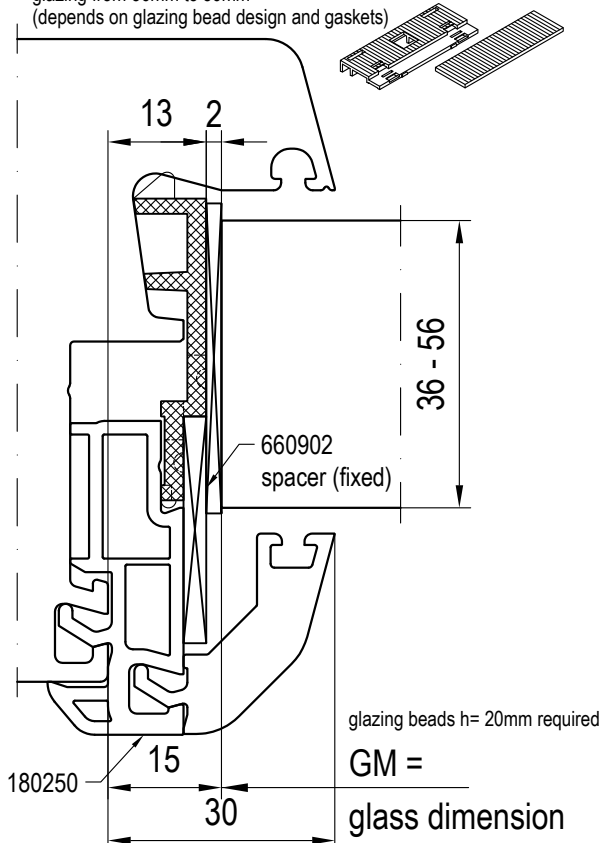

650018 compensating block + 659936 spacer (3x34x100)  
glazing from 57mm to 58/59mm  
(depends on glazing bead design and gaskets)

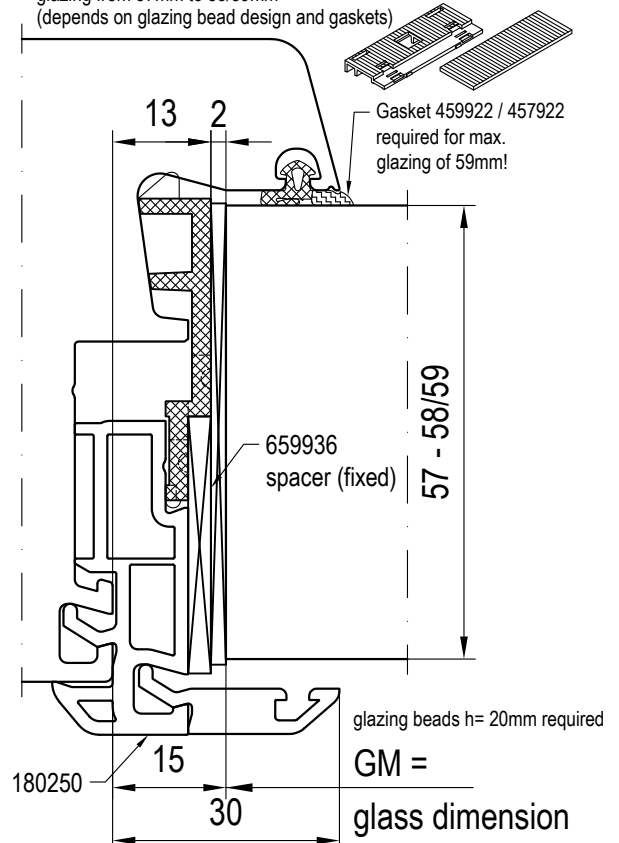

May be subject to change  
and errors excepted!

scale: 1:1  
03\_A\_01\_8\*

**Rebate Extension +8mm**

**Construction Dimensions  
Fixed Glazing in Frame / Mullion**



top: frame - sash

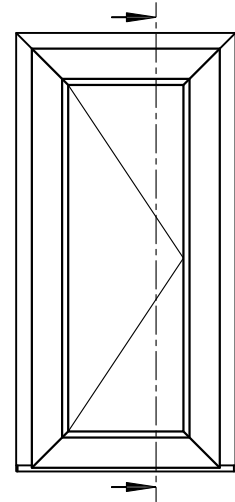
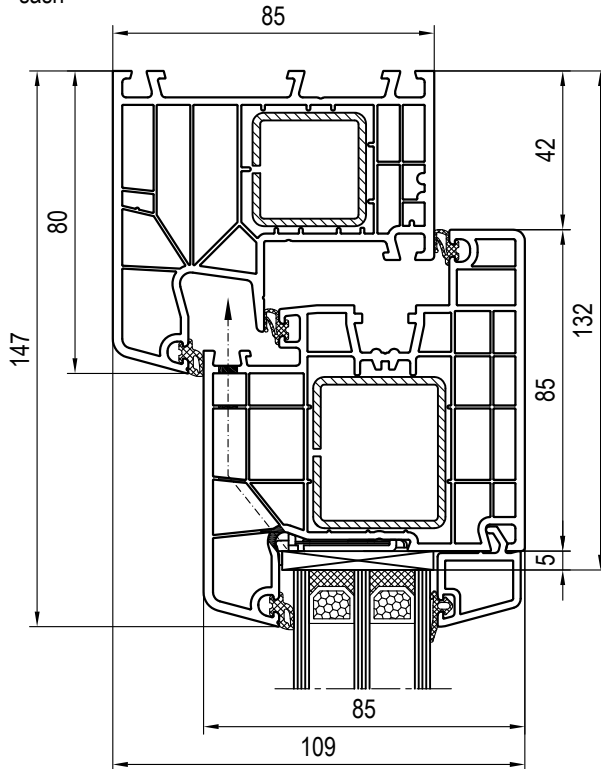

- 180x05 - 180x30 - 120636 / 120666 Classic-line
- 080x05 - 180x30 - 120636 / 120666 no drawing: Classic-line
- 180x03 - 180x32 - 120650 / 120680 no drawing: Round-line
- ... - 180x31 - 120636 / 120666 no drawing: Classic-line, opening outwards

bottom: threshold - sash  
-> 499910, 156252, 247052

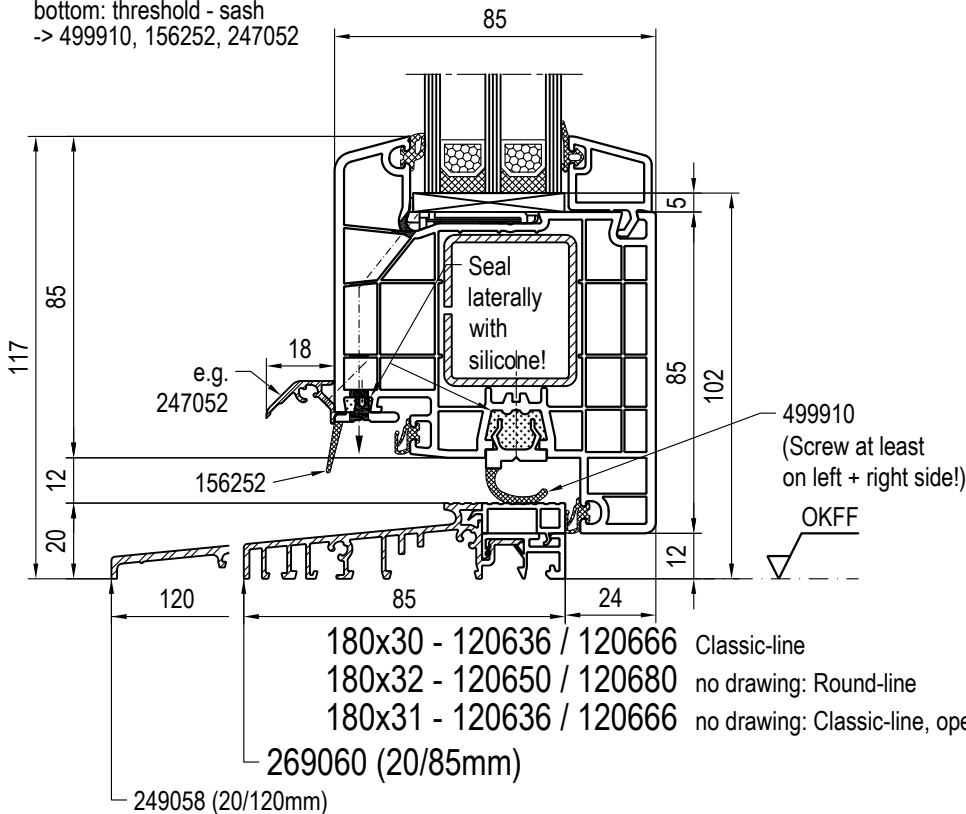

- 180x30 - 120636 / 120666 Classic-line
- 180x32 - 120650 / 120680 no drawing: Round-line
- 180x31 - 120636 / 120666 no drawing: Classic-line, opening outwards

269060 (20/85mm)

249058 (20/120mm)

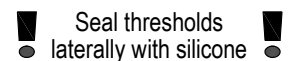

May be subject to change and errors excepted!

scale: 1:2  
03\_B\_01\_8\*

## Balcony/Side Entrance Doors / Threshold Combinations

### Threshold - Sash - Frame

top: frame - sash

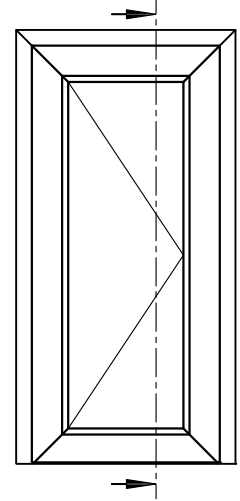
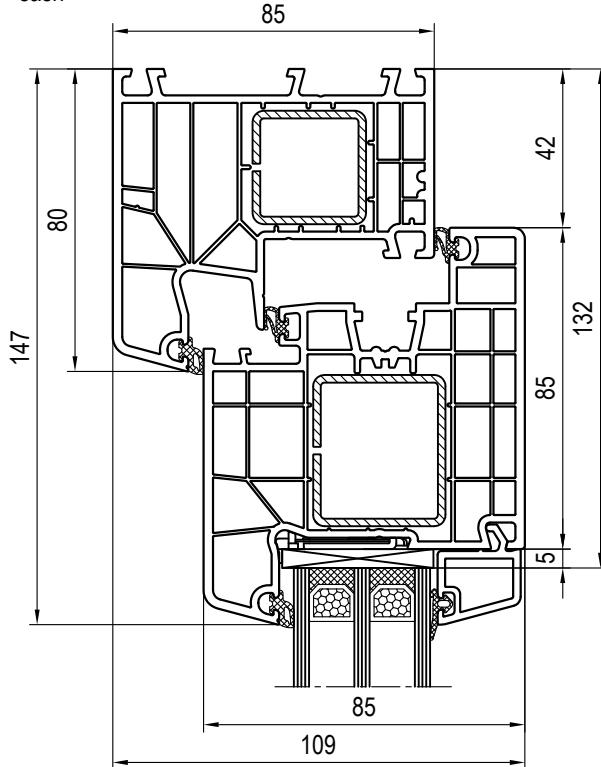

- 180x05 - 180x30 - 120636 / 120666 Classic-line
- 080x05 - 180x30 - 120636 / 120666 no drawing: Classic-line
- 180x03 - 180x32 - 120650 / 120680 no drawing: Round-line
- ... - 180x31 - 120636 / 120666 no drawing: Classic-line, opening outwards

flat threshold

bottom: threshold - sash

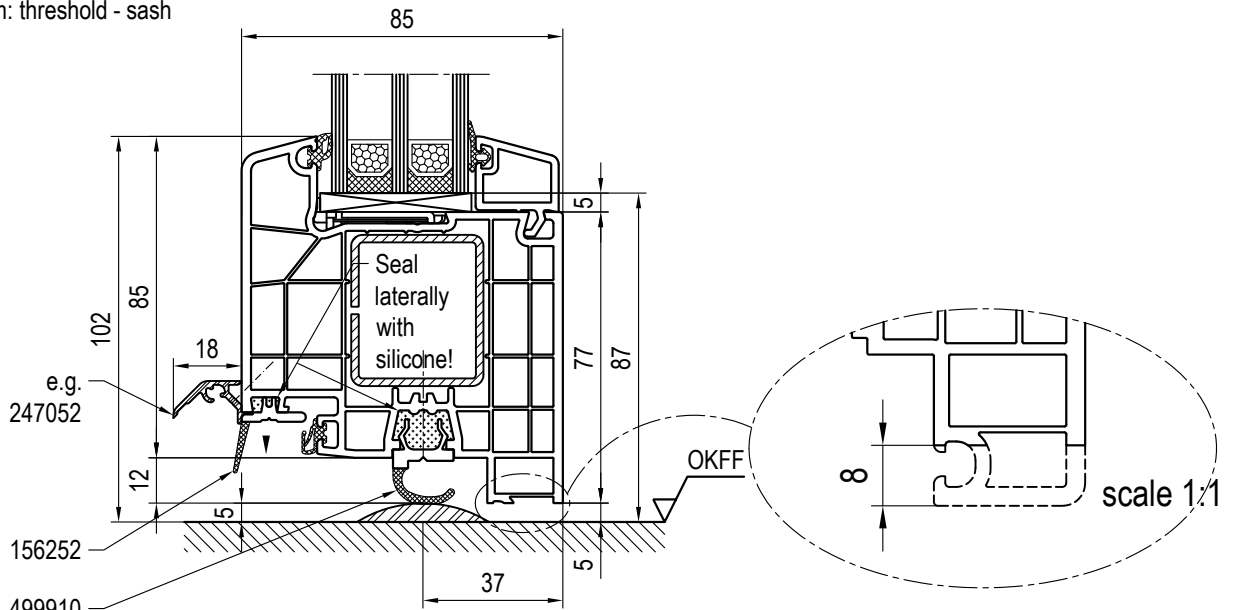

(Screw at least on left + right side)

- 180x30 - 120636 / 120666 Classic-line
- 180x32 - 120650 / 120680 no drawing: Round-line
- 180x31 - 120636 / 120666 no drawing: Classic-line, opening outwards

in the interior room only

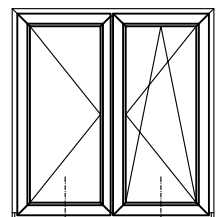
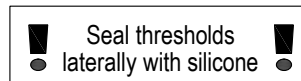
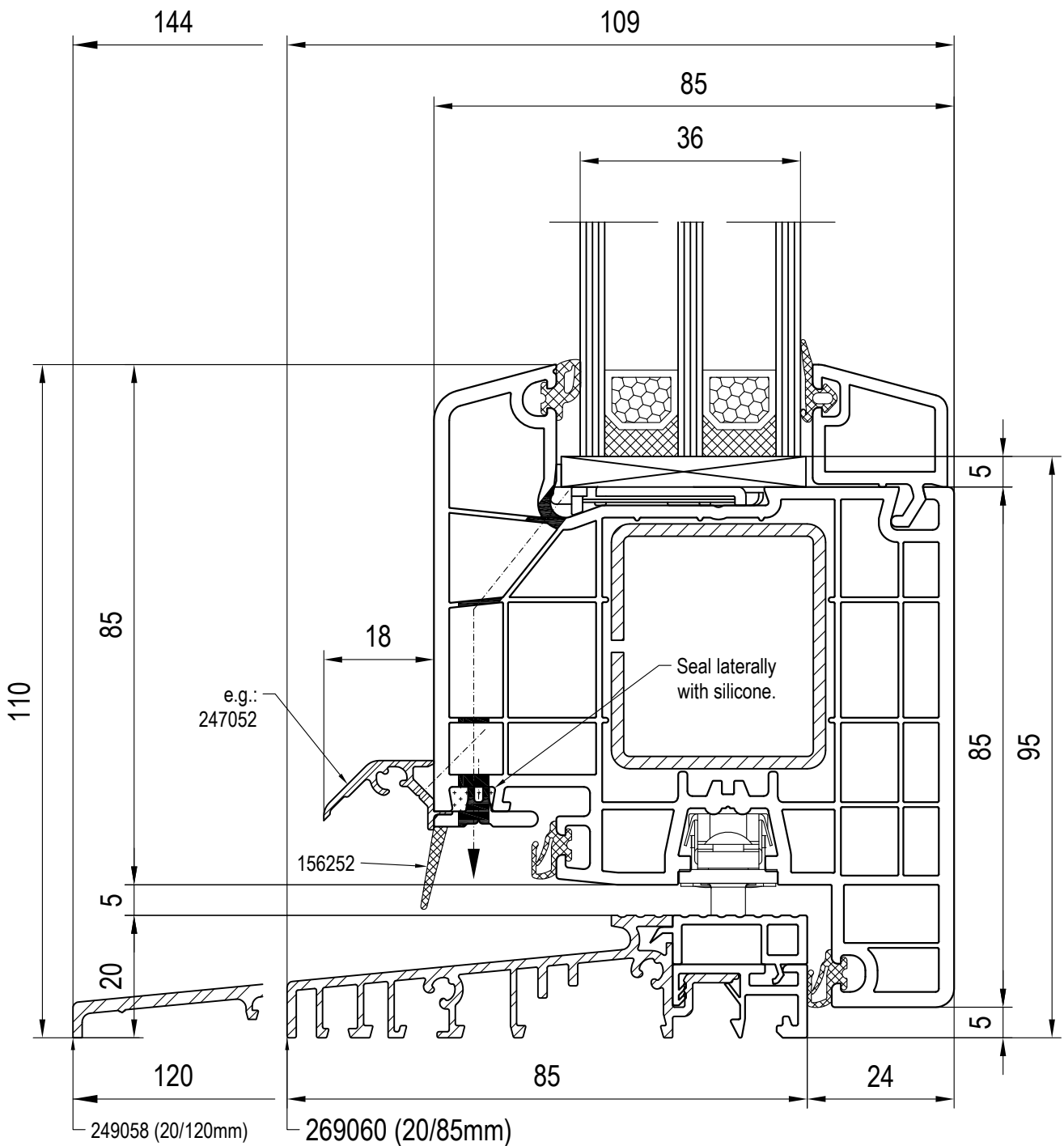

May be subject to change and errors excepted!

scale: 1:1  
03\_C\_01\_8\*



Tilt-and-Turn Door Thresholds

Glazing Bead 120636 / 120666

Tilt-and-Turn Door Thresholds

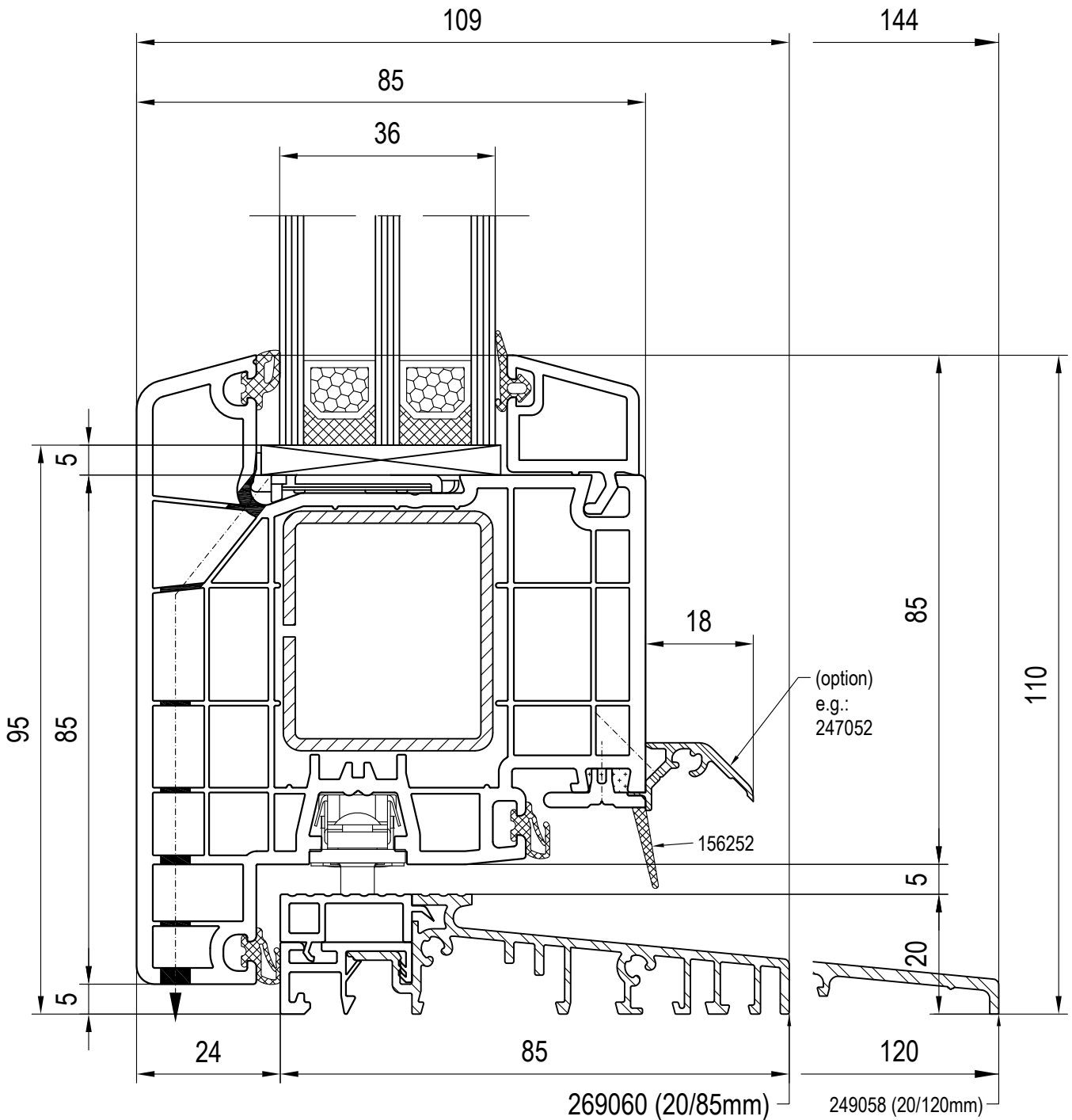
Sash 180x30



 Seal thresholds  
 laterally with silicone

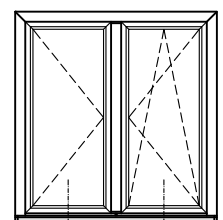

May be subject to change and errors excepted!

scale: 1:1  
03\_C\_01\_8\*



Tilt-and-Turn Door Thresholds

Glazing Bead 120636 / 120666

Tilt-and-Turn Door Thresholds

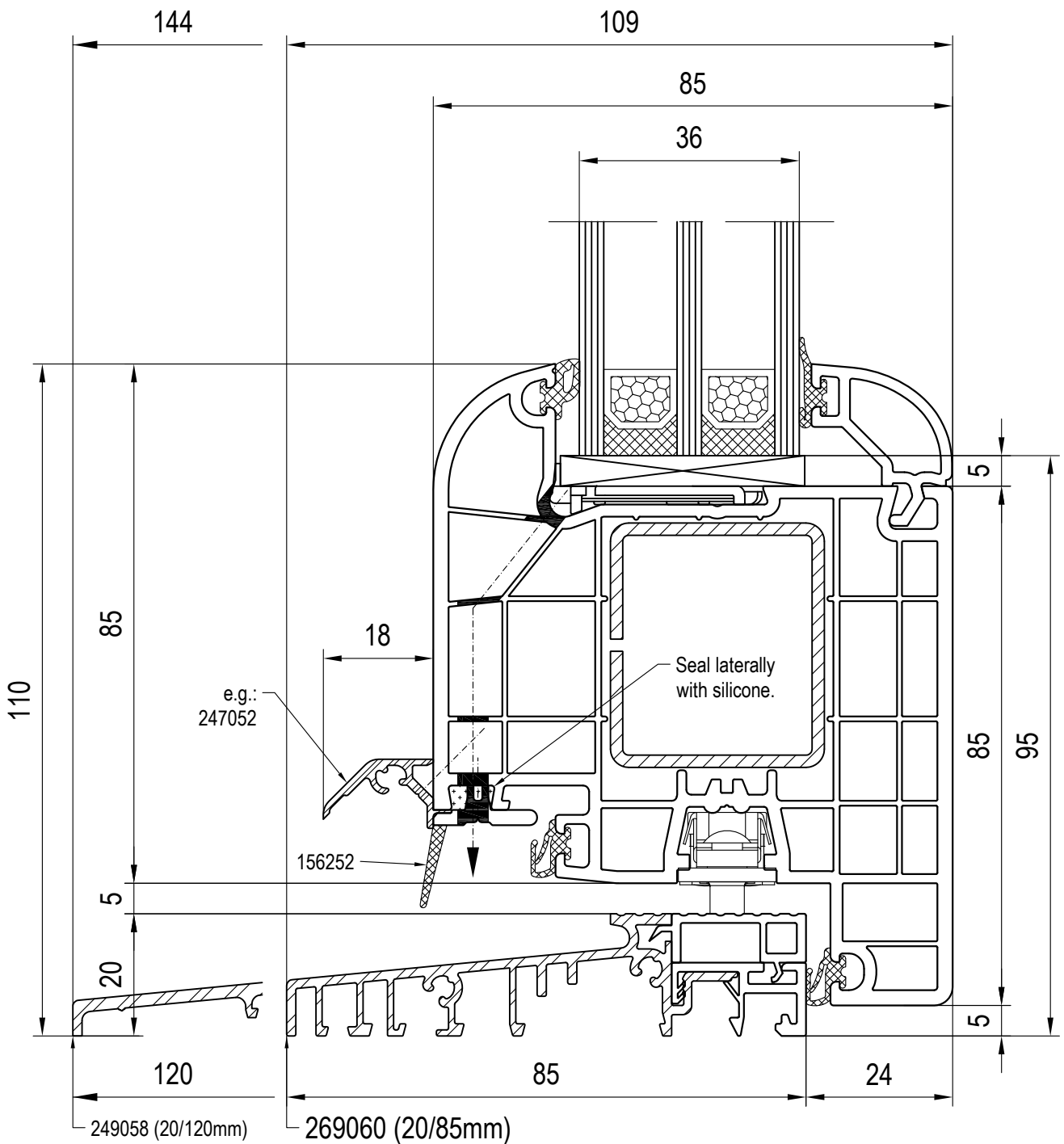
Sash 180x31



 Seal thresholds  
 laterally with silicone 

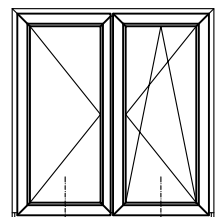

May be subject to change and errors excepted!

scale: 1:1  
03\_C\_01\_8\*

Tilt-and-Turn Door Thresholds

Glazing Bead 120650 / 120680

Tilt-and-Turn Door Thresholds

Sash 180x32

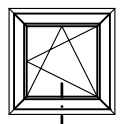
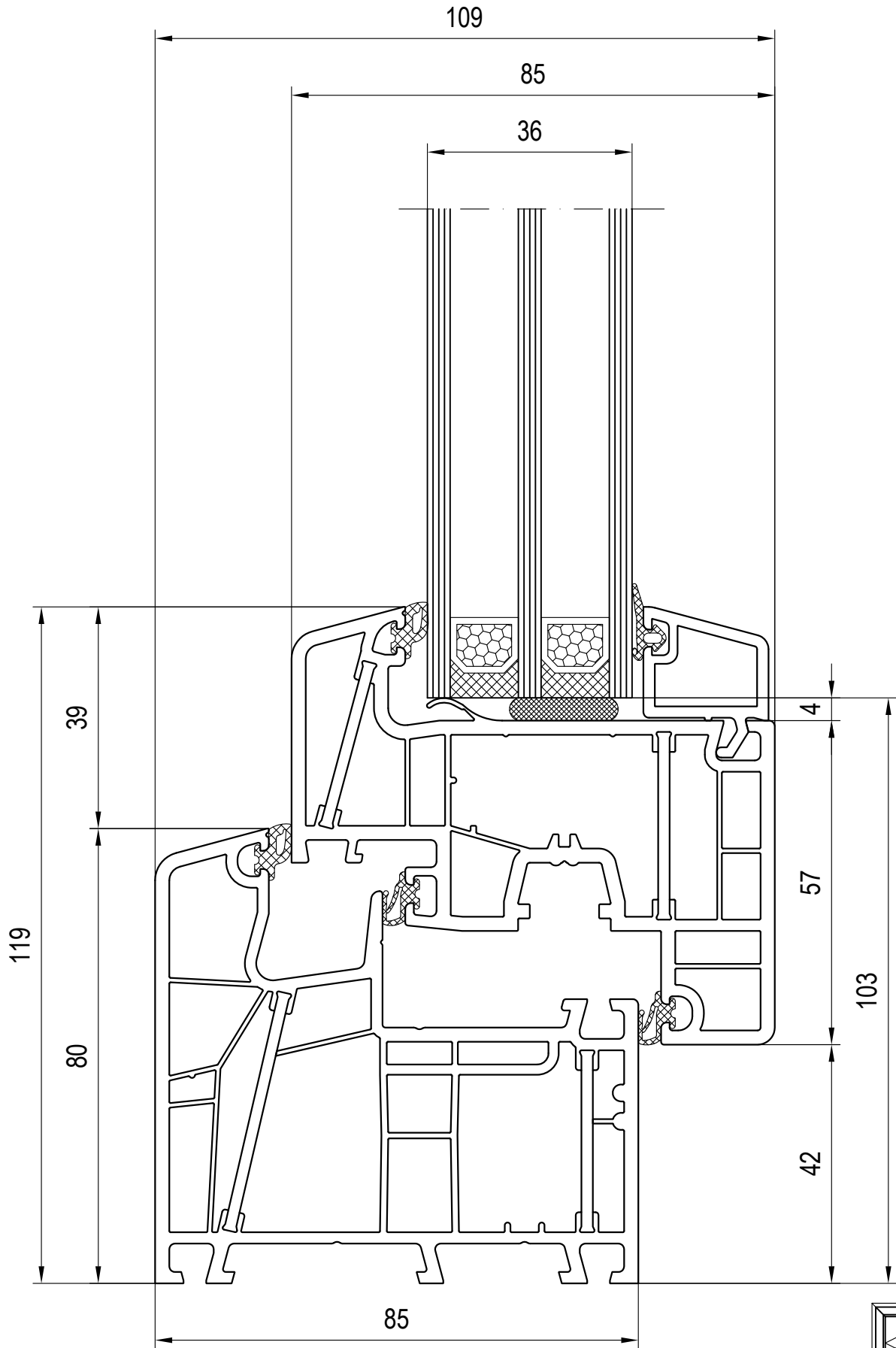

May be subject to change  
 and errors excepted!  
 scale: 1:1  
 03\_D\_01\_8\*

Combinations: Frame - Sash  
 Glazing Bead 120636/120666

Frame 080x05  
 Sash 080x86

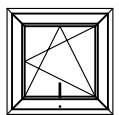
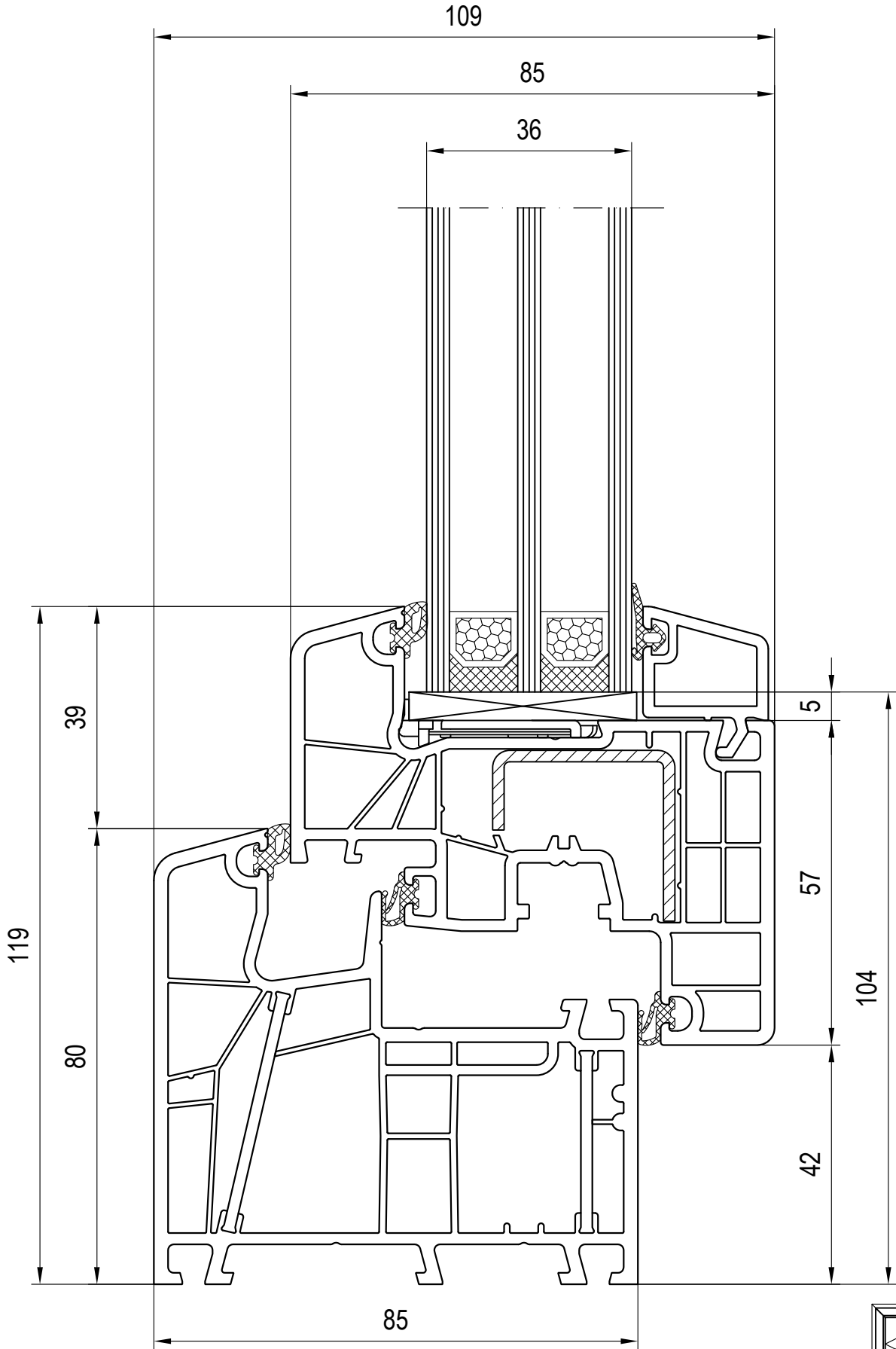

May be subject to change and errors excepted!

scale: 1:1  
03\_D\_01\_8\*

Combinations: Frame - Sash  
Glazing Bead 120636/120666

Frame 080x05  
Sash 180x20

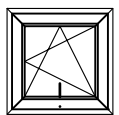
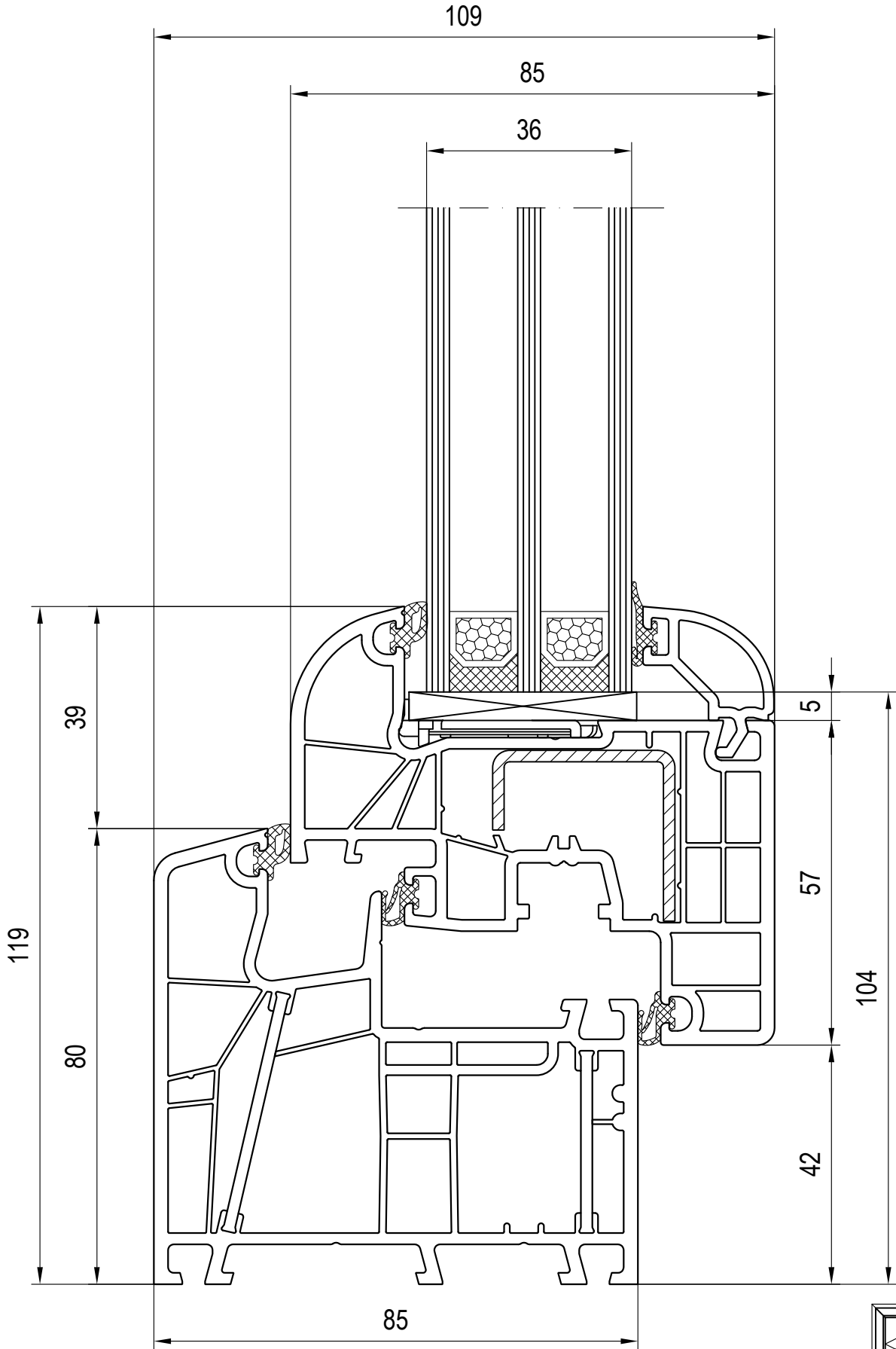

May be subject to change  
 and errors excepted!

scale: 1:1  
 03\_D\_01\_8\*

Combinations: Frame - Sash  
 Glazing Bead 120650/120680

Frame 080x05  
 Sash 180x22



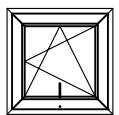
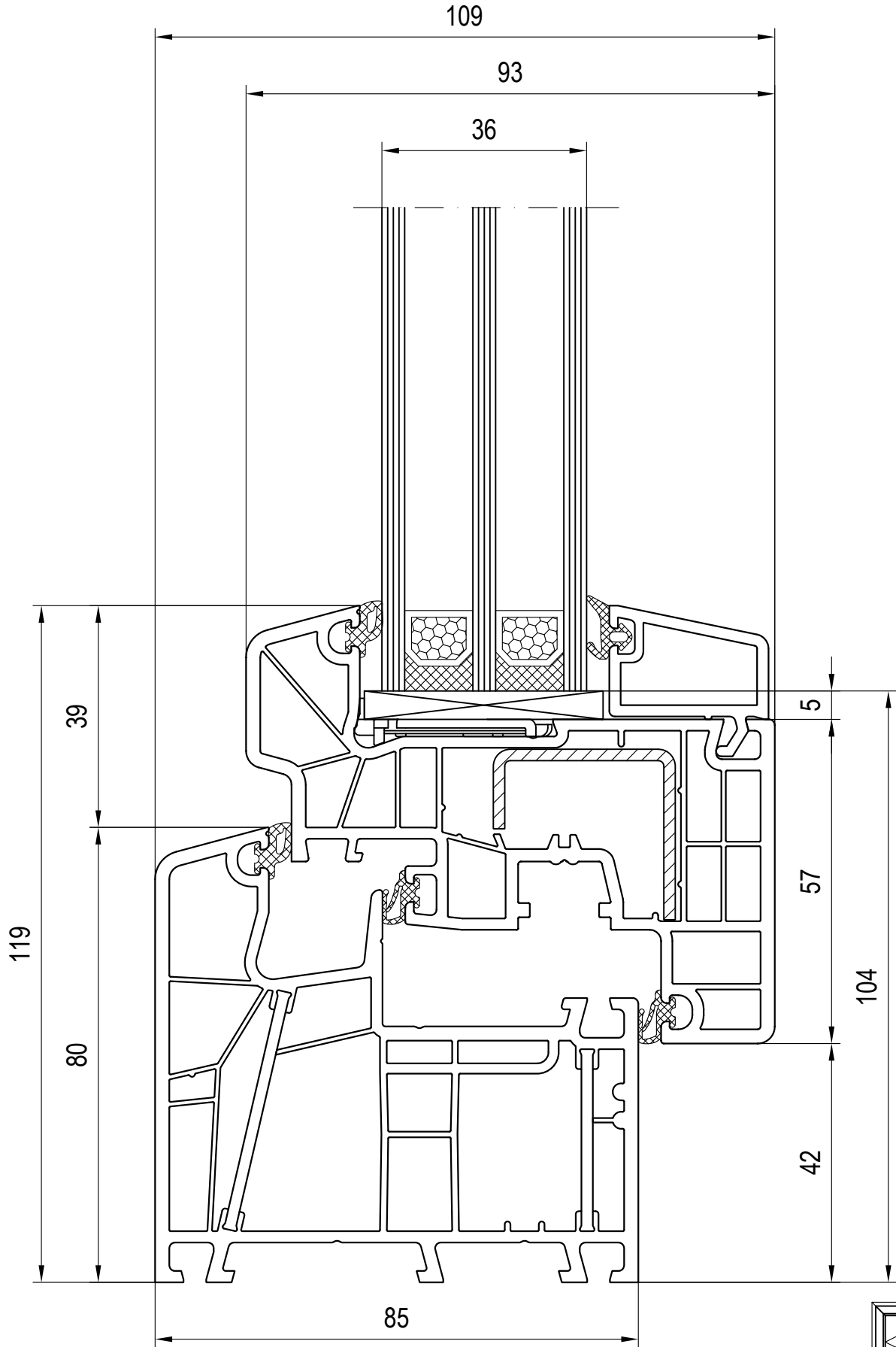

May be subject to change  
and errors excepted!

scale: 1:1  
03\_D\_01\_8\*

Combinations: Frame - Sash  
Glazing Bead 120838/120868

Frame 080x05  
Sash 180x26

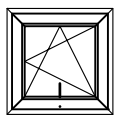
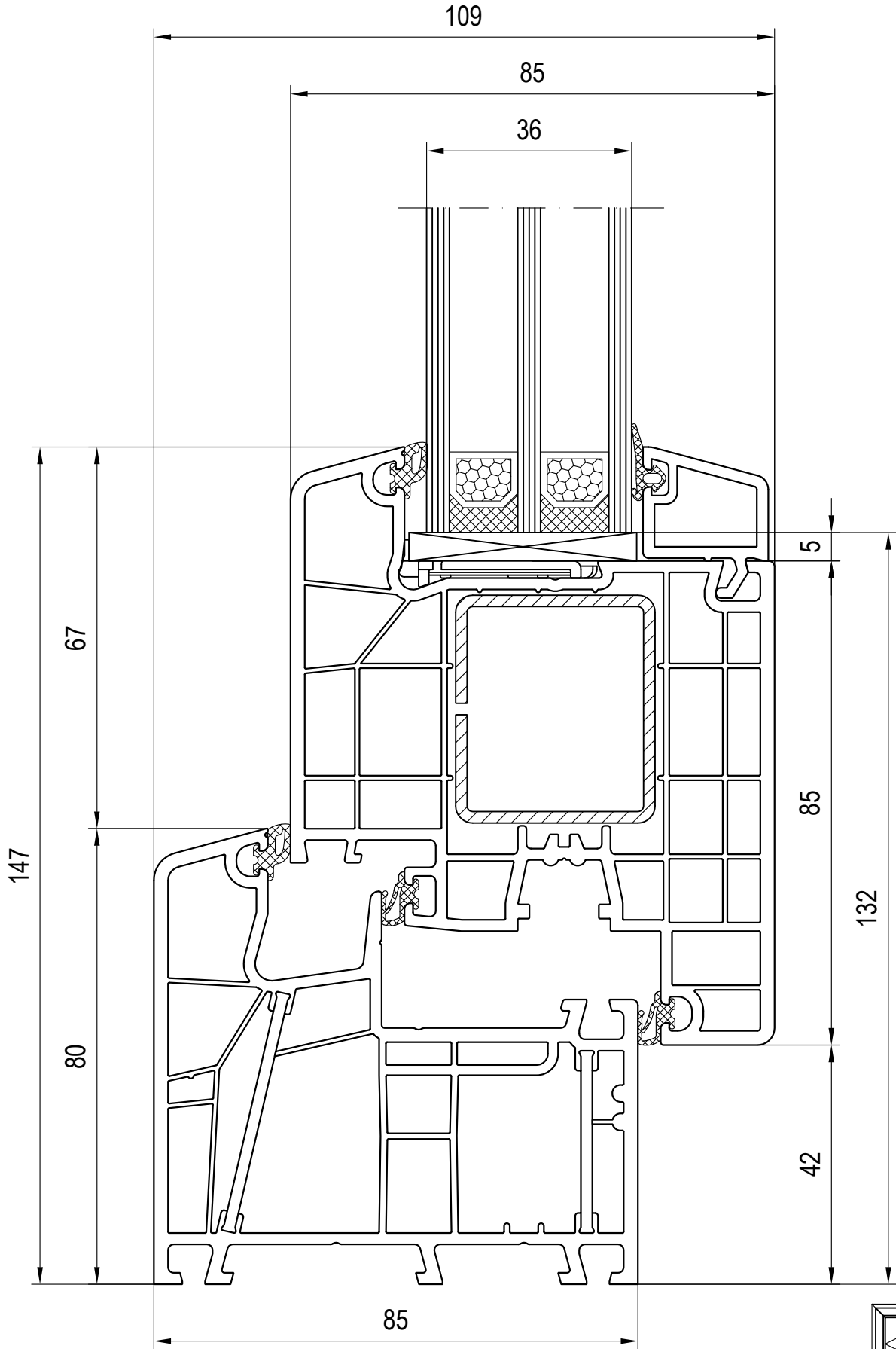

May be subject to change and errors excepted!

scale: 1:1  
03\_D\_01\_8\*

Combinations: Frame - Sash  
Glazing Bead 120636/120666

Frame 080x05  
Sash 180x30

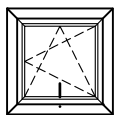
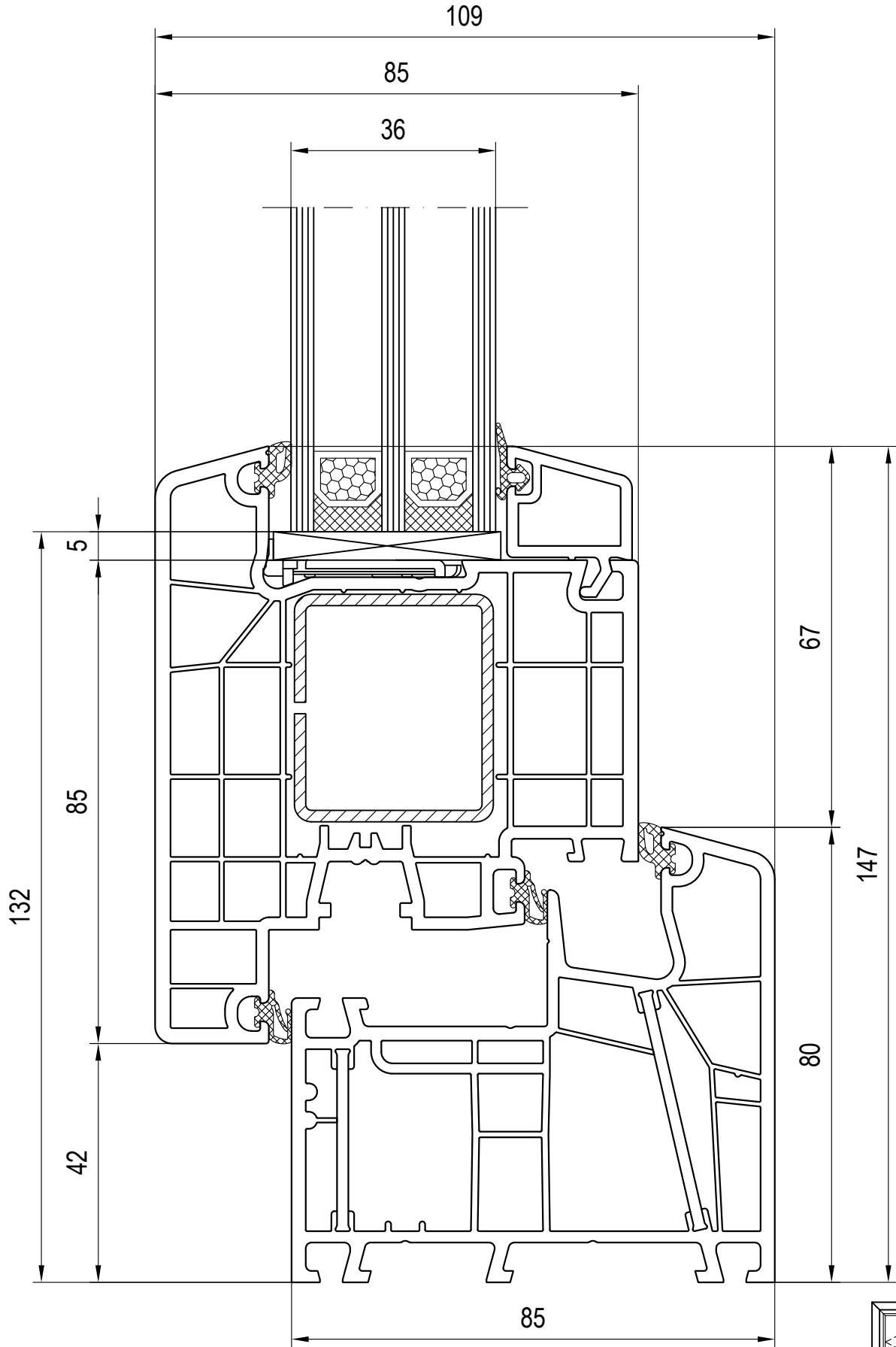

May be subject to change  
 and errors excepted!

scale: 1:1  
 03\_D\_01\_8\*

Combinations: Frame - Sash  
 Glazing Bead 120636/120666

Frame 080x05  
 Sash 180x31

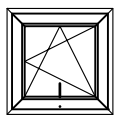
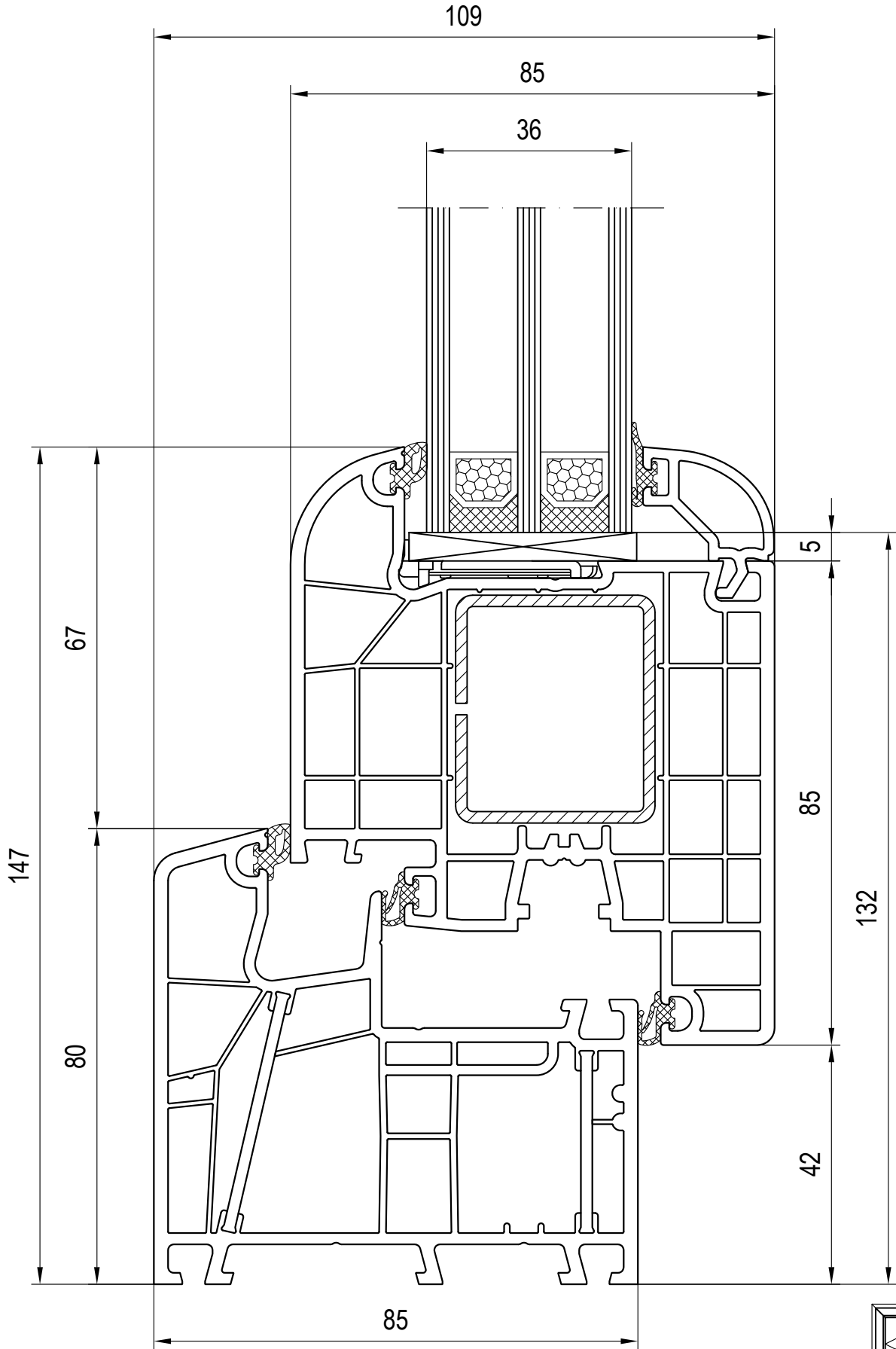

May be subject to change  
and errors excepted!

scale: 1:1  
03\_D\_01\_8\*

Combinations: Frame - Sash  
Glazing Bead 120650/120680

Frame 080x05  
Sash 180x32

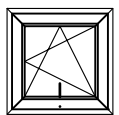
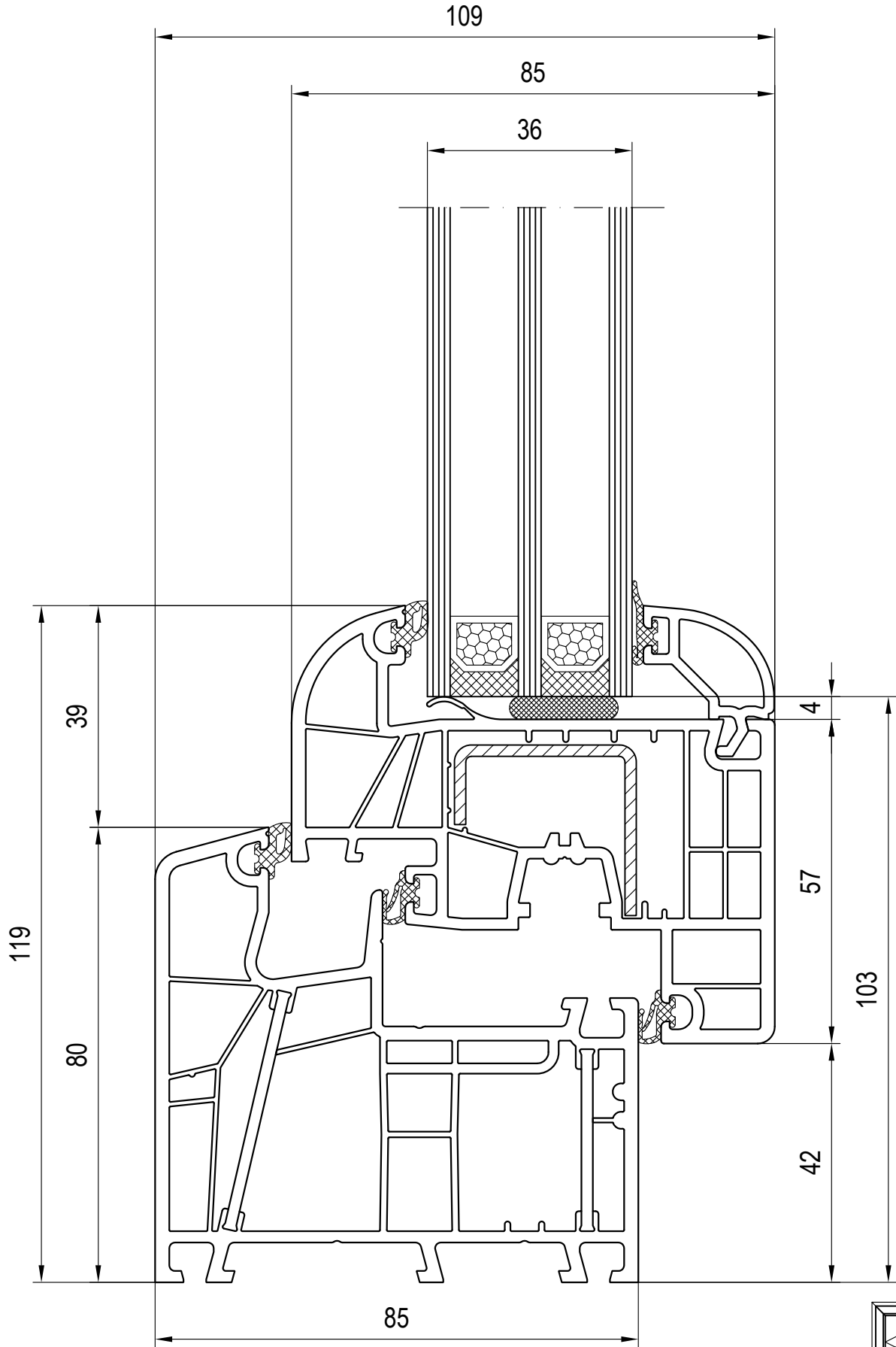

May be subject to change  
 and errors excepted!

scale: 1:1  
 03\_D\_01\_8\*

Combinations: Frame - Sash  
 Glazing Bead 120650/120680

Frame 080x05  
 Sash 180x83

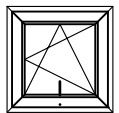
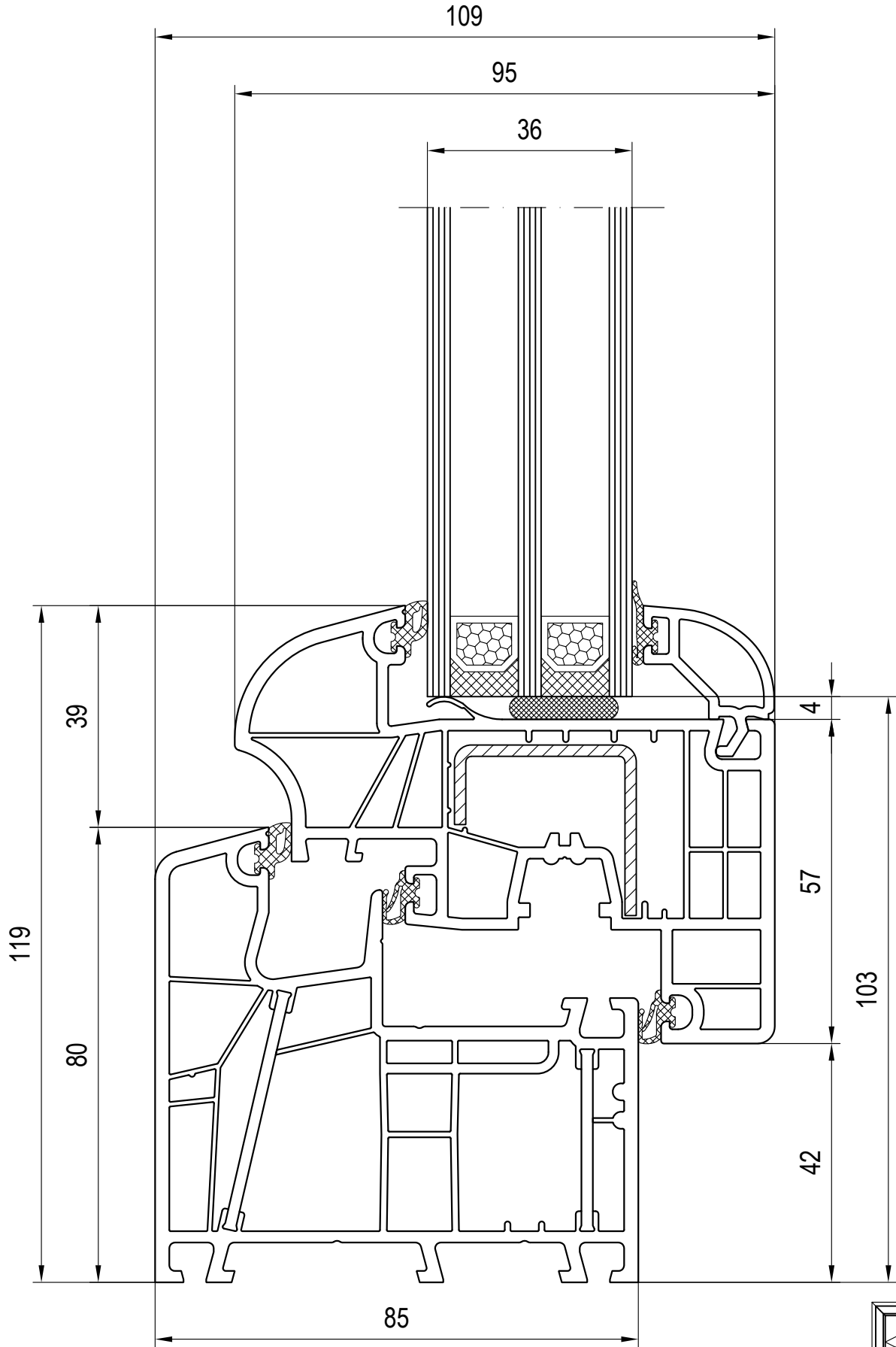

May be subject to change  
and errors excepted!

scale: 1:1  
03\_D\_01\_8\*

Combinations: Frame - Sash  
Glazing Bead 120650/120680

Frame 080x05  
Sash 180x85

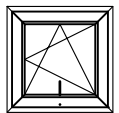
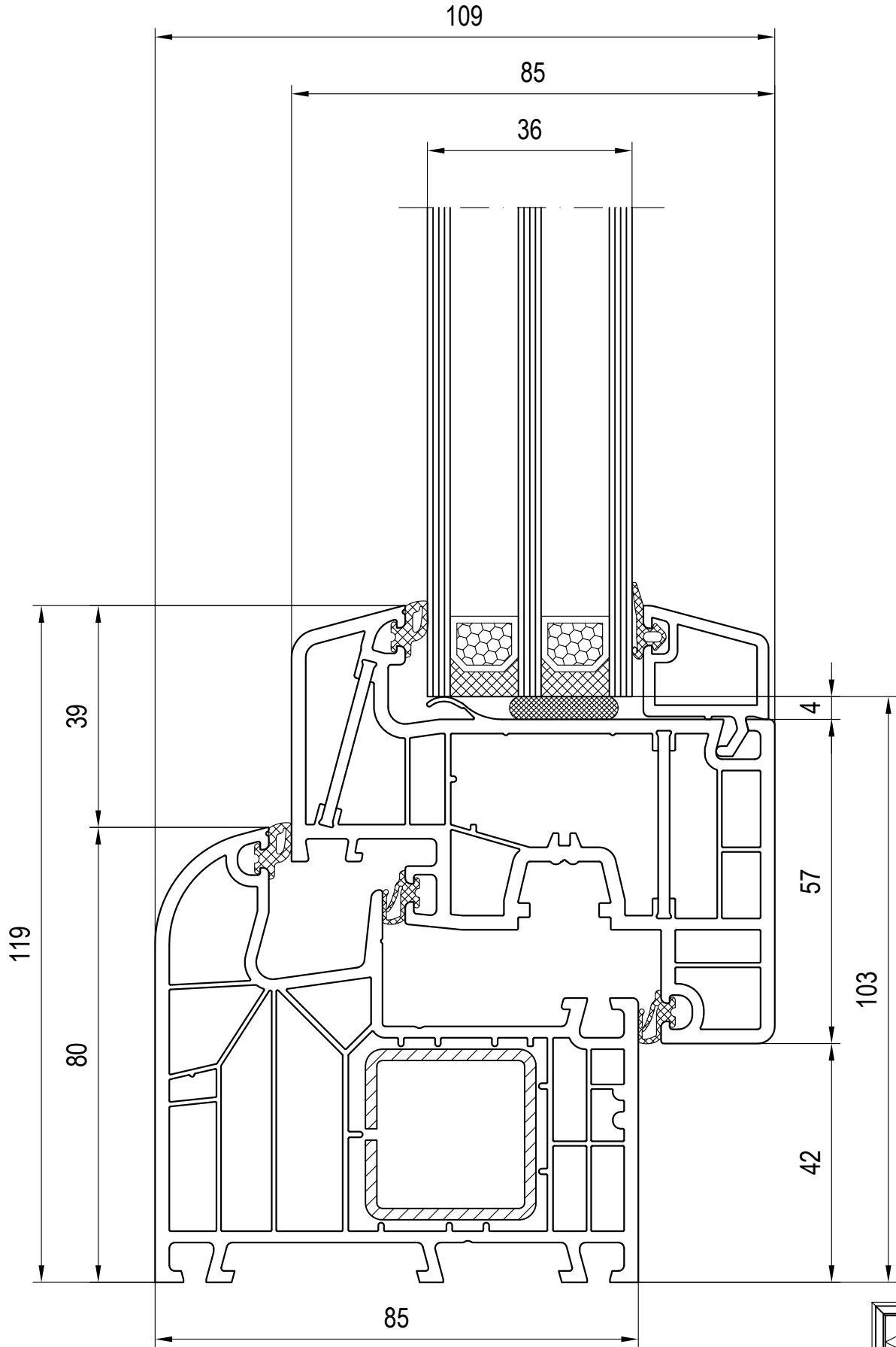

May be subject to change  
and errors excepted!

scale: 1:1  
03\_D\_01\_8\*

Combinations: Frame - Sash  
Glazing Bead 120636/120666

Frame 180x03  
Sash 080x86

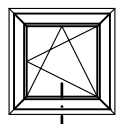
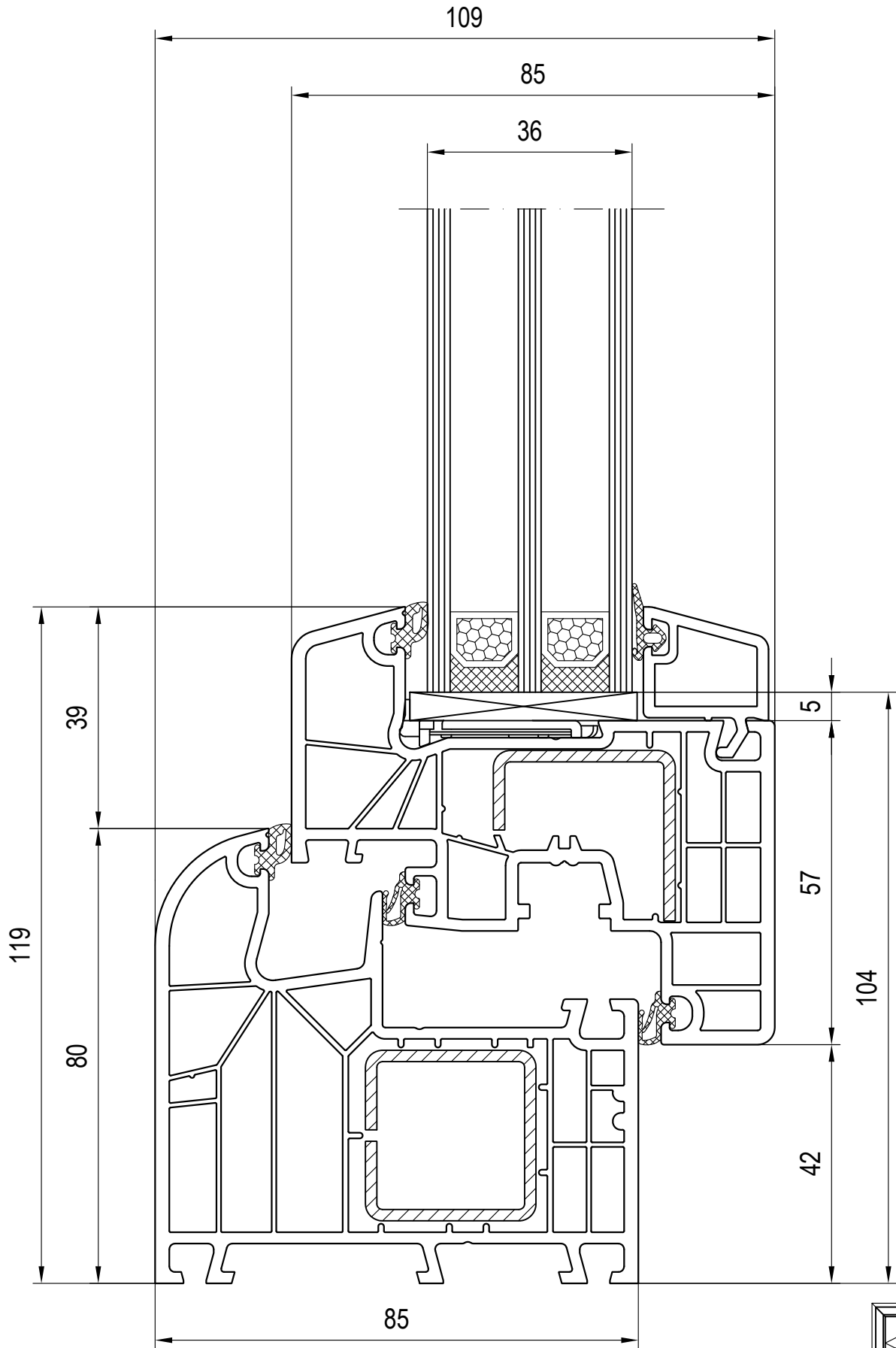

May be subject to change  
 and errors excepted!

scale: 1:1  
 03\_D\_01\_8\*

Combinations: Frame - Sash  
 Glazing Bead 120636/120666

Frame 180x03  
 Sash 180x20



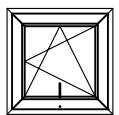
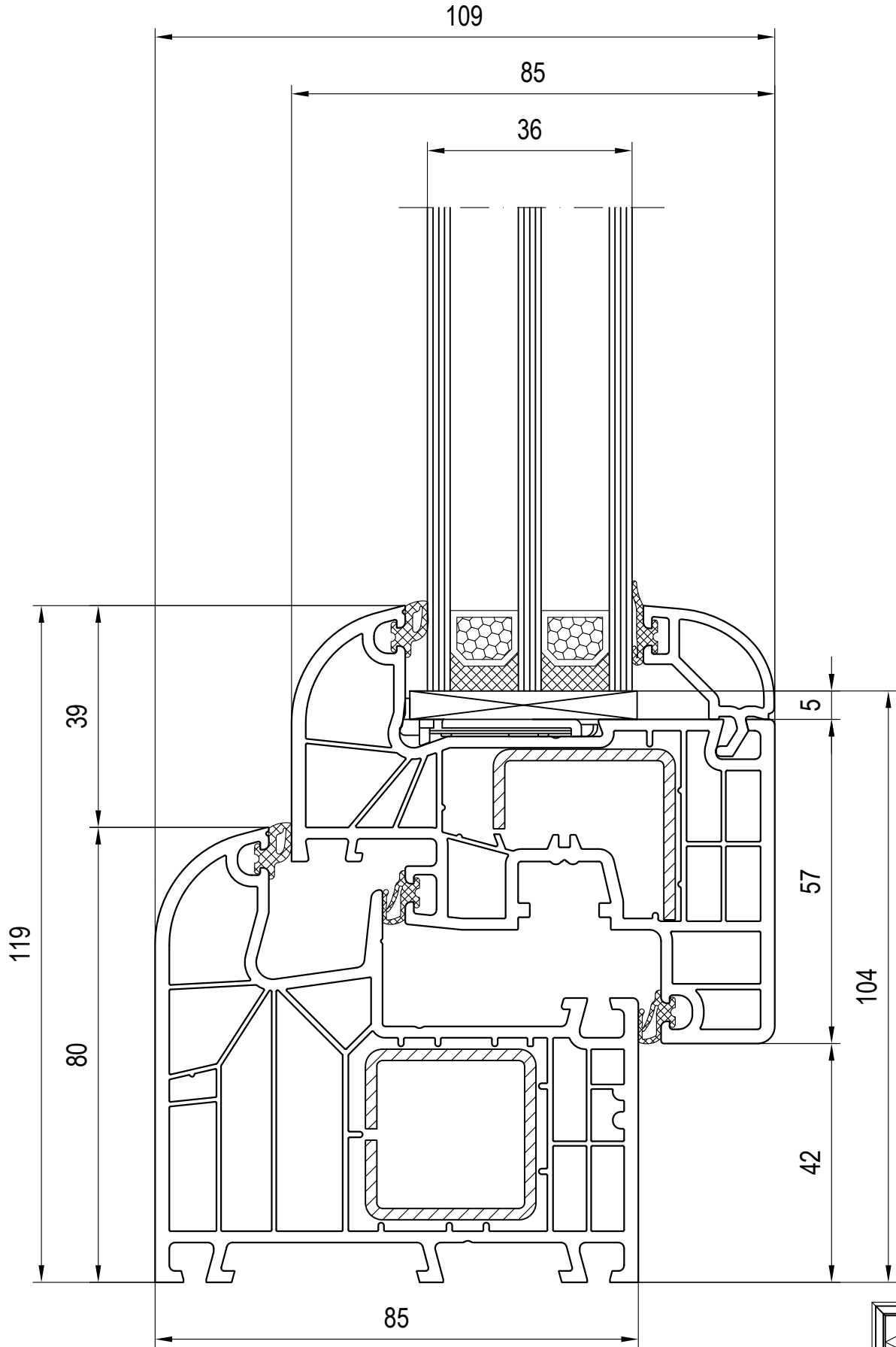

May be subject to change  
and errors excepted!

scale: 1:1  
03\_D\_01\_8\*

Combinations: Frame - Sash  
Glazing Bead 120650/120680

Frame 180x03  
Sash 180x22

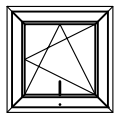
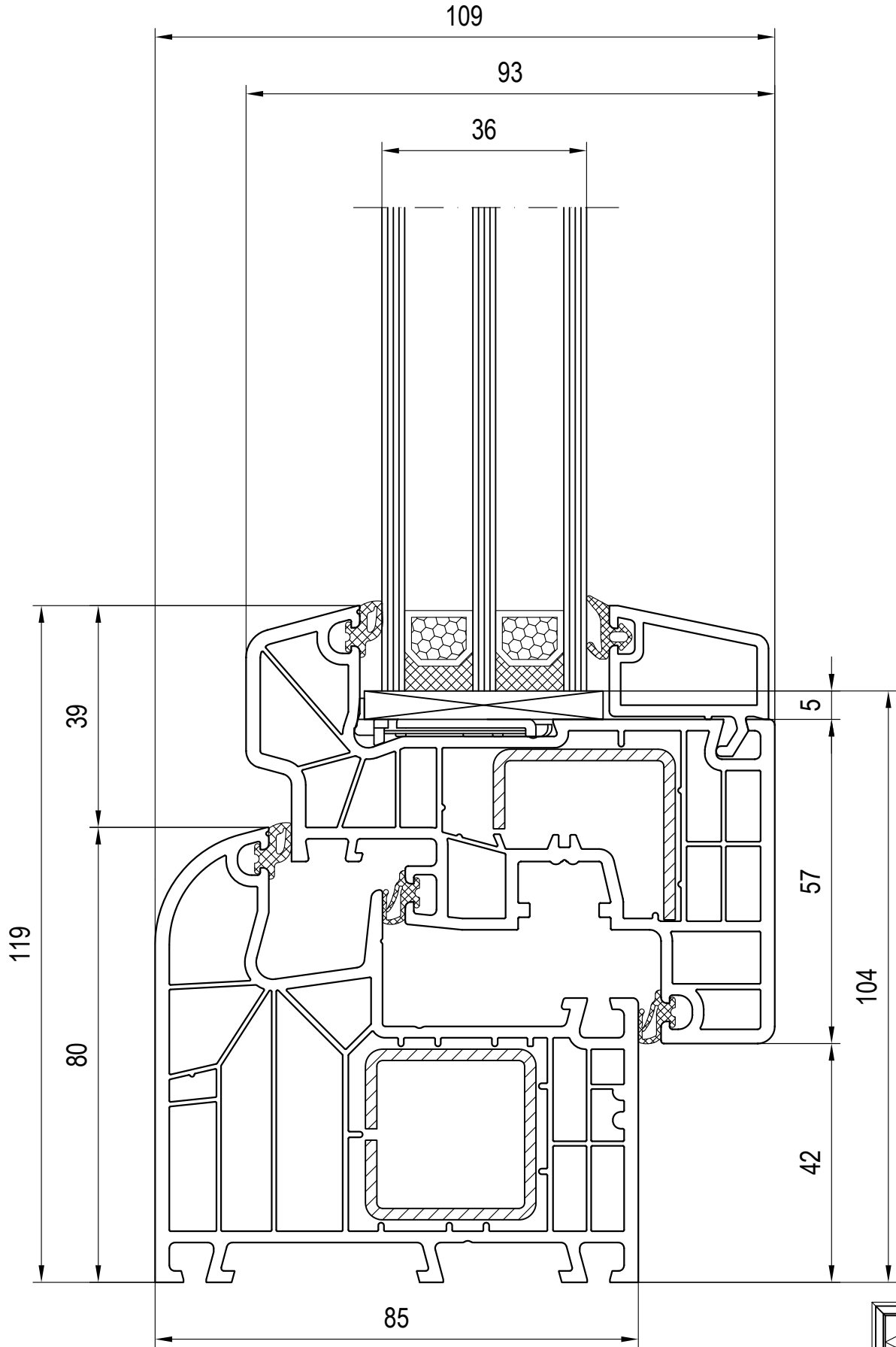

May be subject to change  
and errors excepted!

scale: 1:1  
03\_D\_01\_8\*

Combinations: Frame - Sash  
Glazing Bead 120838/120868

Frame 180x03  
Sash 180x26

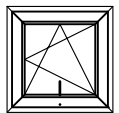
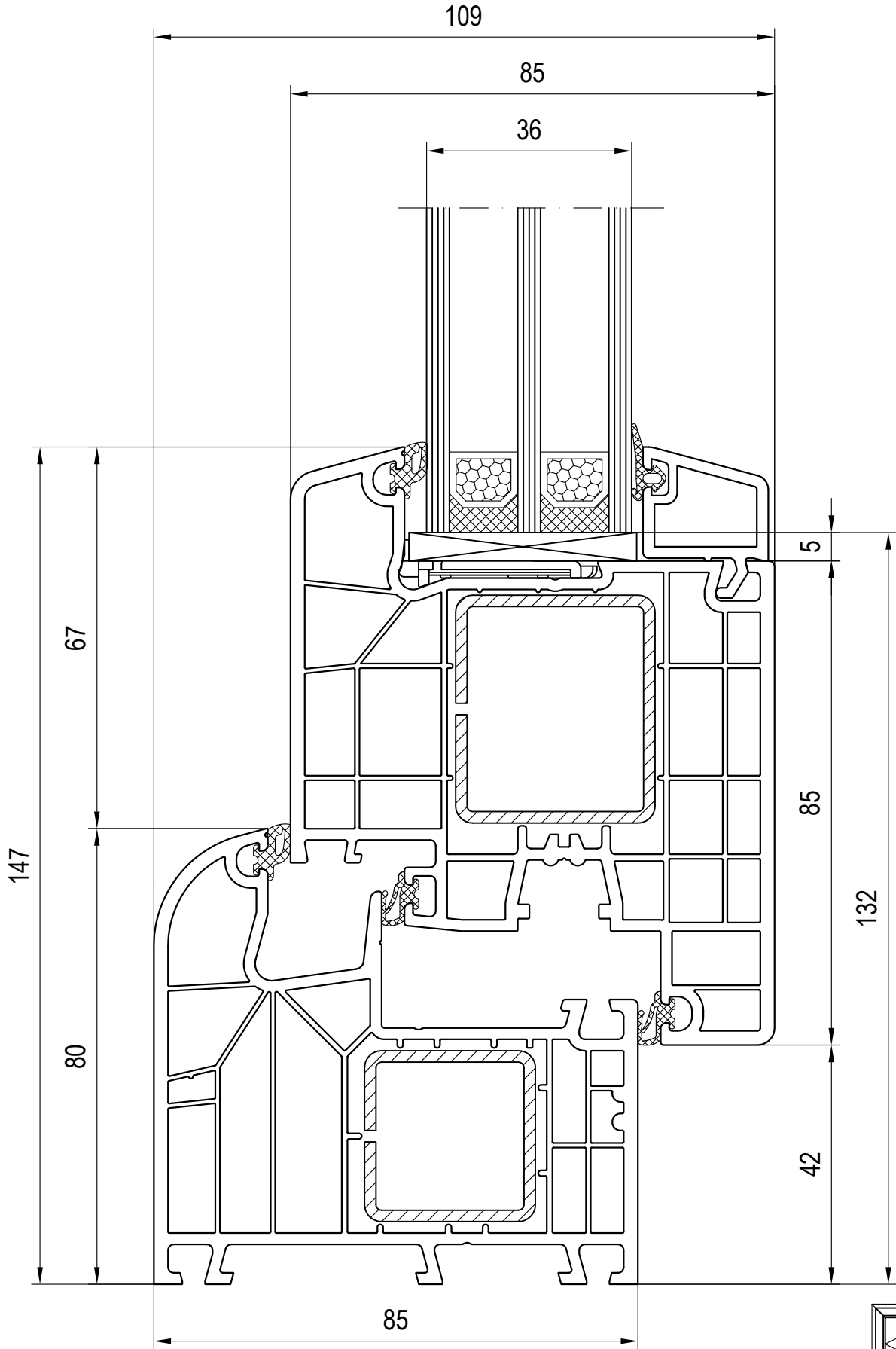

May be subject to change  
and errors excepted!

scale: 1:1  
03\_D\_01\_8\*

Combinations: Frame - Sash  
Glazing Bead 120636/120666

Frame 180x03  
Sash 180x30

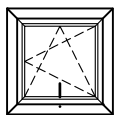
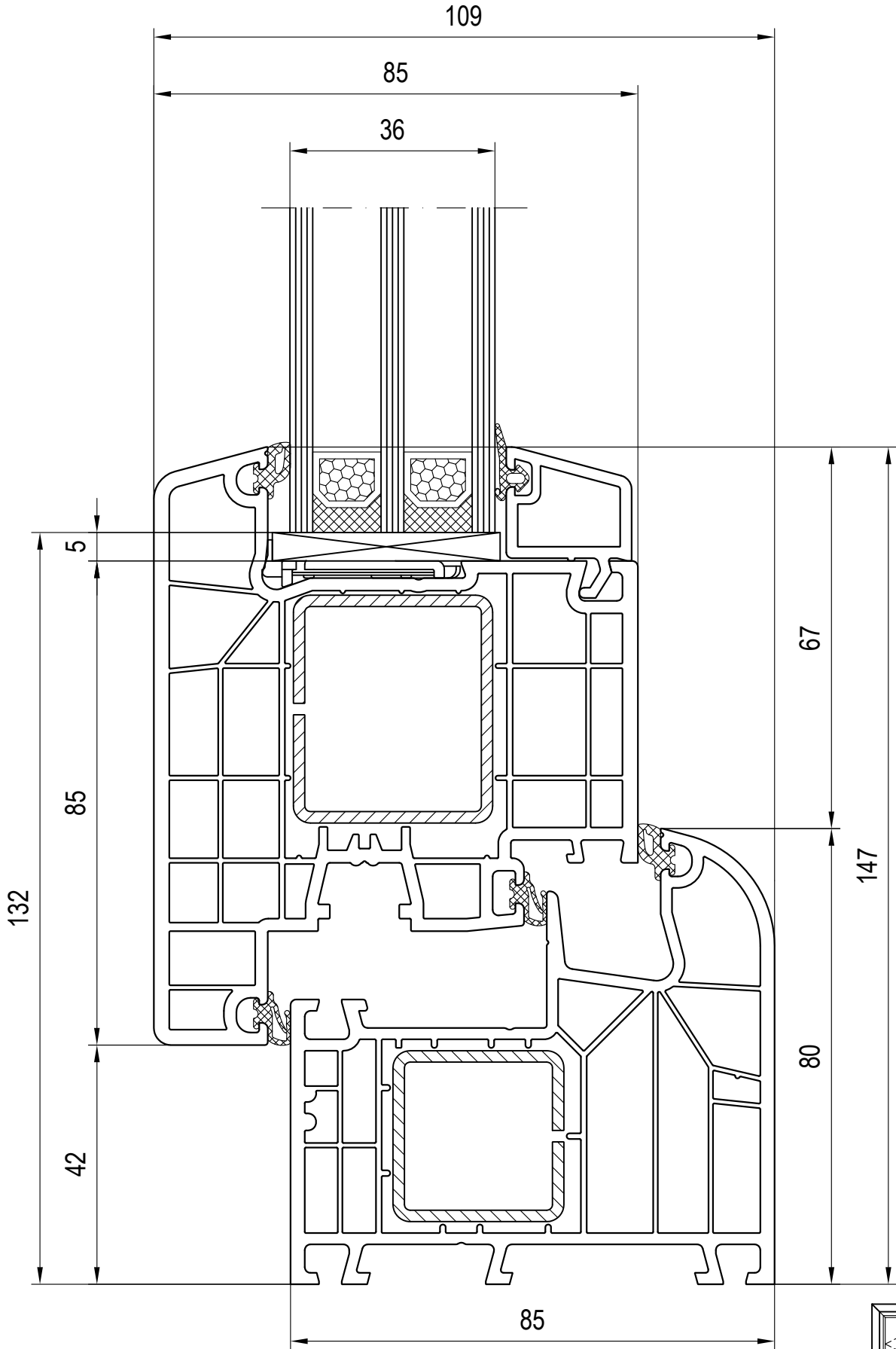

May be subject to change and errors excepted!

scale: 1:1  
 03\_D\_01\_8\*

Combinations: Frame - Sash  
 Glazing Bead 120636/120666

Frame 180x03  
 Sash 180x31

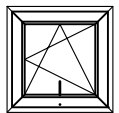
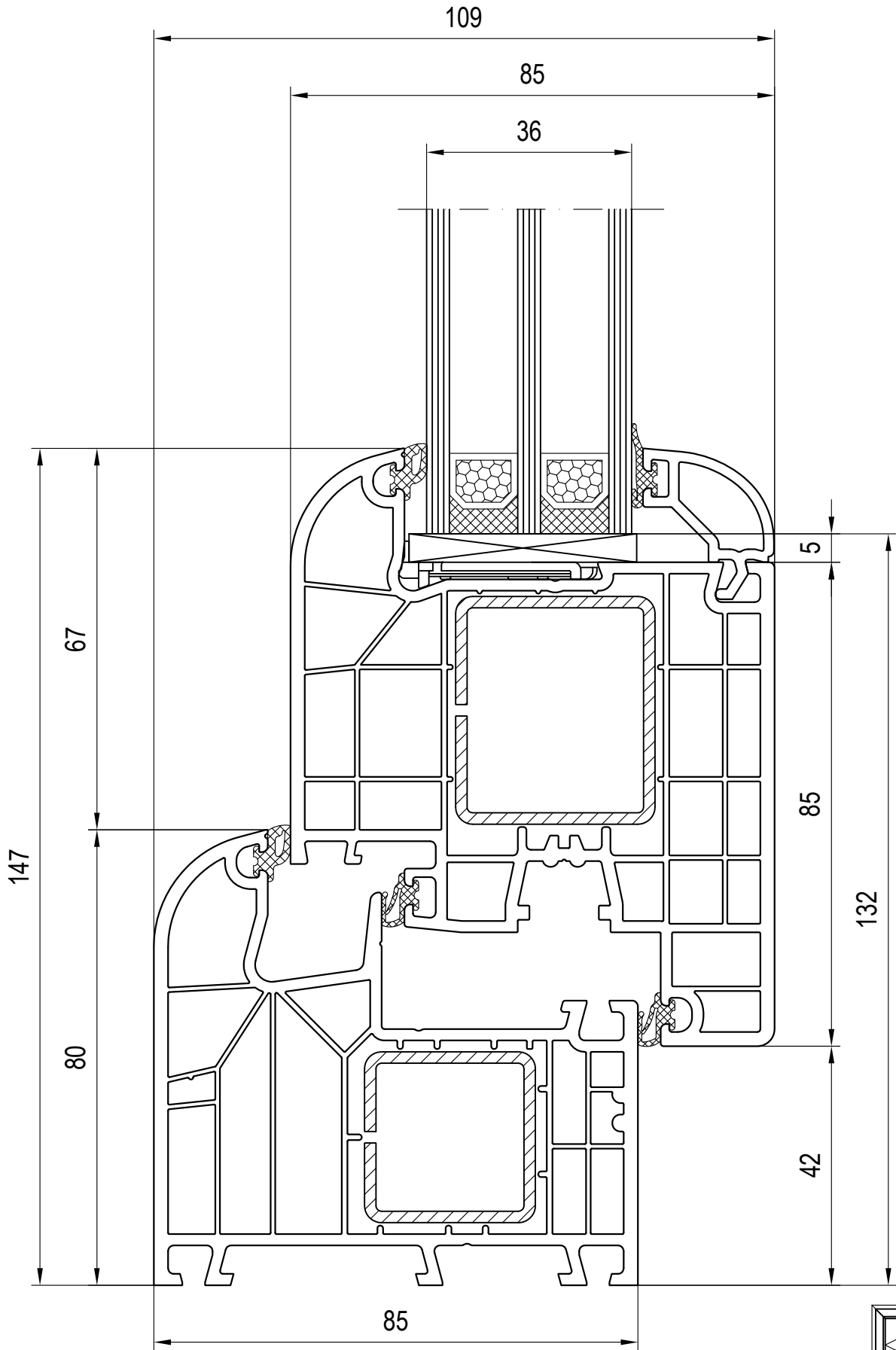

May be subject to change  
and errors excepted!

scale: 1:1  
03\_D\_01\_8\*

Combinations: Frame - Sash  
Glazing Bead 120650/120680

Frame 180x03  
Sash 180x32

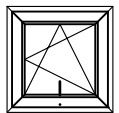
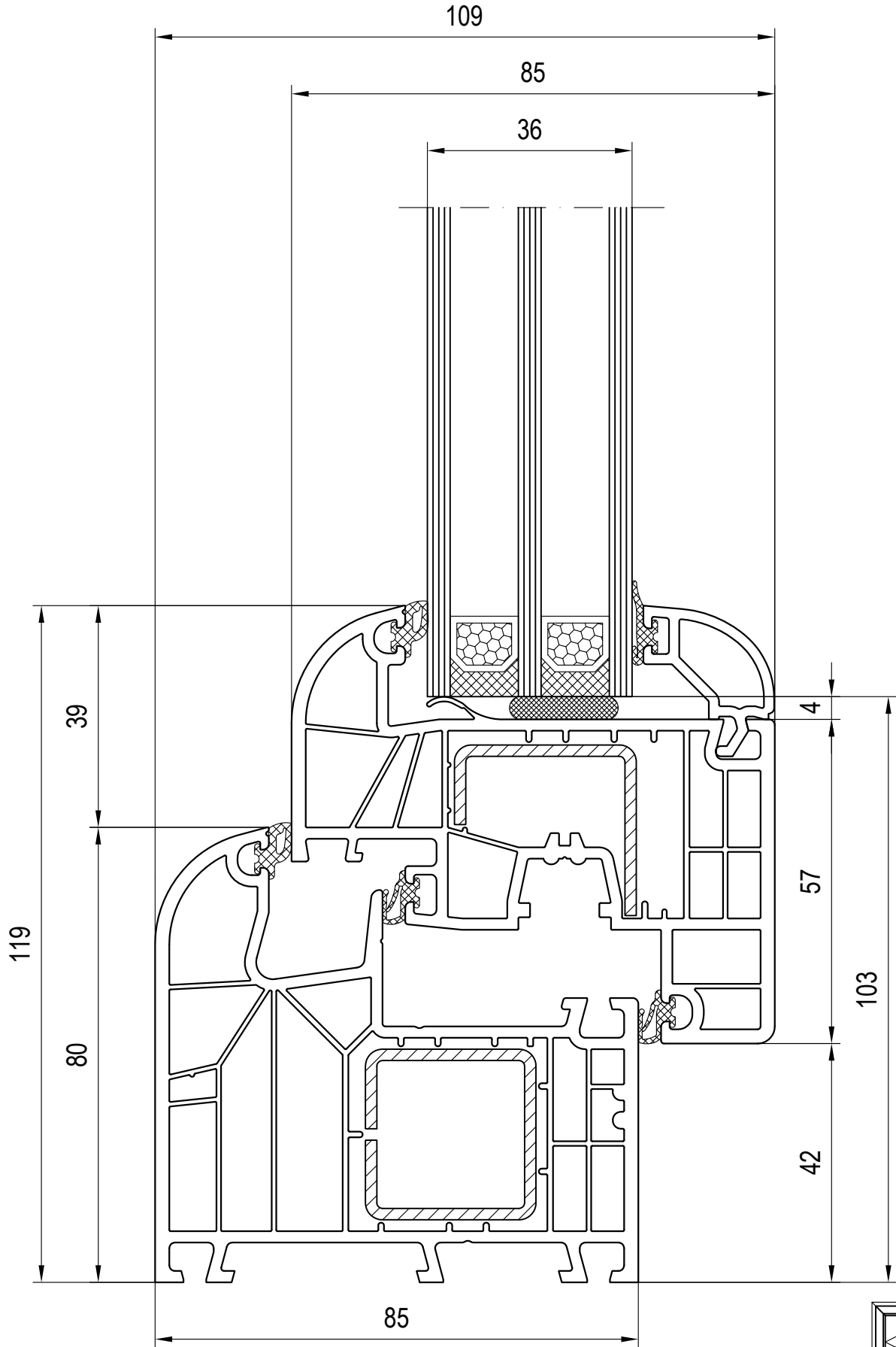

May be subject to change  
 and errors excepted!

scale: 1:1  
 03\_D\_01\_8\*

Combinations: Frame - Sash  
 Glazing Bead 120650/120680

Frame 180x03  
 Sash 180x83

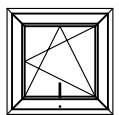
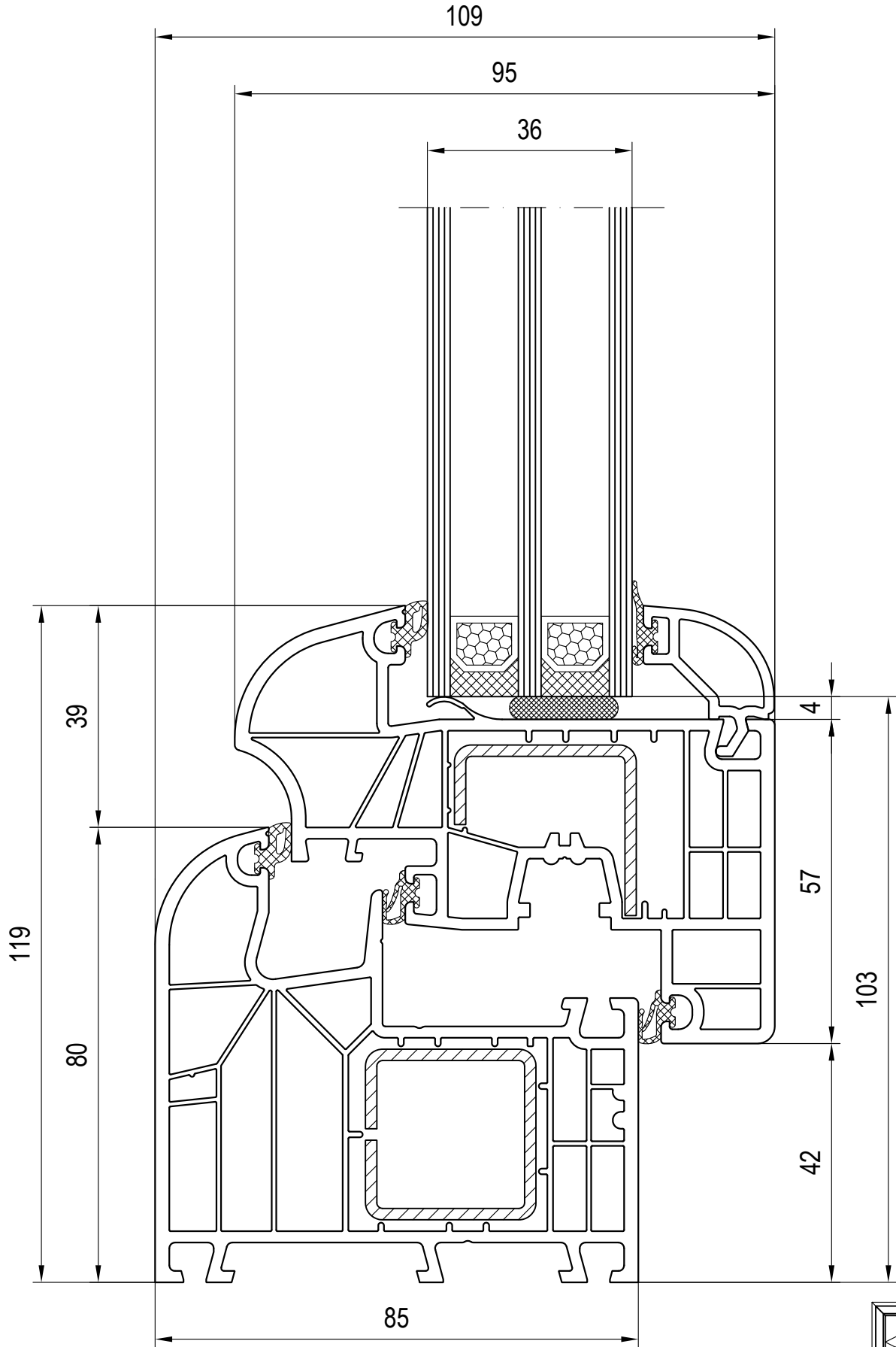

May be subject to change  
and errors excepted!

scale: 1:1  
03\_D\_01\_8\*

Combinations: Frame - Sash  
Glazing Bead 120650/120680

Frame 180x03  
Sash 180x85

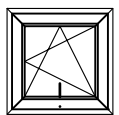
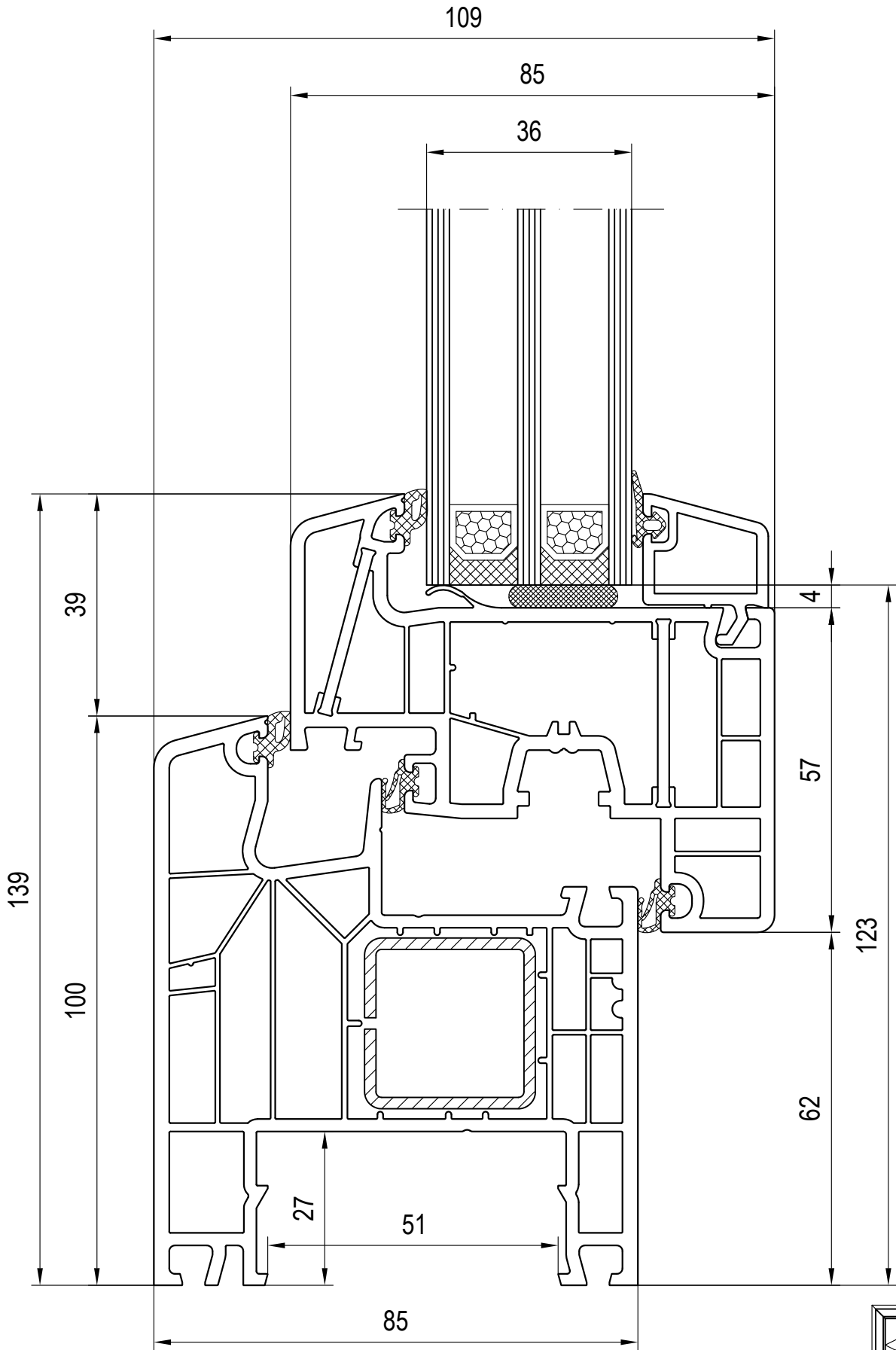

May be subject to change  
 and errors excepted!

scale: 1:1  
 03\_D\_01\_8\*

Combinations: Frame - Sash  
 Glazing Bead 120636/120666

Frame 180x04  
 Sash 080x86



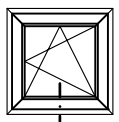
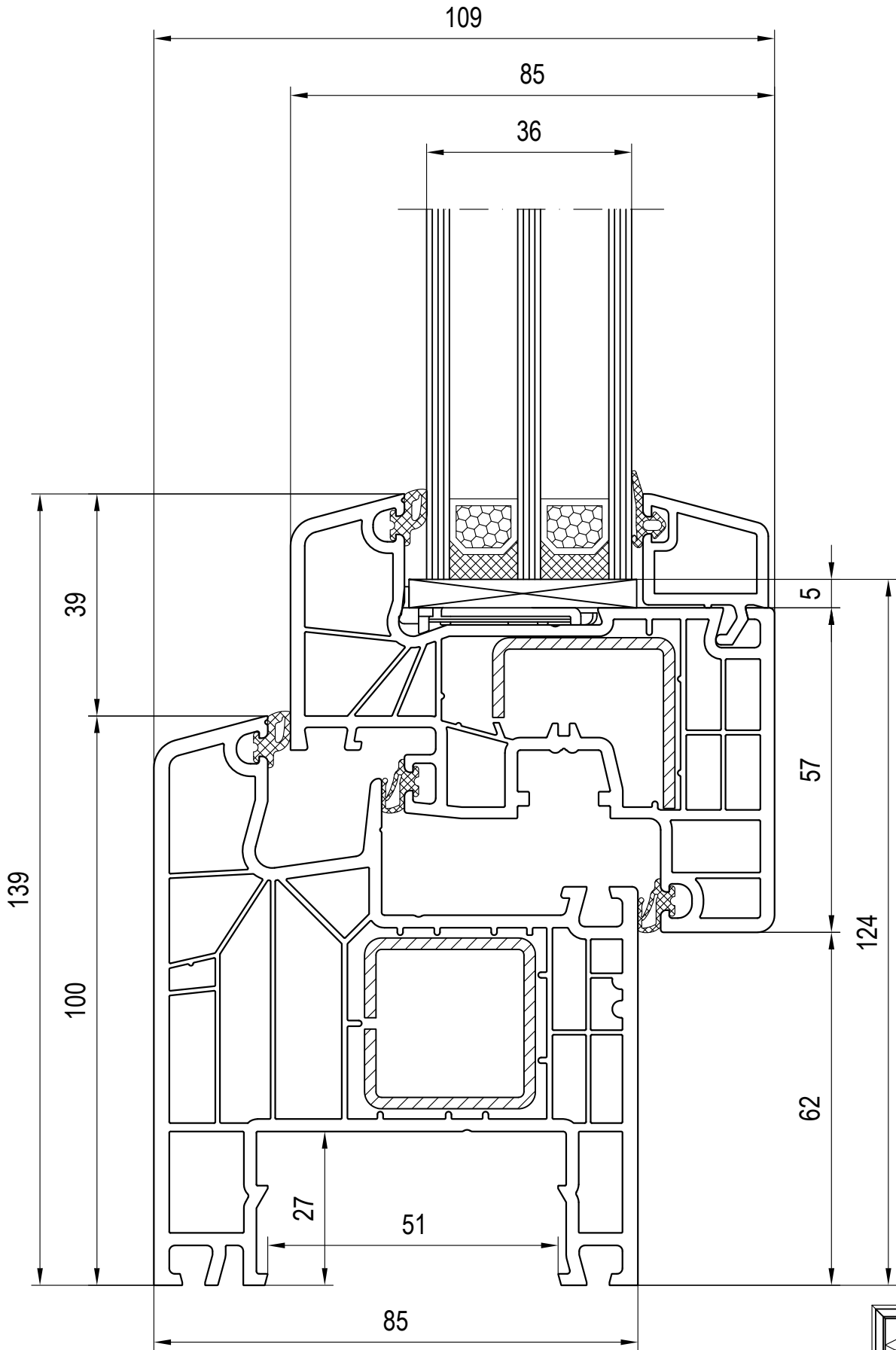

May be subject to change and errors excepted!

scale: 1:1  
 03\_D\_01\_8\*

Combinations: Frame - Sash  
 Glazing Bead 120636/120666

Frame 180x04  
 Sash 180x20

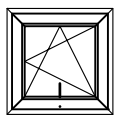
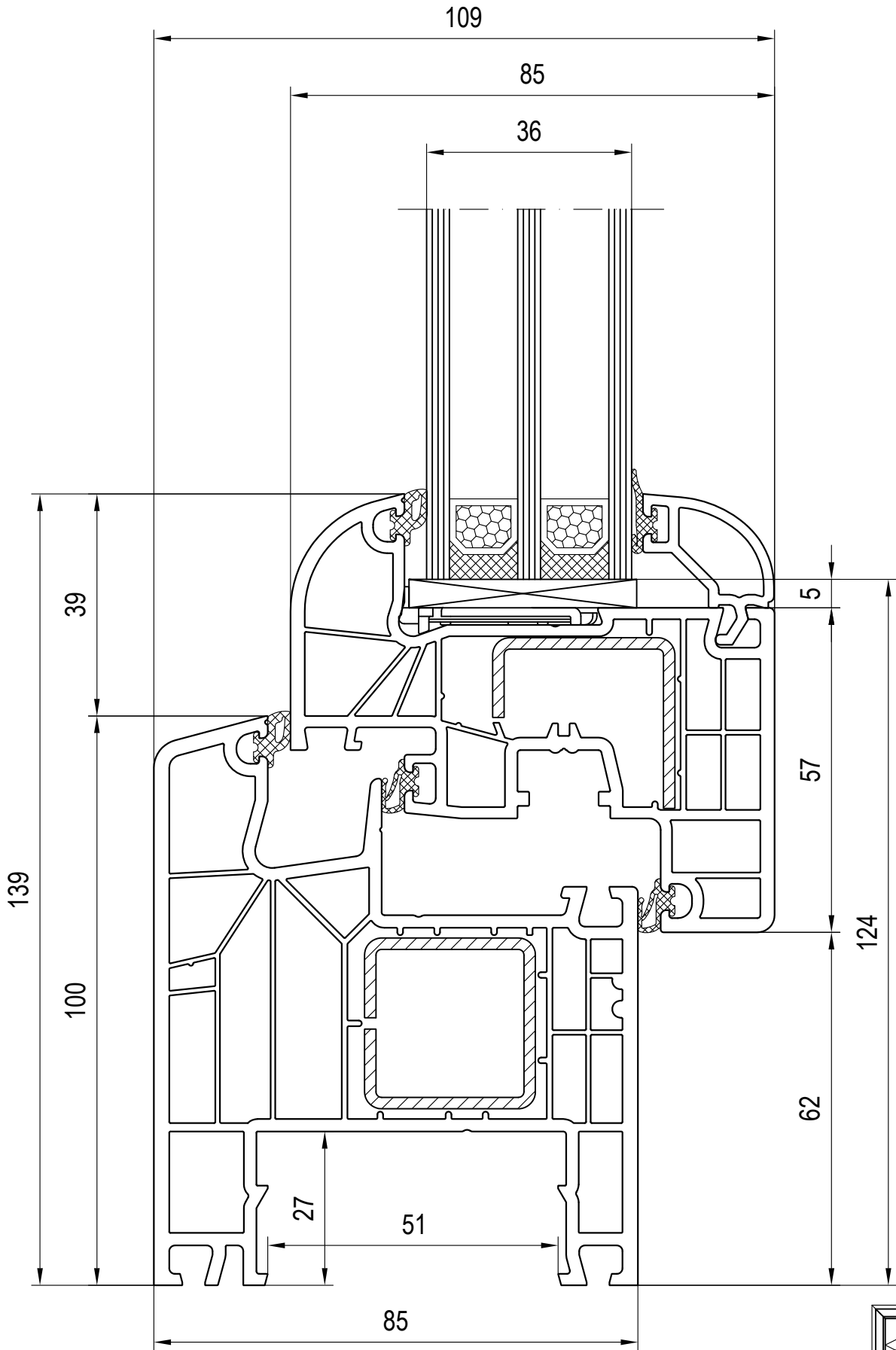

May be subject to change  
 and errors excepted!

scale: 1:1  
 03\_D\_01\_8\*

Combinations: Frame - Sash  
 Glazing Bead 120650/120680

Frame 180x04  
 Sash 180x22

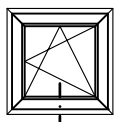
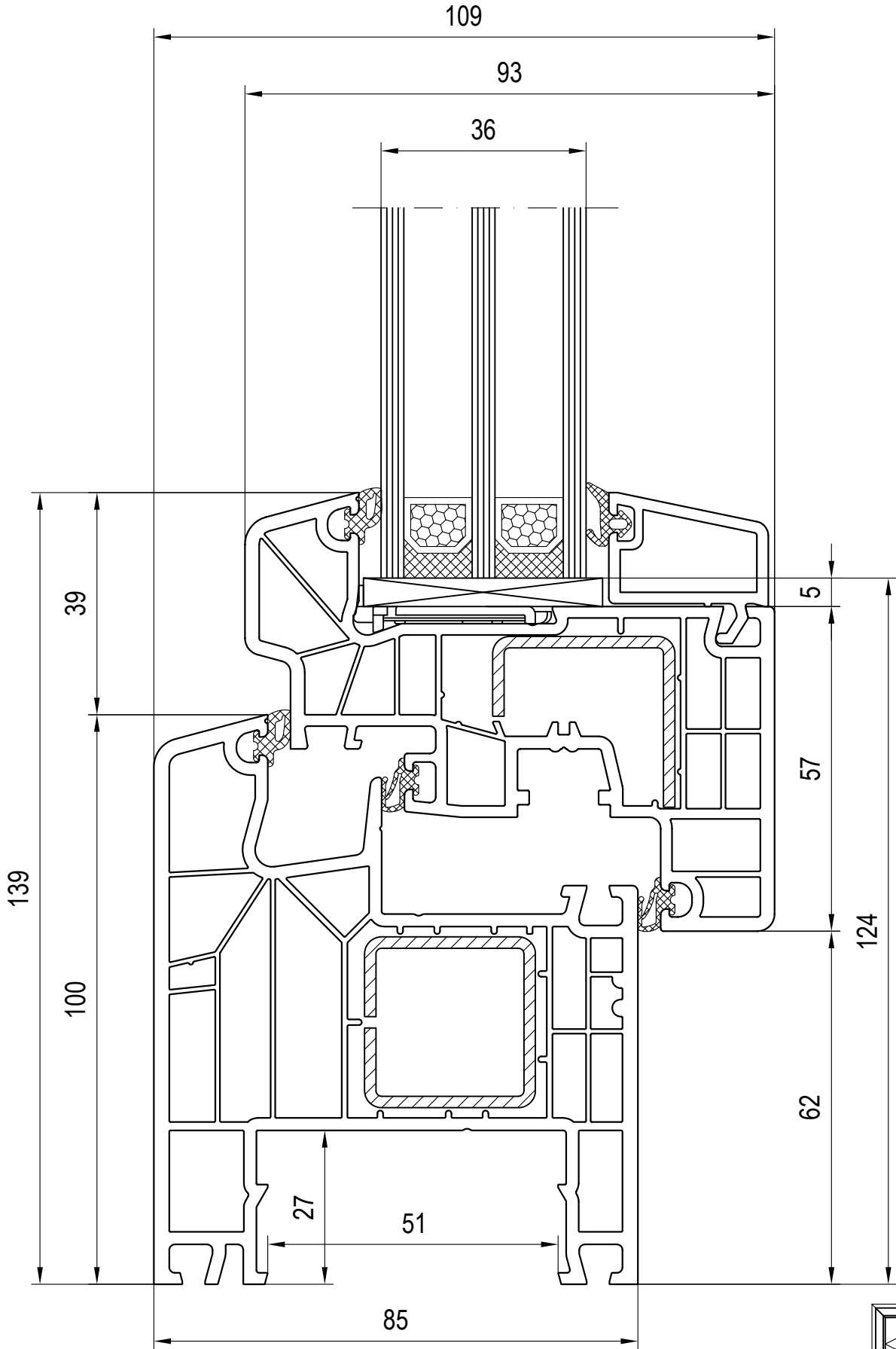

May be subject to change  
and errors excepted!

scale: 1:1  
03\_D\_01\_8\*

Combinations: Frame - Sash  
Glazing Bead 120838/120868

Frame 180x04  
Sash 180x26

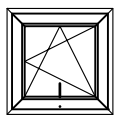
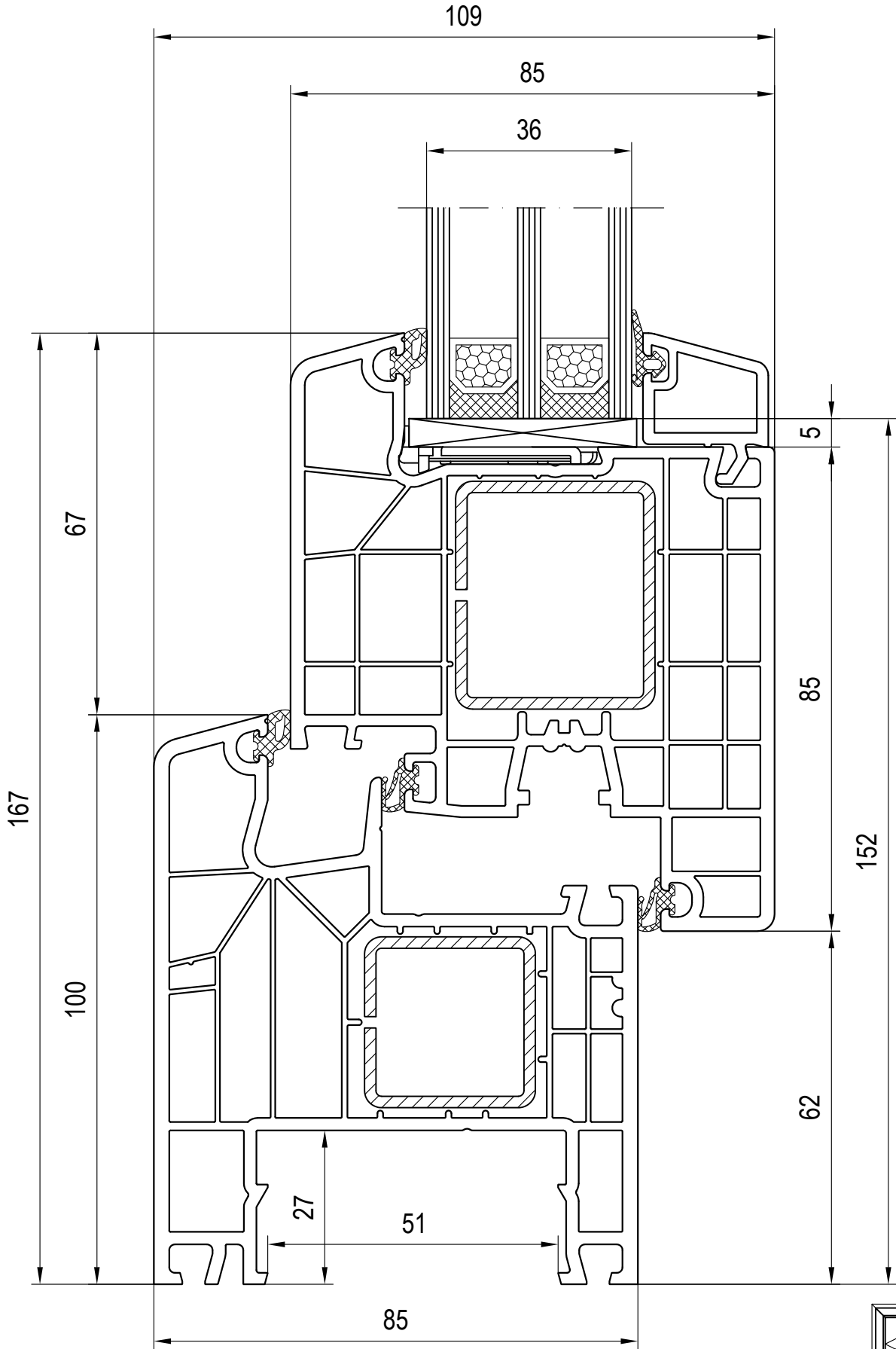

May be subject to change  
 and errors excepted!

scale: 1:1  
 03\_D\_01\_8\*

Combinations: Frame - Sash  
 Glazing Bead 120636/120666

Frame 180x04  
 Sash 180x30

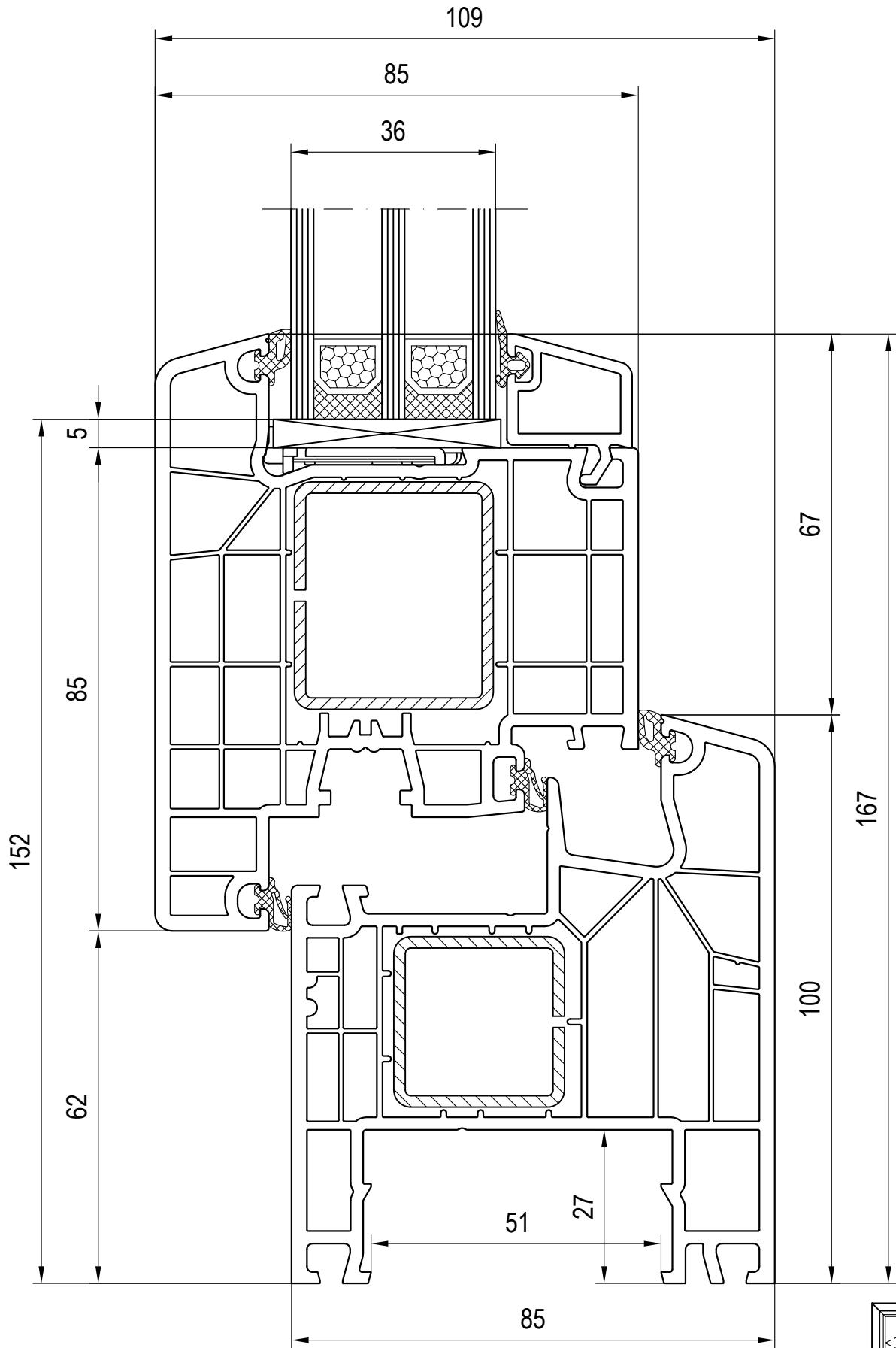

May be subject to change and errors excepted!

scale: 1:1  
03\_D\_01\_8\*

Combinations: Frame - Sash  
Glazing Bead 120636/120666

Frame 180x04  
Sash 180x31

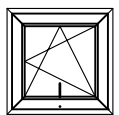
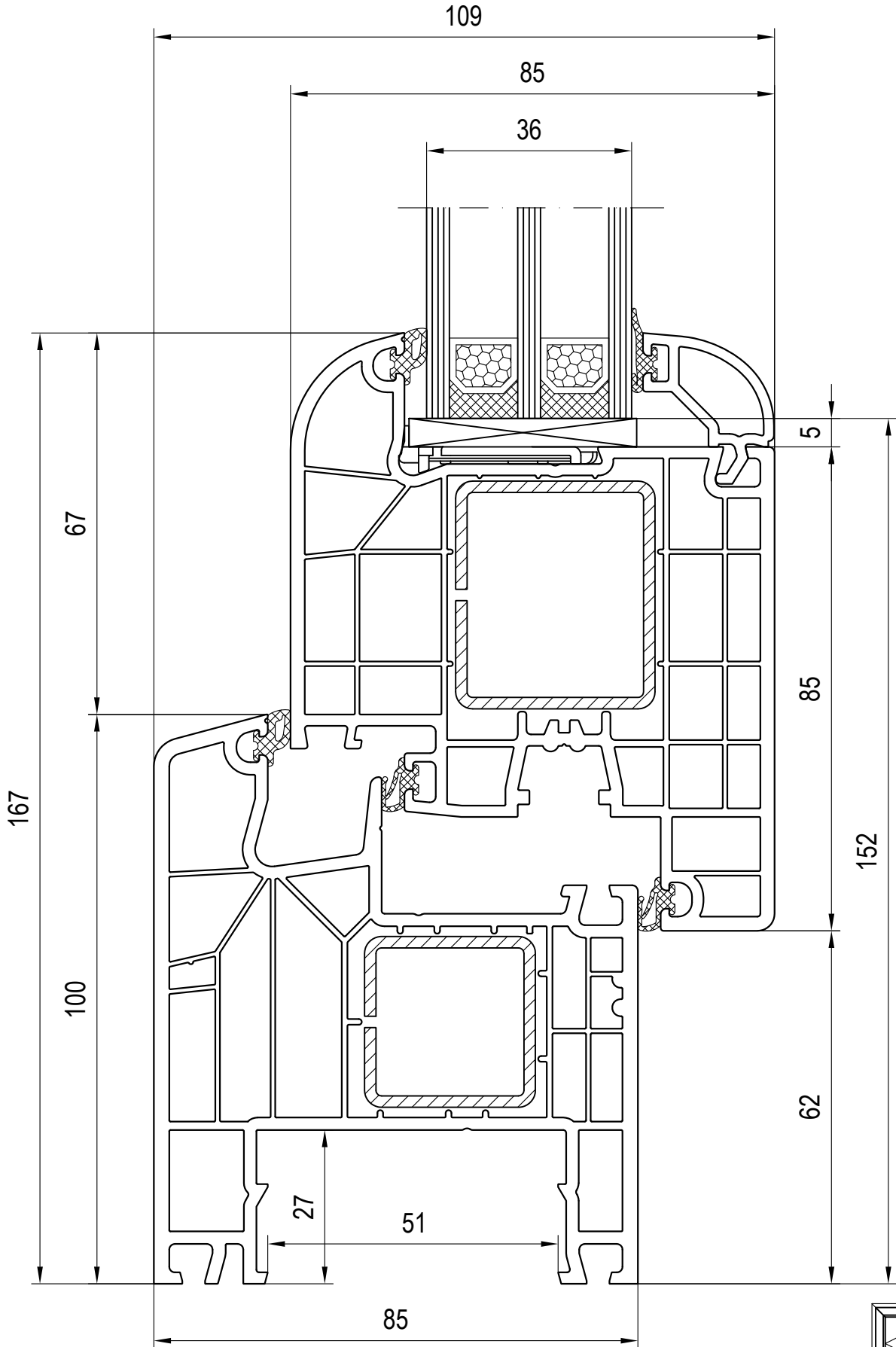

May be subject to change  
and errors excepted!

scale: 1:1  
03\_D\_01\_8\*

Combinations: Frame - Sash  
Glazing Bead 120650/120680

Frame 180x04  
Sash 180x32

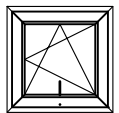
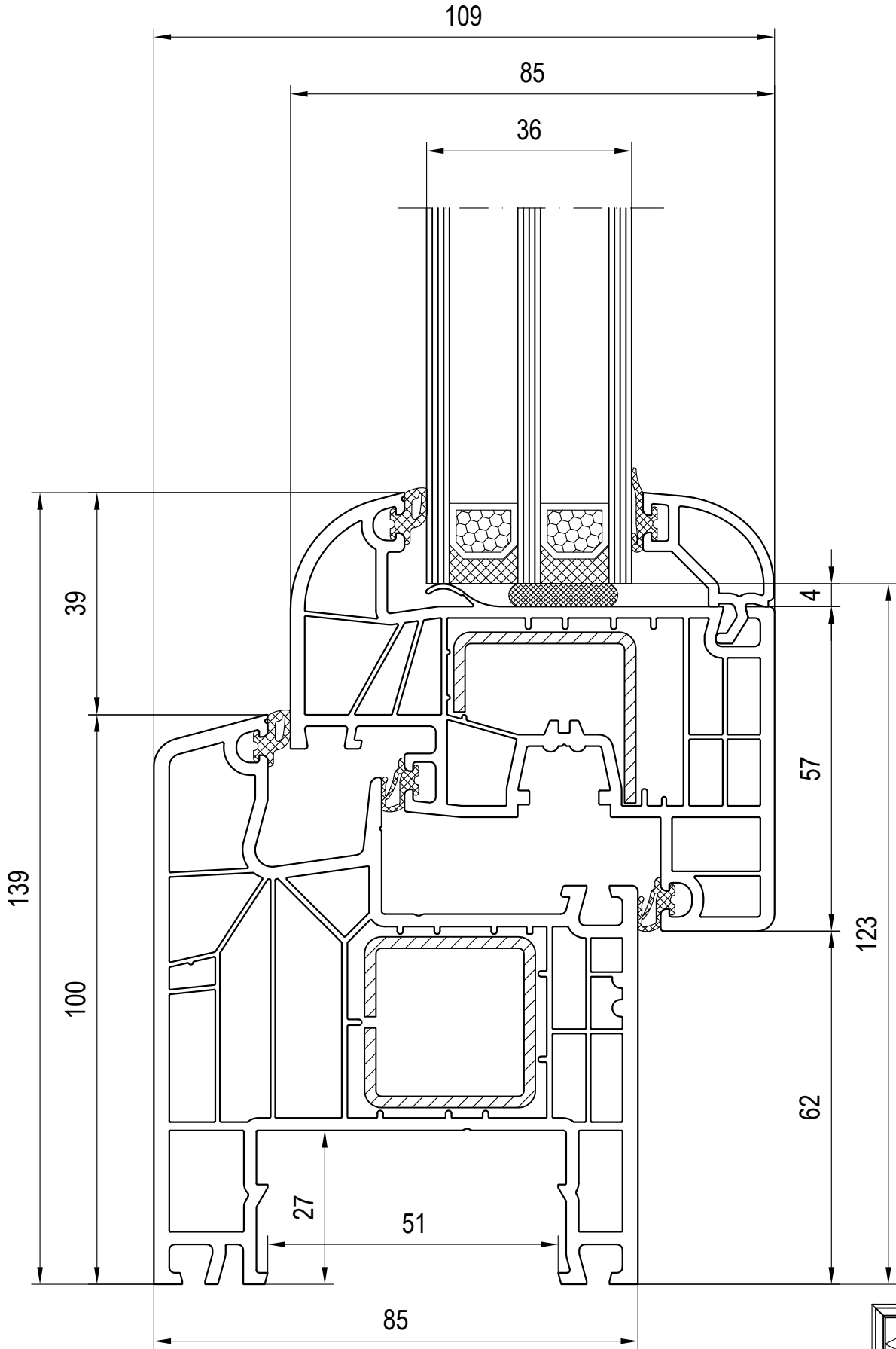

May be subject to change and errors excepted!

scale: 1:1  
03\_D\_01\_8\*

Combinations: Frame - Sash  
Glazing Bead 120650/120680

Frame 180x04  
Sash 180x83

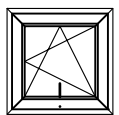
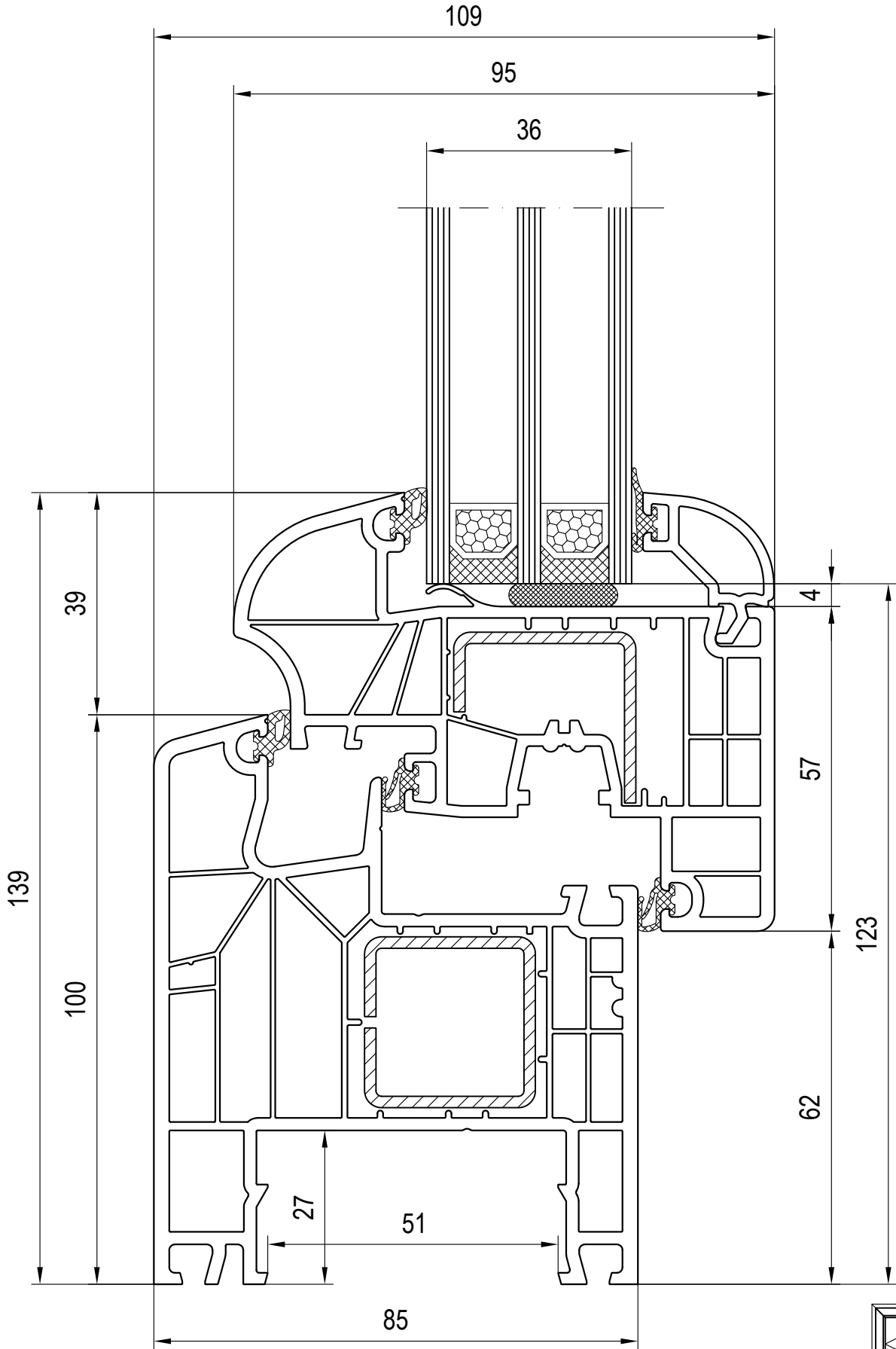

May be subject to change  
 and errors excepted!

scale: 1:1  
 03\_D\_01\_8\*

Combinations: Frame - Sash  
 Glazing Bead 120650/120680

Frame 180x04  
 Sash 180x85



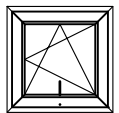
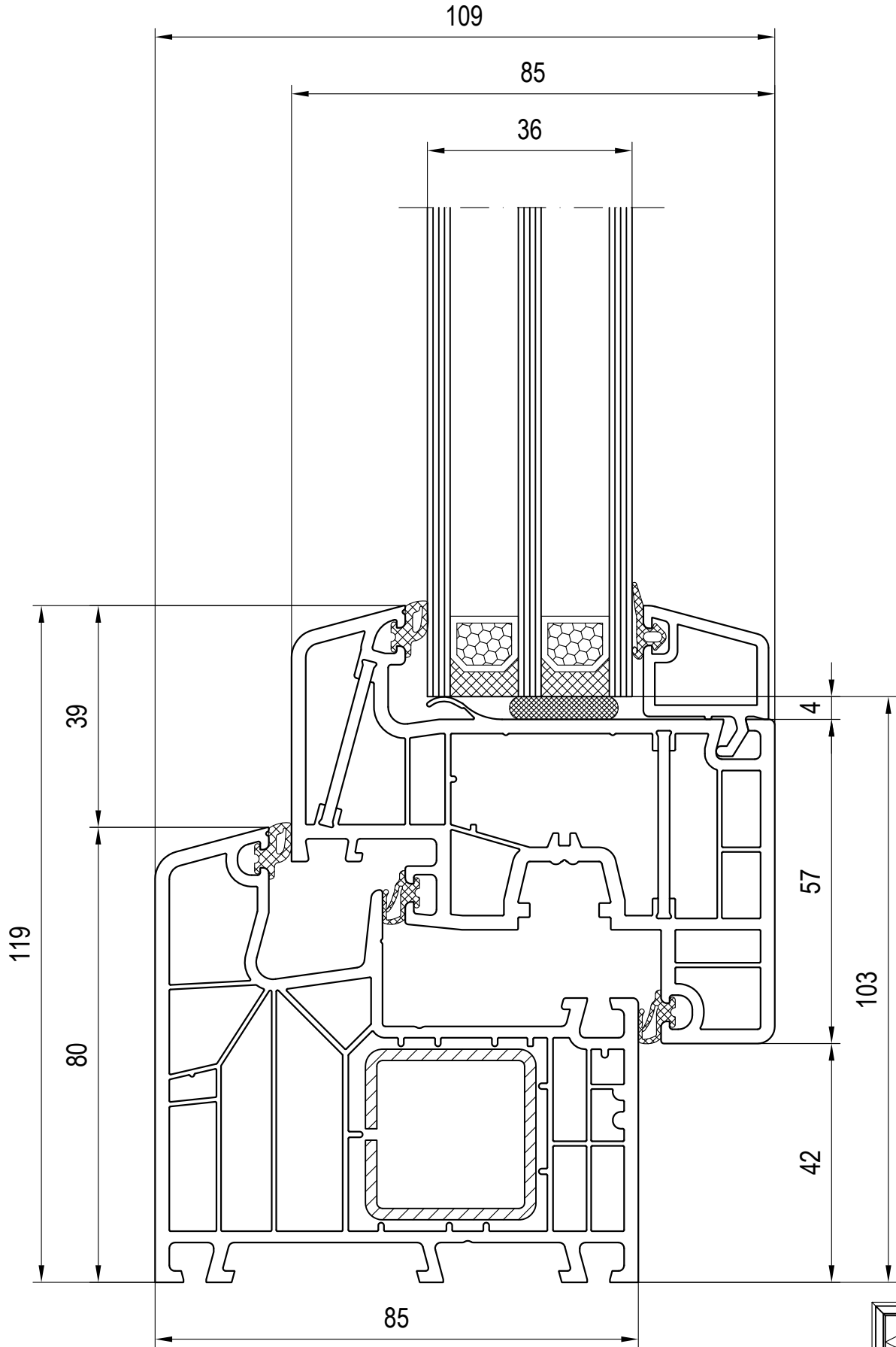

May be subject to change  
 and errors excepted!

scale: 1:1  
 03\_D\_01\_8\*

Combinations: Frame - Sash  
 Glazing Bead 120636/120666

Frame 180x05  
 Sash 080x86

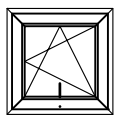
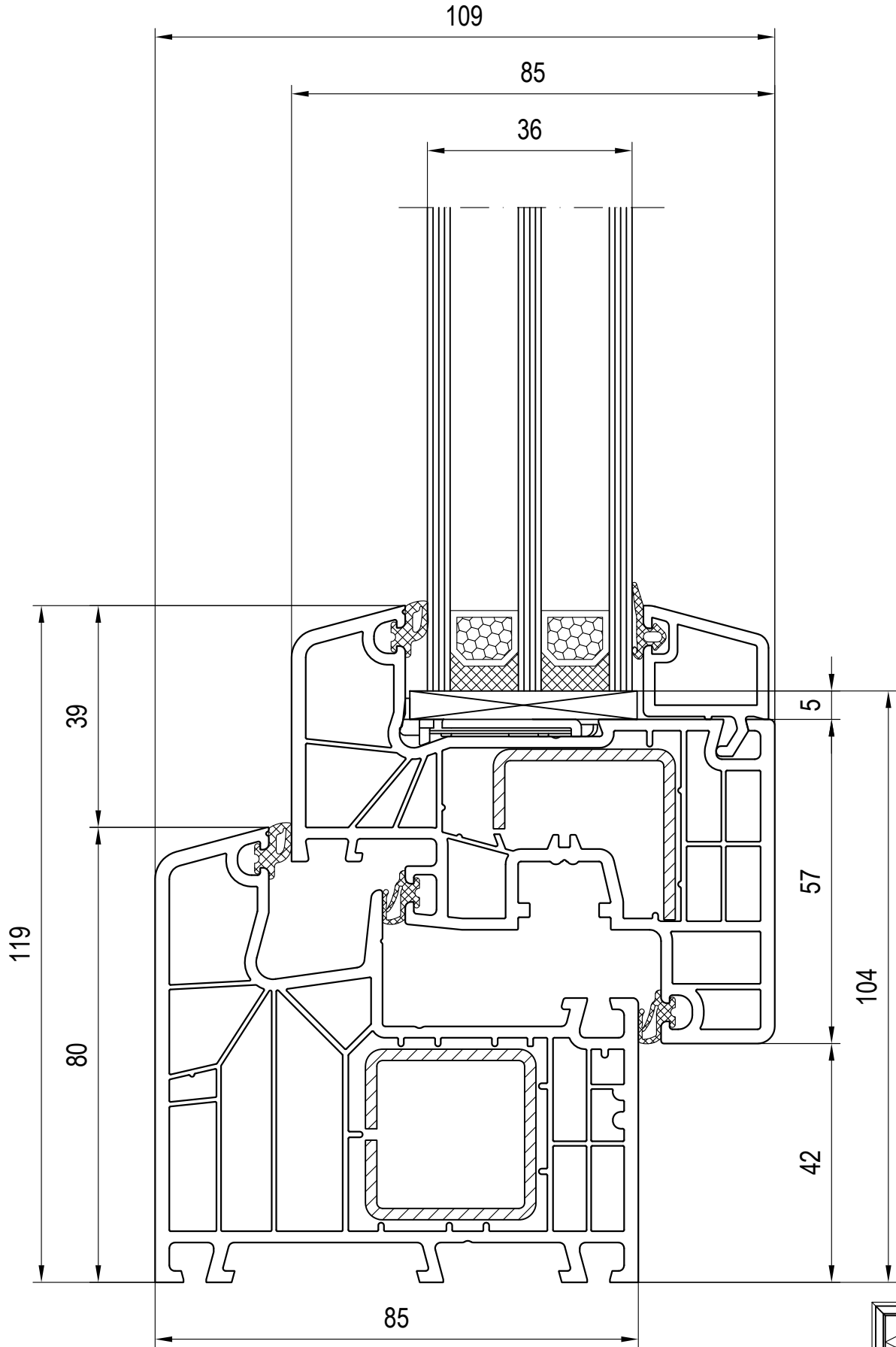

May be subject to change  
and errors excepted!

scale: 1:1  
03\_D\_01\_8\*

Combinations: Frame - Sash  
Glazing Bead 120636/120666

Frame 180x05  
Sash 180x20

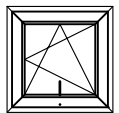
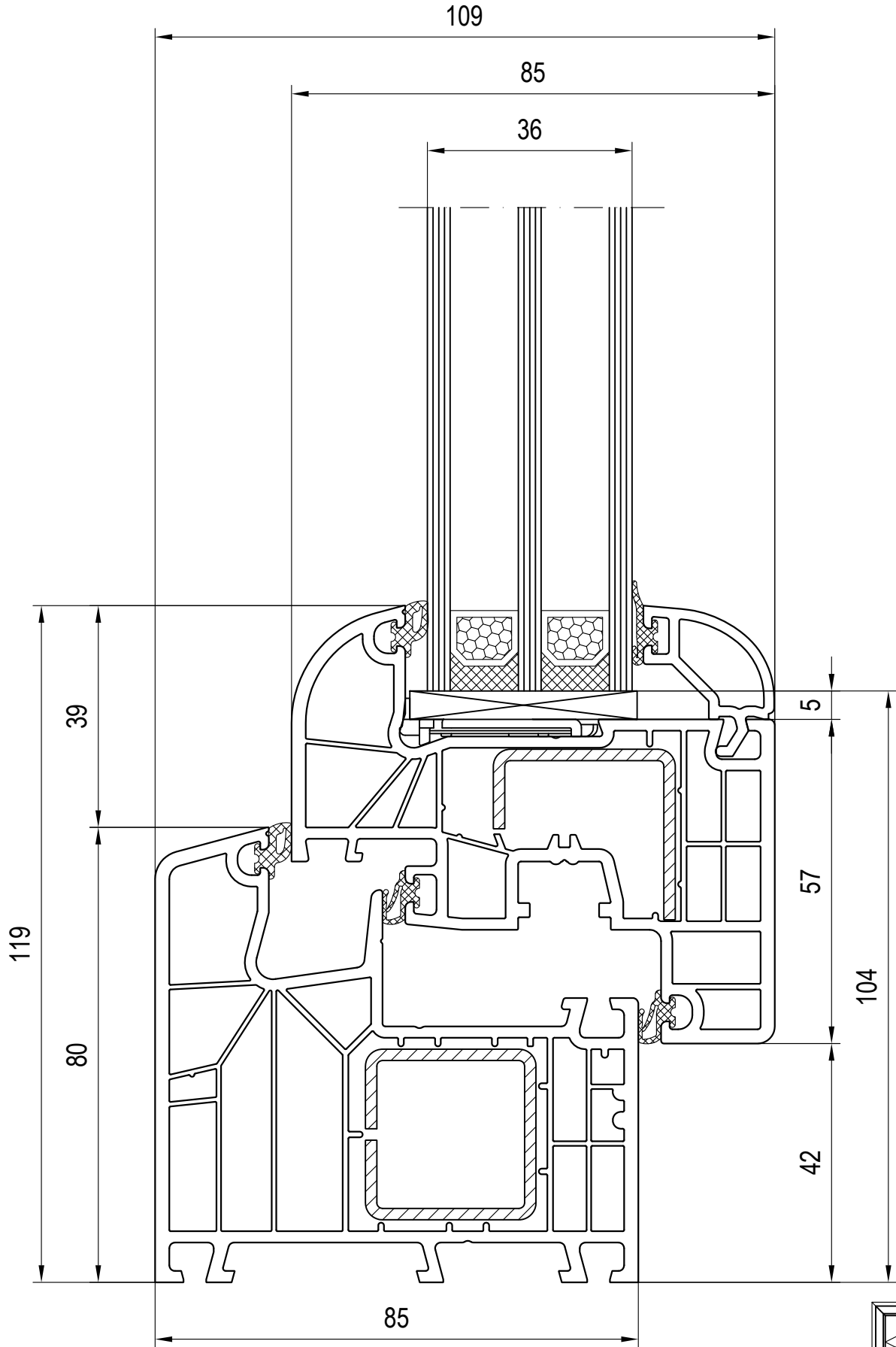

May be subject to change  
 and errors excepted!

scale: 1:1  
 03\_D\_01\_8\*

Combinations: Frame - Sash  
 Glazing Bead 120650/120680

Frame 180x05  
 Sash 180x22

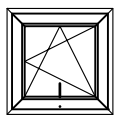
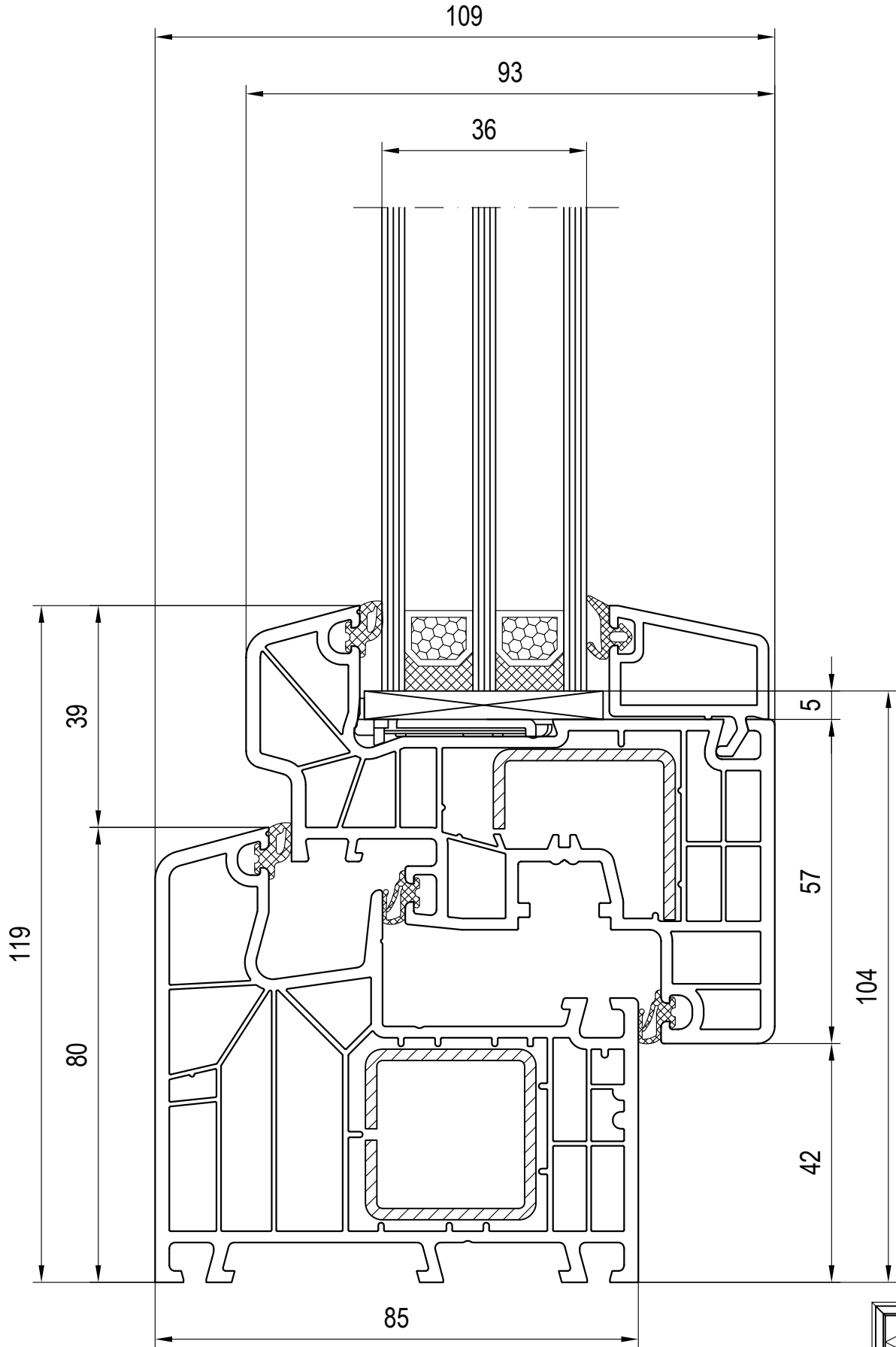

May be subject to change  
and errors excepted!

scale: 1:1  
03\_D\_01\_8\*

Combinations: Frame - Sash  
Glazing Bead 120838/120868

Frame 180x05  
Sash 180x26

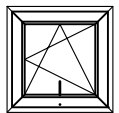
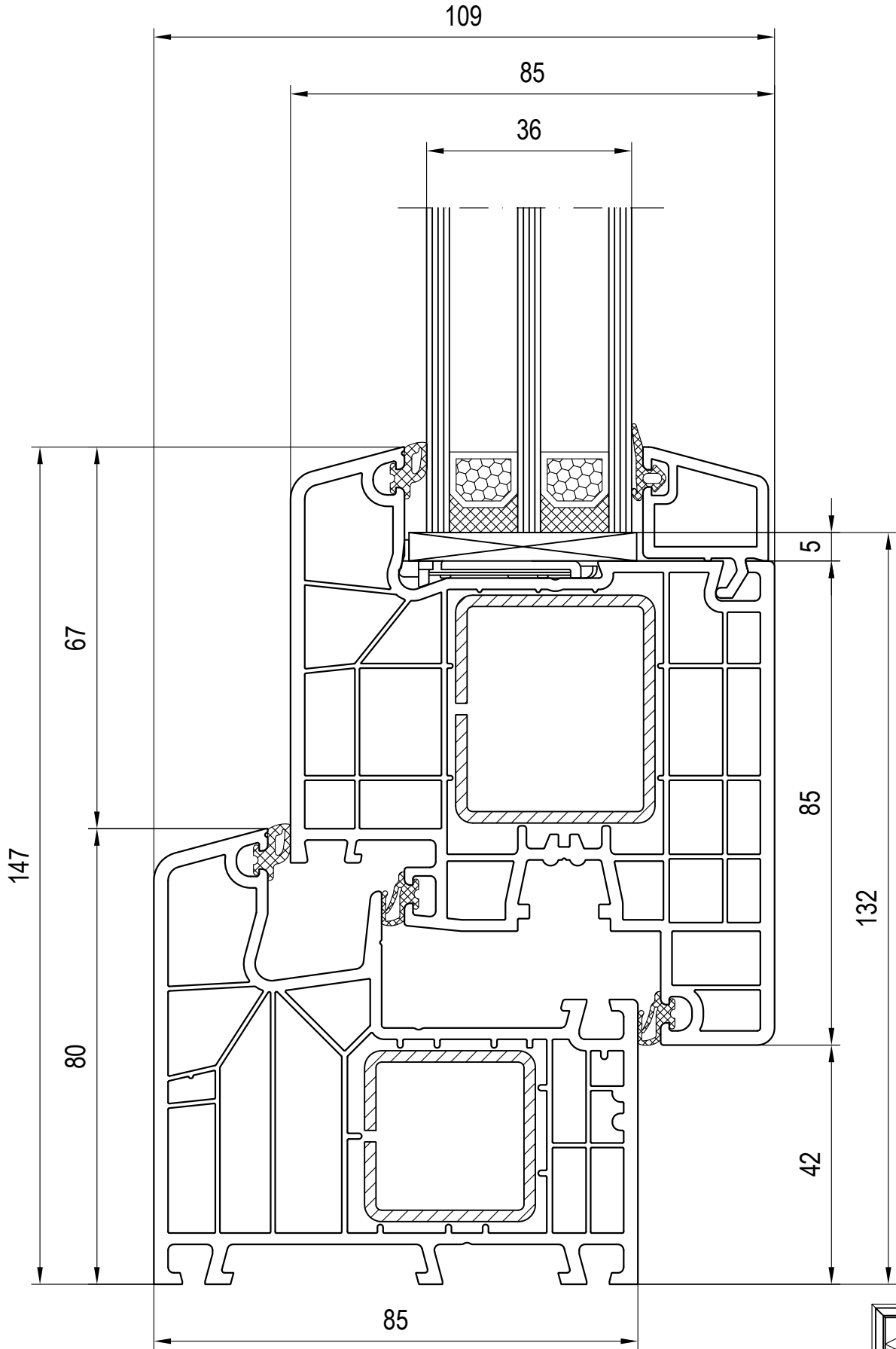

May be subject to change  
 and errors excepted!

scale: 1:1  
 03\_D\_01\_8\*

Combinations: Frame - Sash  
 Glazing Bead 120636/120666

Frame 180x05  
 Sash 180x30

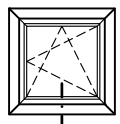
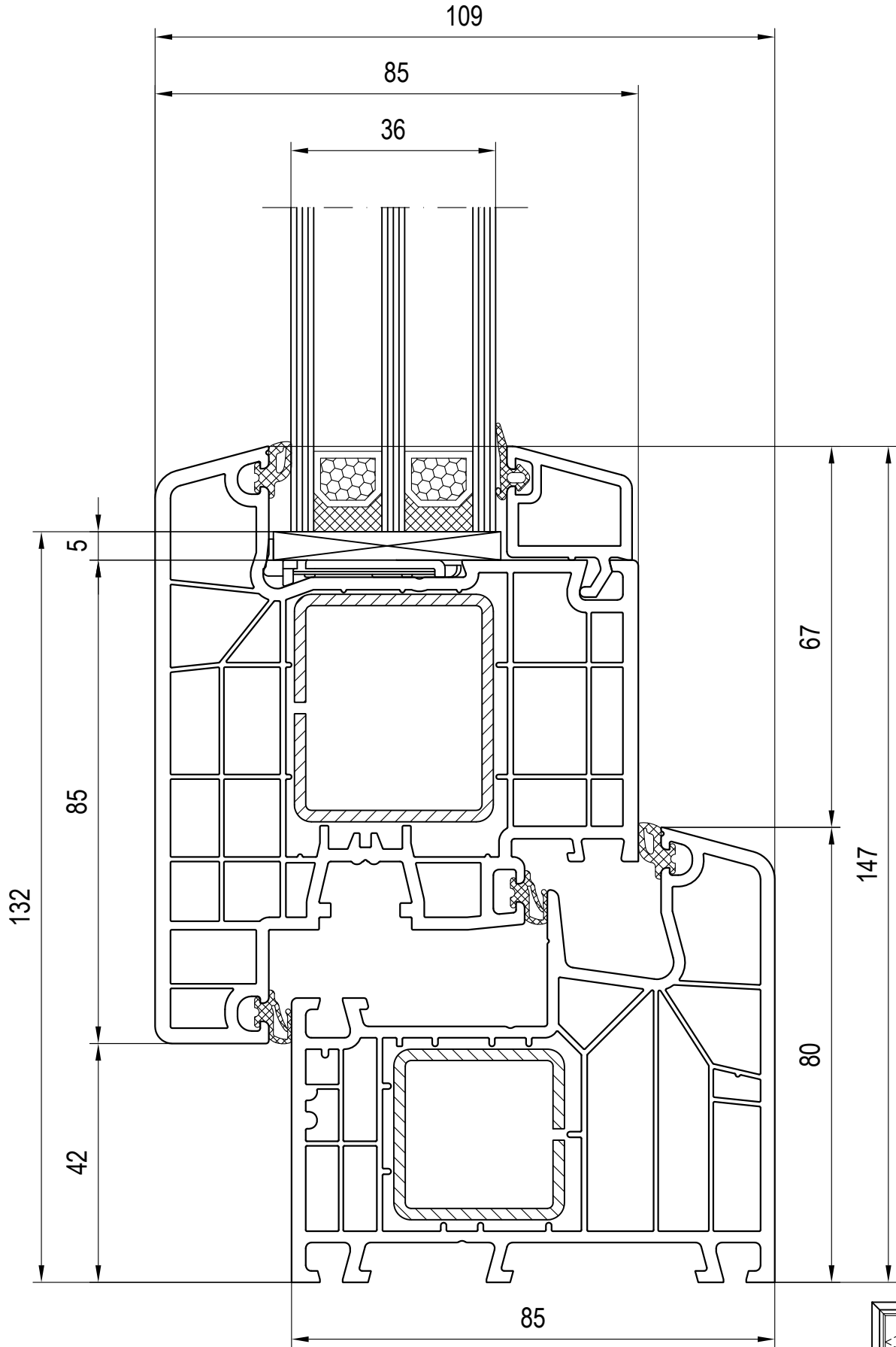

May be subject to change and errors excepted!

scale: 1:1  
 03\_D\_01\_8\*

Combinations: Frame - Sash  
 Glazing Bead 120636/120666

Frame 180x05  
 Sash 180x31

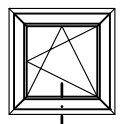
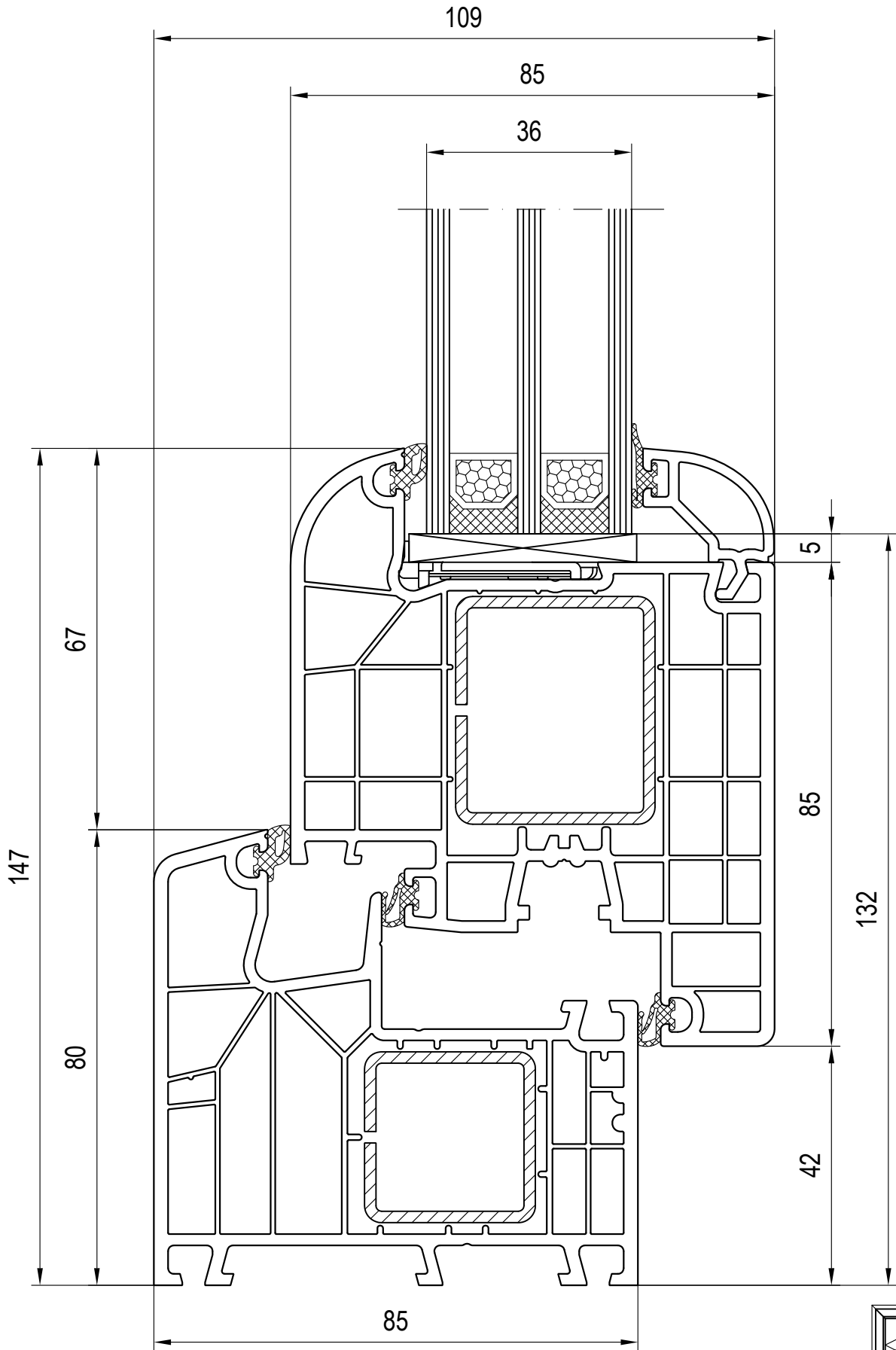

May be subject to change and errors excepted!

scale: 1:1  
03\_D\_01\_8\*

Combinations: Frame - Sash  
Glazing Bead 120650/120680

Frame 180x05  
Sash 180x32

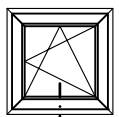
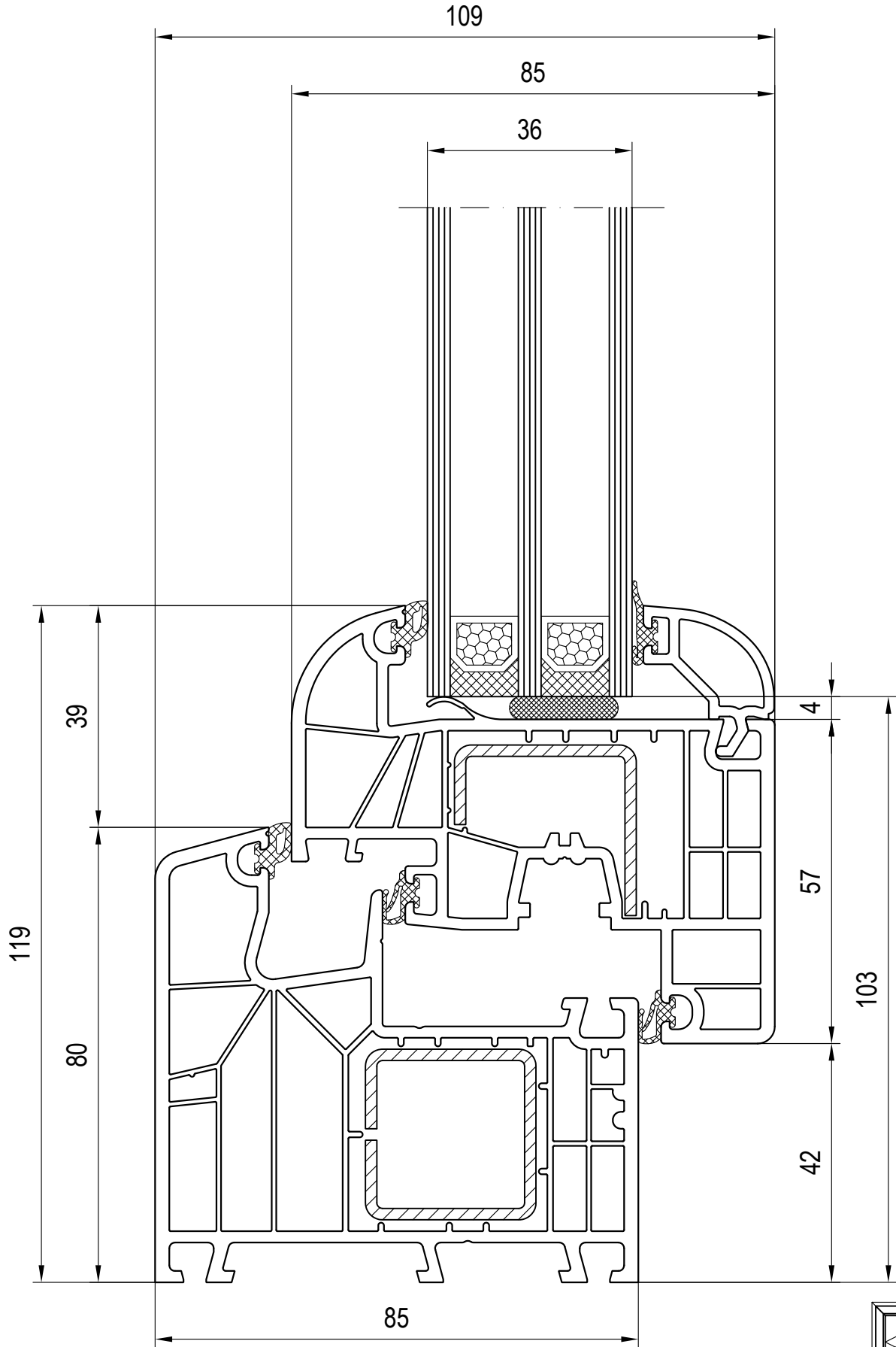

May be subject to change  
and errors excepted!

scale: 1:1  
03\_D\_01\_8\*

Combinations: Frame - Sash  
Glazing Bead 120650/120680

Frame 180x05  
Sash 180x83



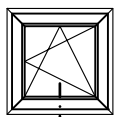
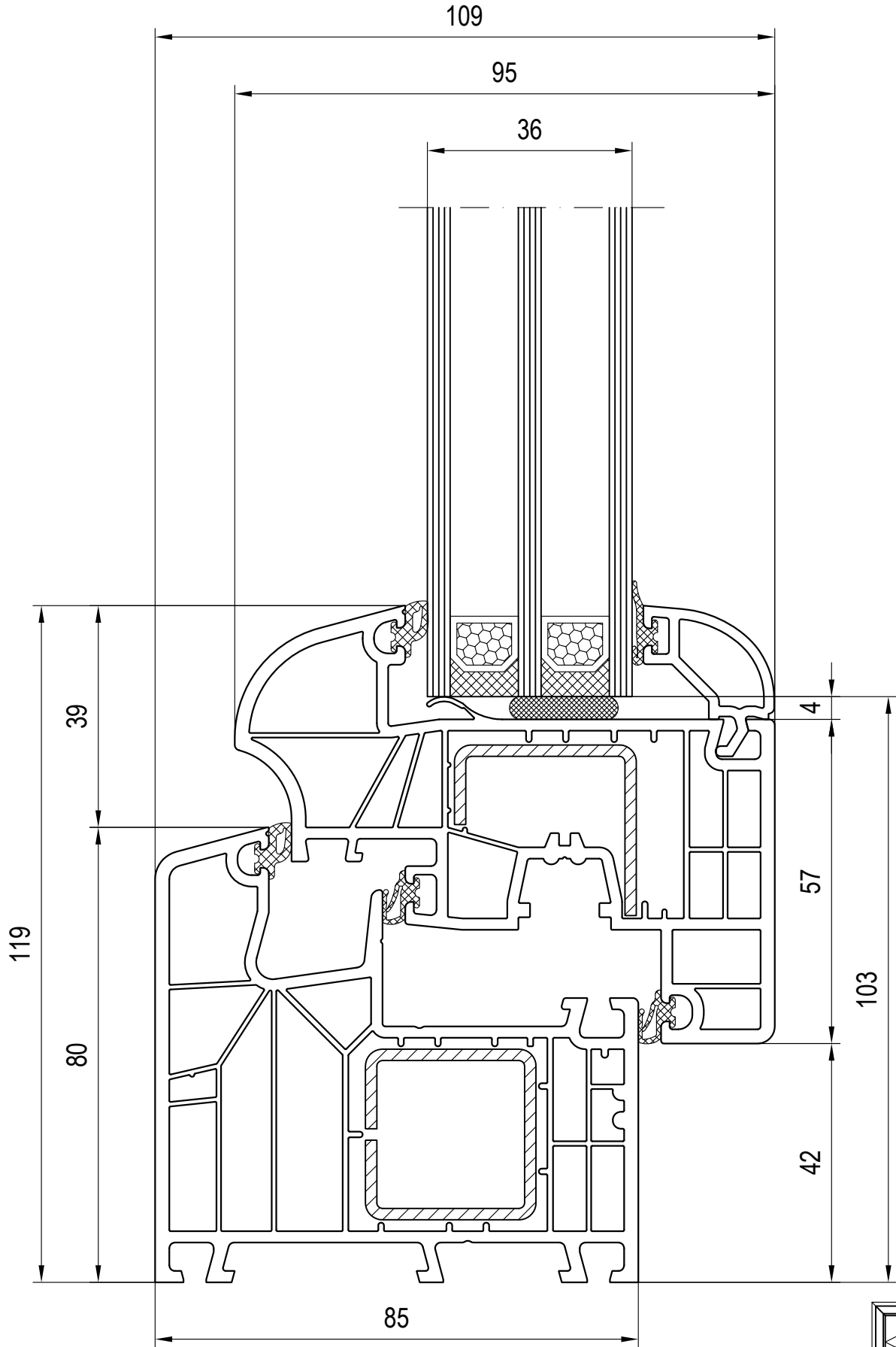

May be subject to change  
and errors excepted!

scale: 1:1  
03\_D\_01\_8\*

Combinations: Frame - Sash  
Glazing Bead 120650/120680

Frame 180x05  
Sash 180x85

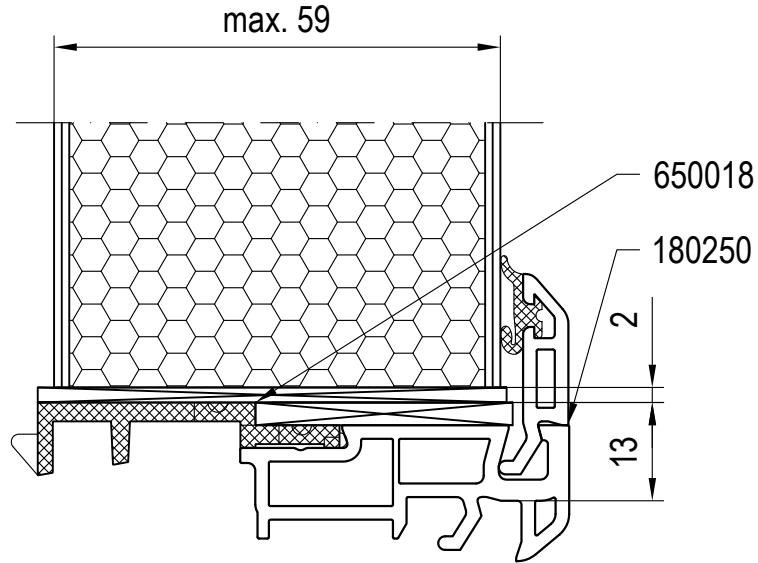

glazing bead 140631/140661 + 180250

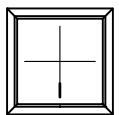
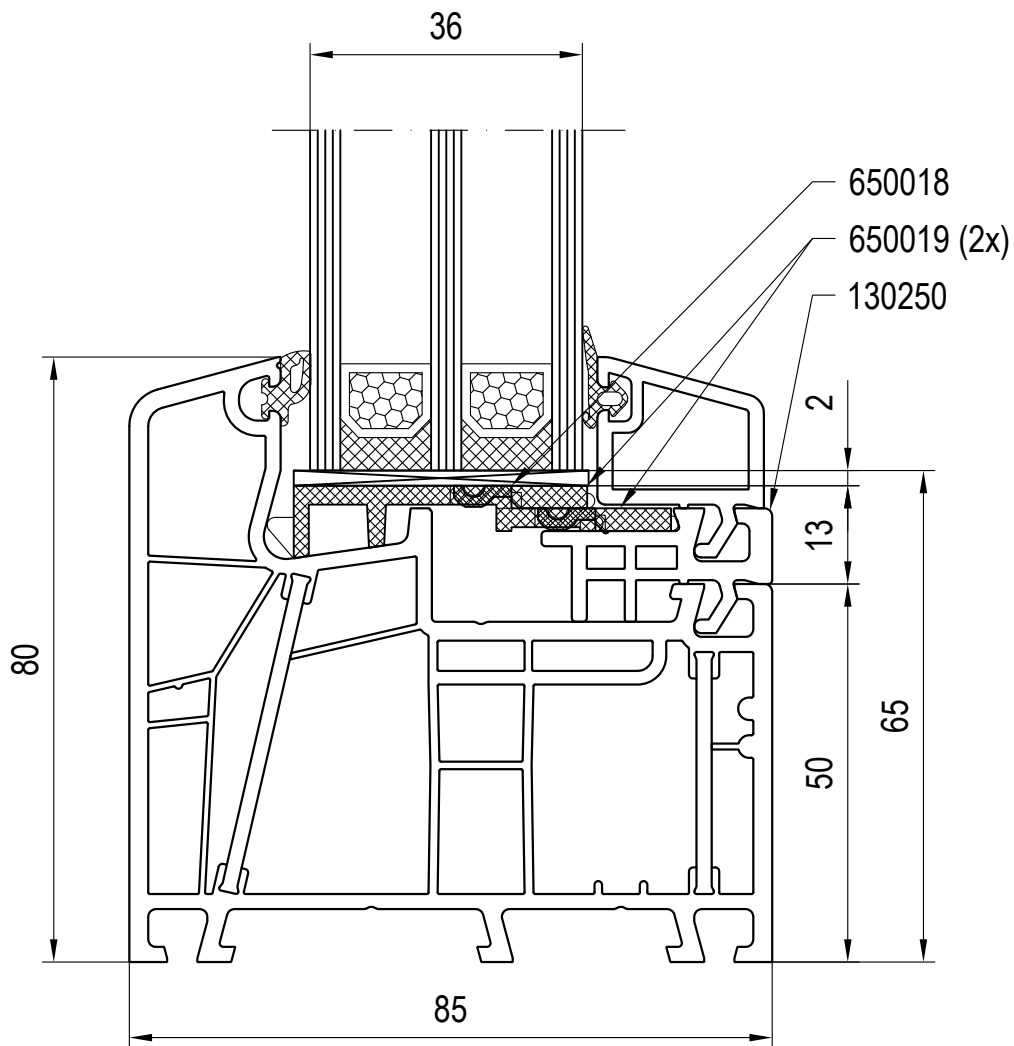

For alternatives see chapter 03 A.

May be subject to change  
and errors excepted!

scale: 1:1  
03\_E\_01\_8\*

Combinations: Frame - Fixed Glazing

Glazing Bead 120636/120666 + 130250

Frame 080x05

-

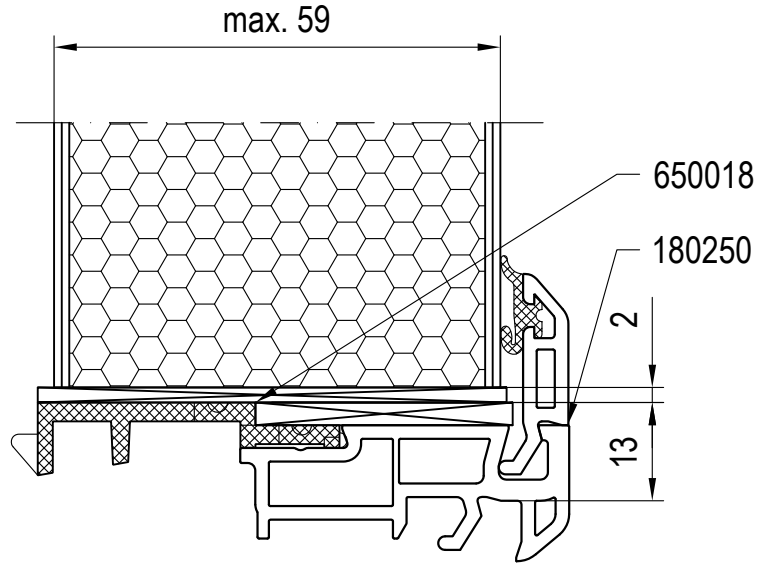

glazing bead 140631/140661 + 180250

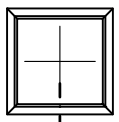
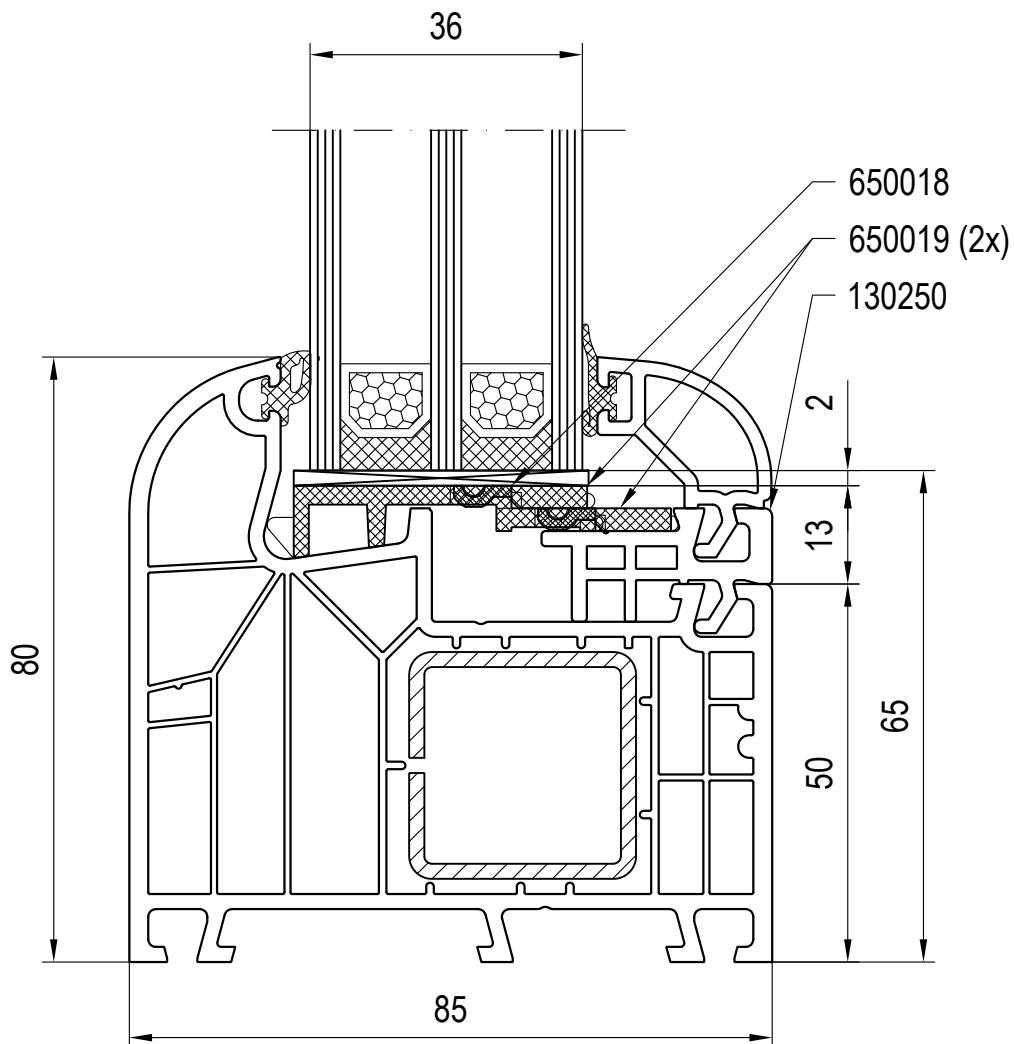

For alternatives see chapter 03 A.

May be subject to change  
and errors excepted!

scale: 1:1  
03\_E\_01\_8\*

Combinations: Frame - Fixed Glazing  
Glazing Bead 120650/120680 + 130250

Frame 180x03

-

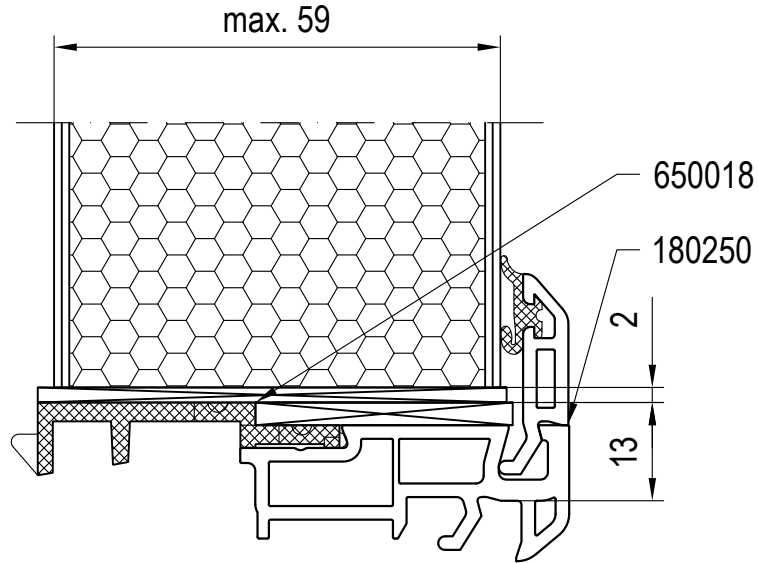

glazing bead 140631/140661 + 180250

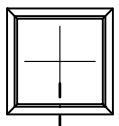
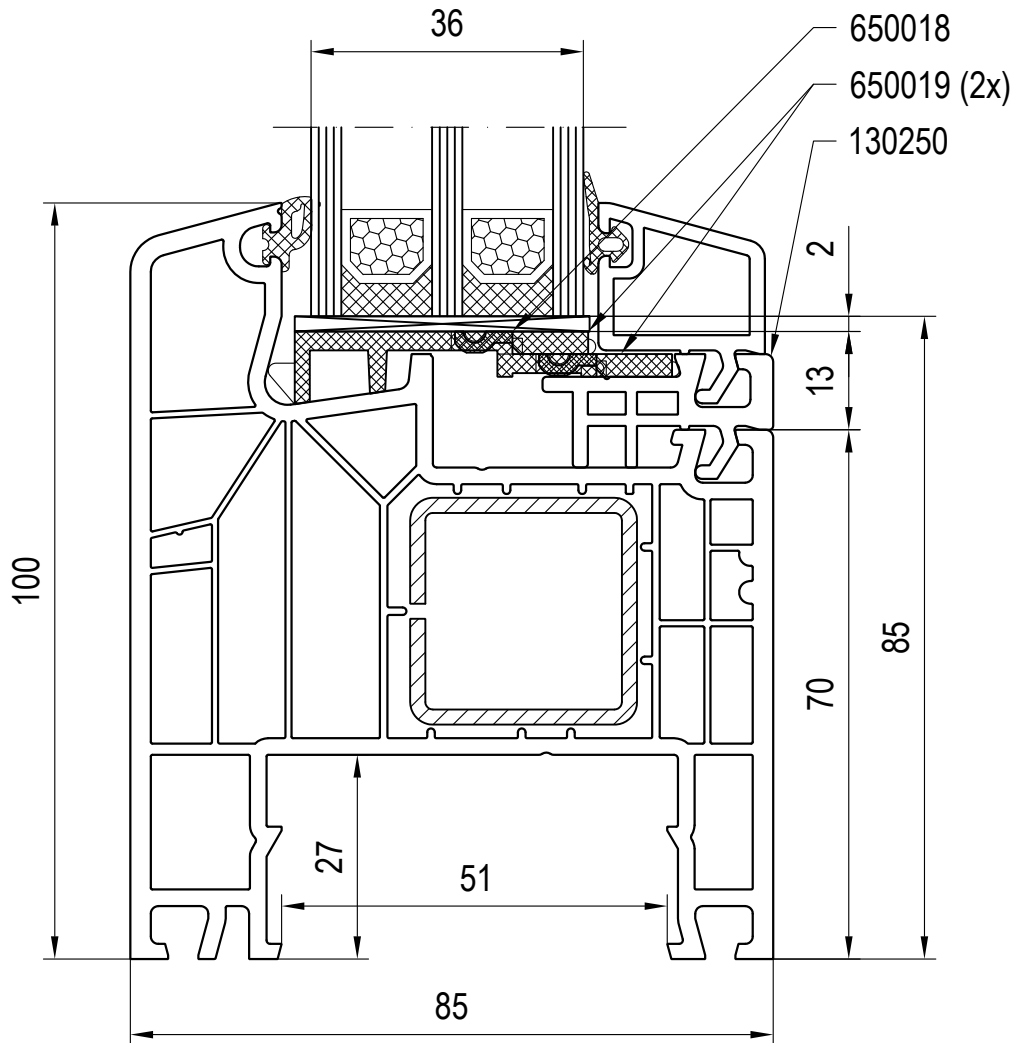

For alternatives see chapter 03 A.

May be subject to change  
and errors excepted!

scale: 1:1  
03\_E\_01\_8\*

Combinations: Frame - Fixed Glazing

Glazing Bead 120636/120666 + 130250

Frame 180x04

-

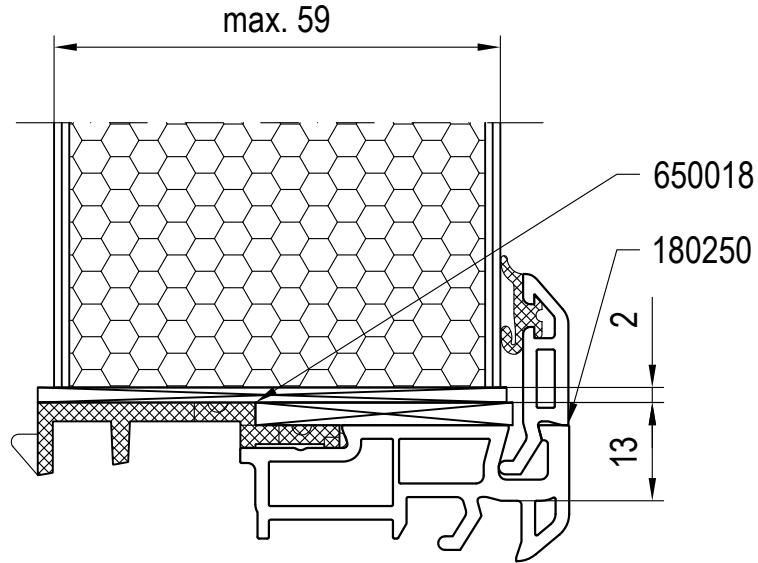

glazing bead 140631/140661 + 180250

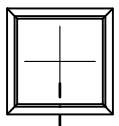
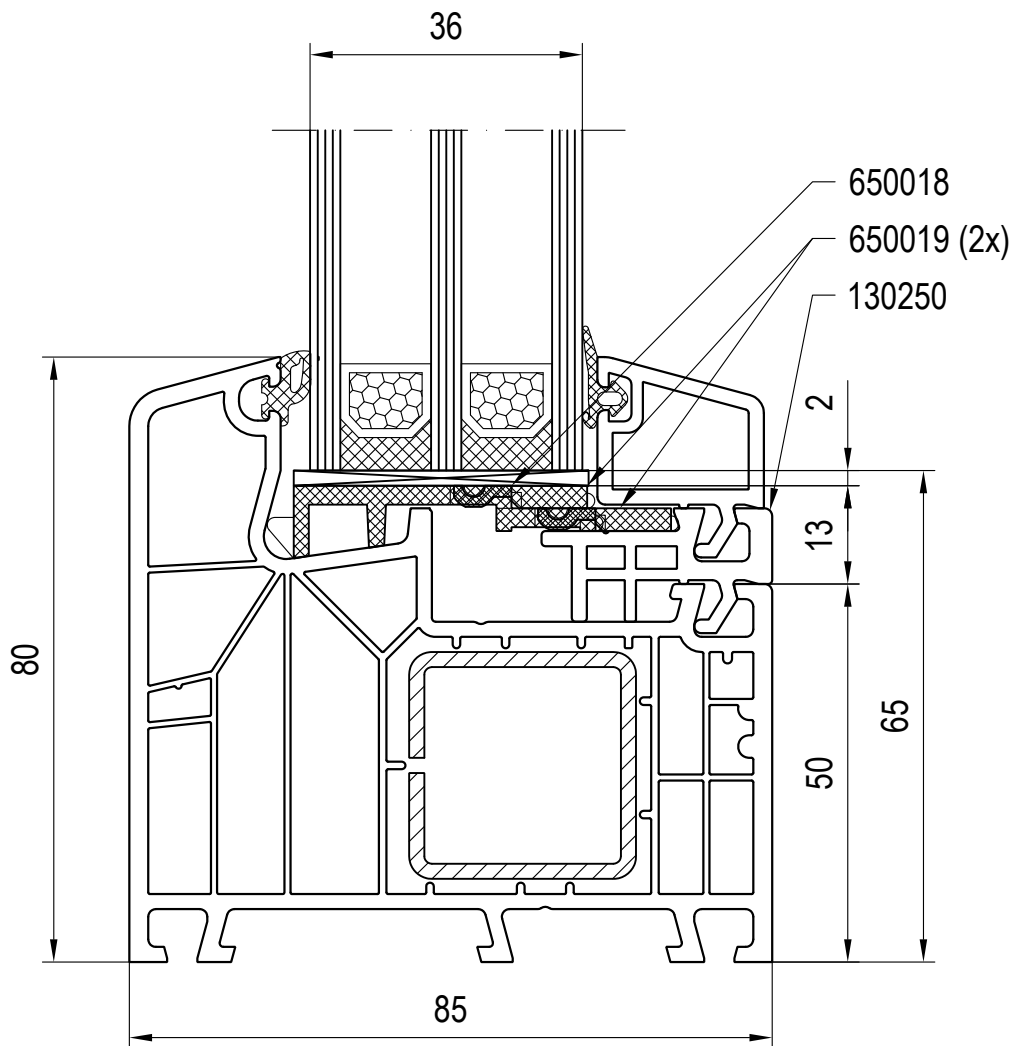

For alternatives see chapter 03 A.

May be subject to change  
and errors excepted!

scale: 1:1  
03\_E\_01\_8\*

Combinations: Frame - Fixed Glazing

Glazing Bead 120636/120666 + 130250

Frame 180x05

-

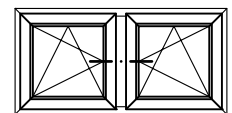
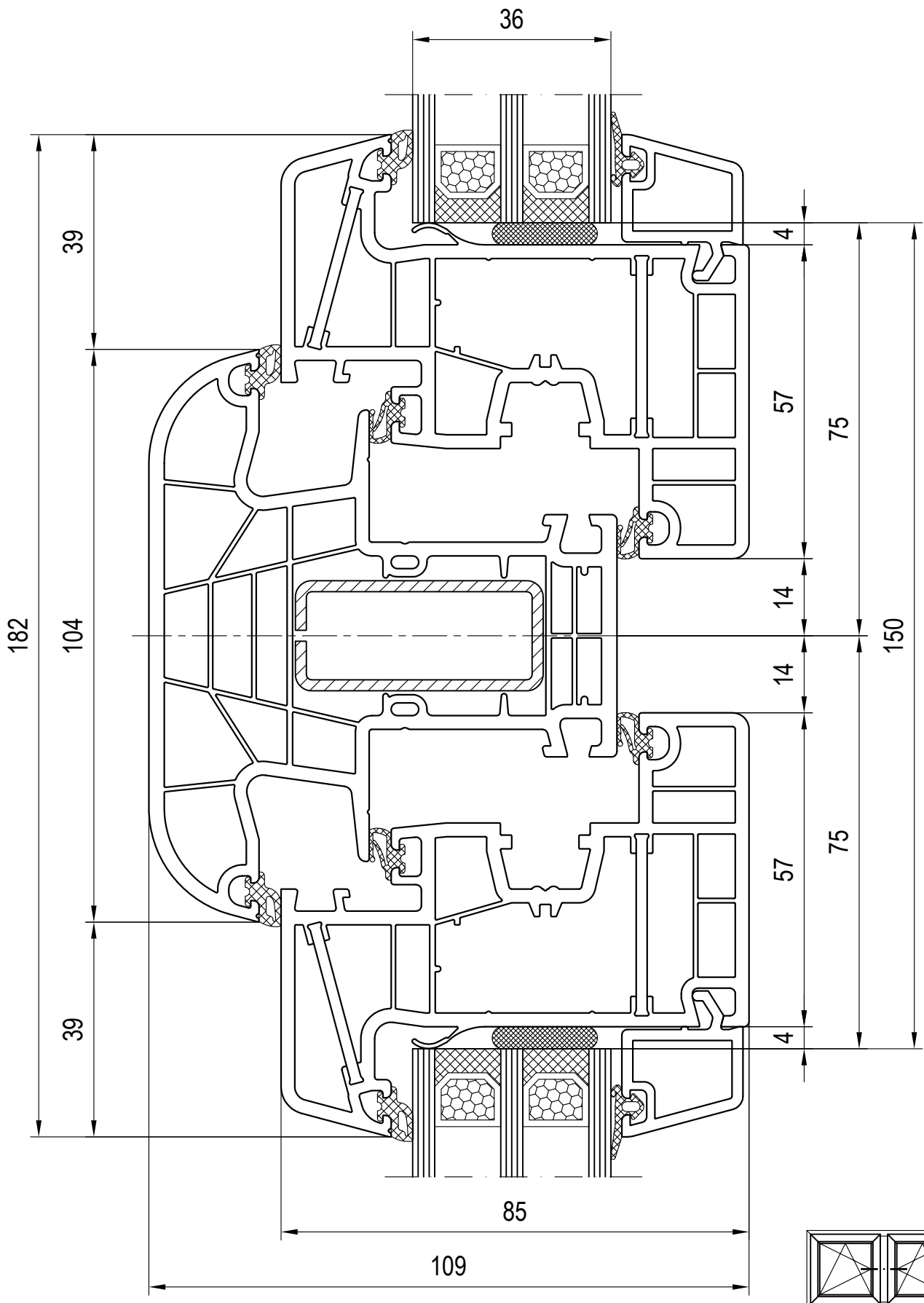

May be subject to change and errors excepted!

scale: 1:1  
03\_G\_01\_8\*

Combinations: Sash - Mullion - Sash  
Glazing Bead 120636/120666

Mullion 180x43  
Sash 080x86

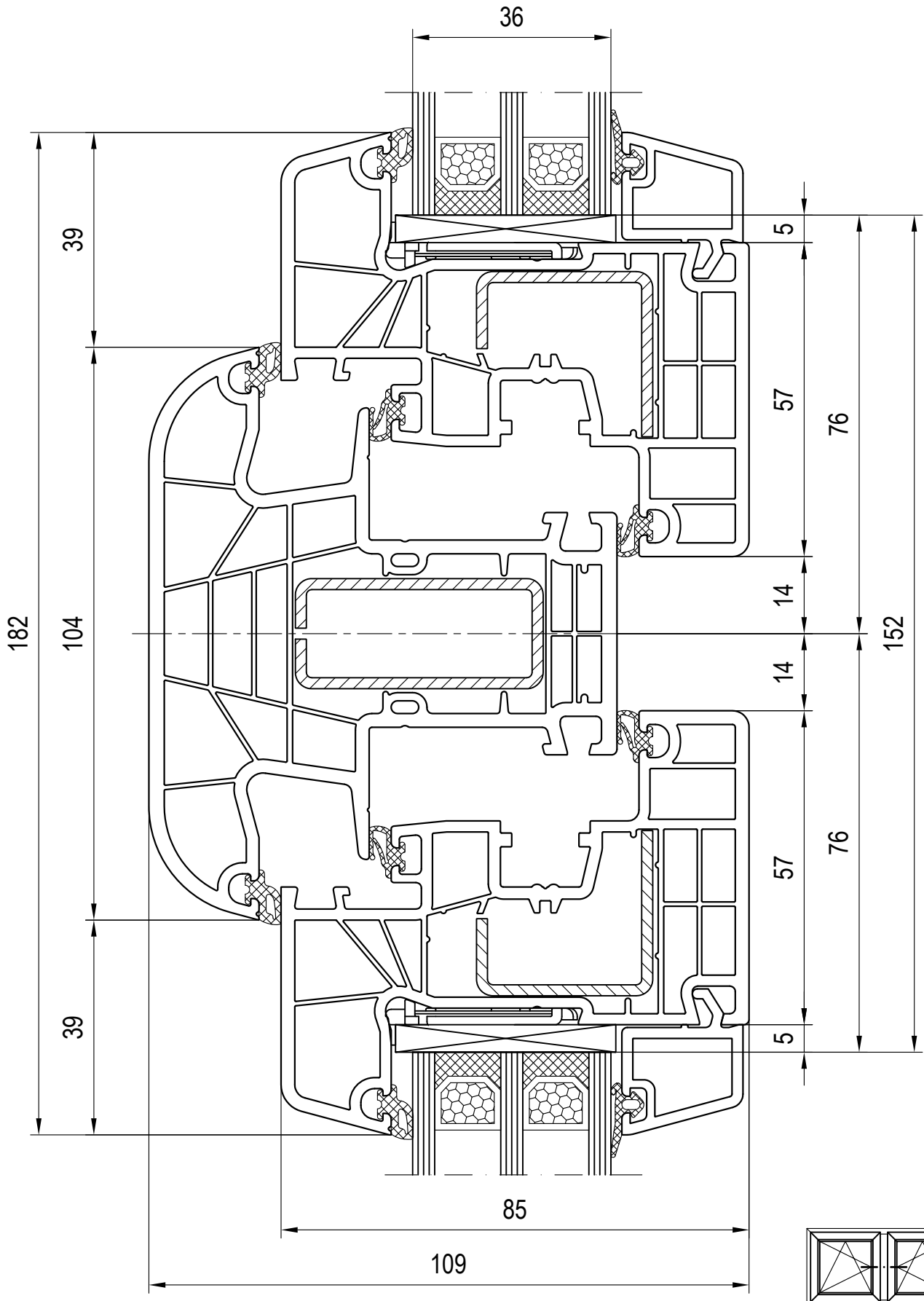

May be subject to change  
 and errors excepted!

scale: 1:1  
 03\_G\_01\_8\*

Combinations: Sash - Mullion - Sash  
 Glazing Bead 120636/120666

Mullion 180x43  
 Sash 180x20

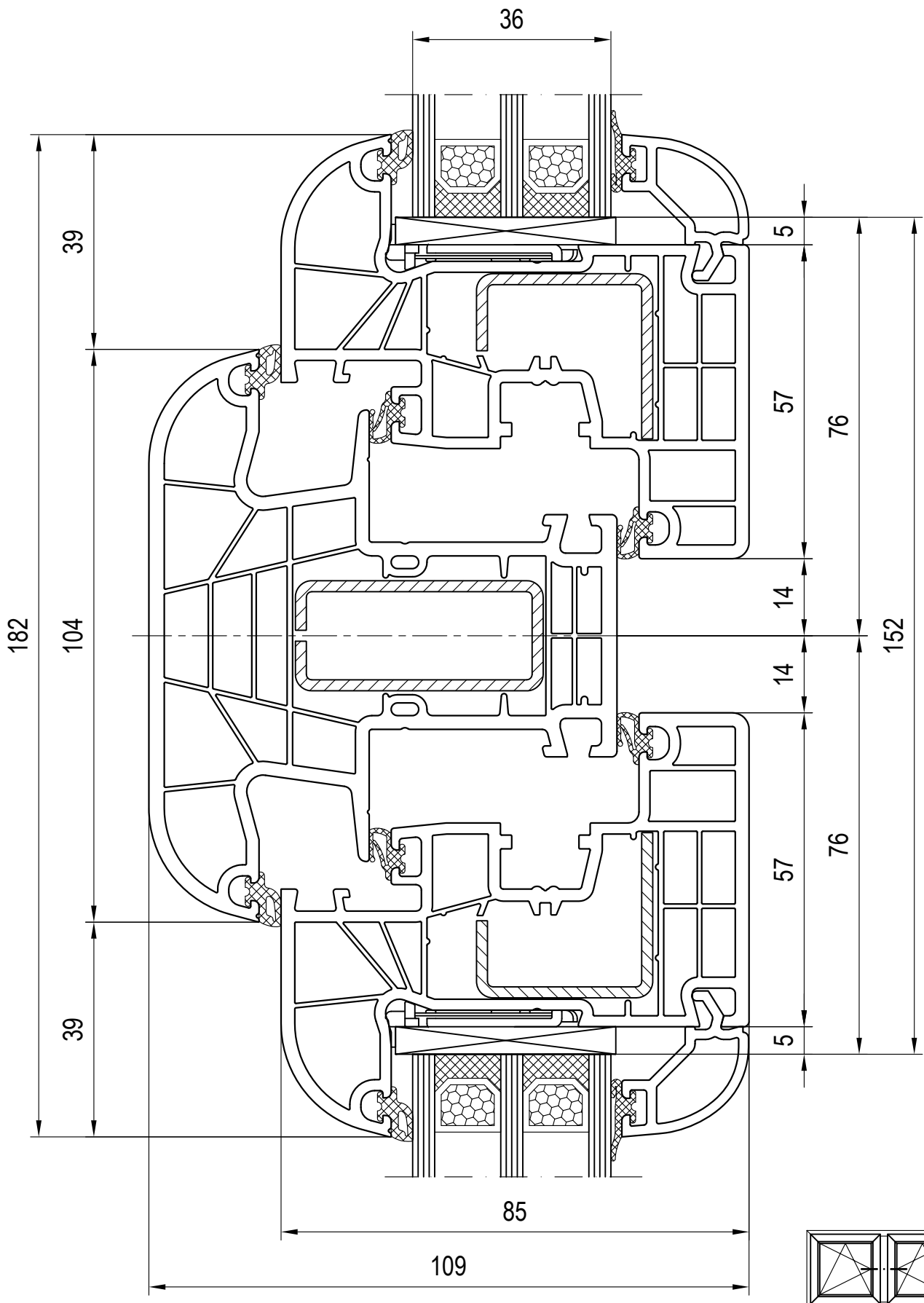

May be subject to change and errors excepted!

scale: 1:1  
03\_G\_01\_8\*

Combinations: Sash - Mullion - Sash  
Glazing Bead 120650/120680

Mullion 180x43  
Sash 180x22



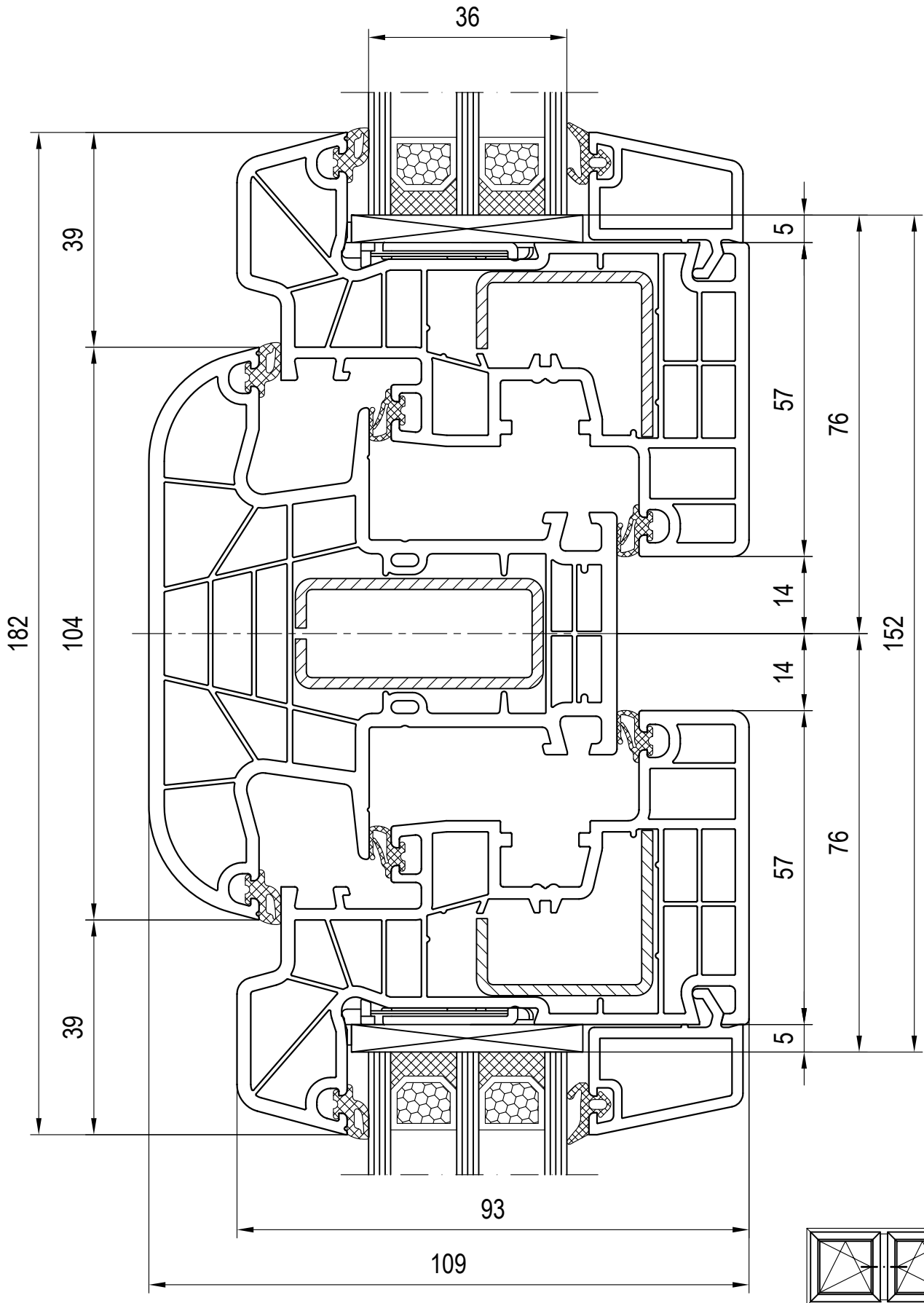

May be subject to change  
and errors excepted!

scale: 1:1  
03\_G\_01\_8\*

Combinations: Sash - Mullion - Sash  
Glazing Bead 120838/120868

Mullion 180x43  
Sash 180x26

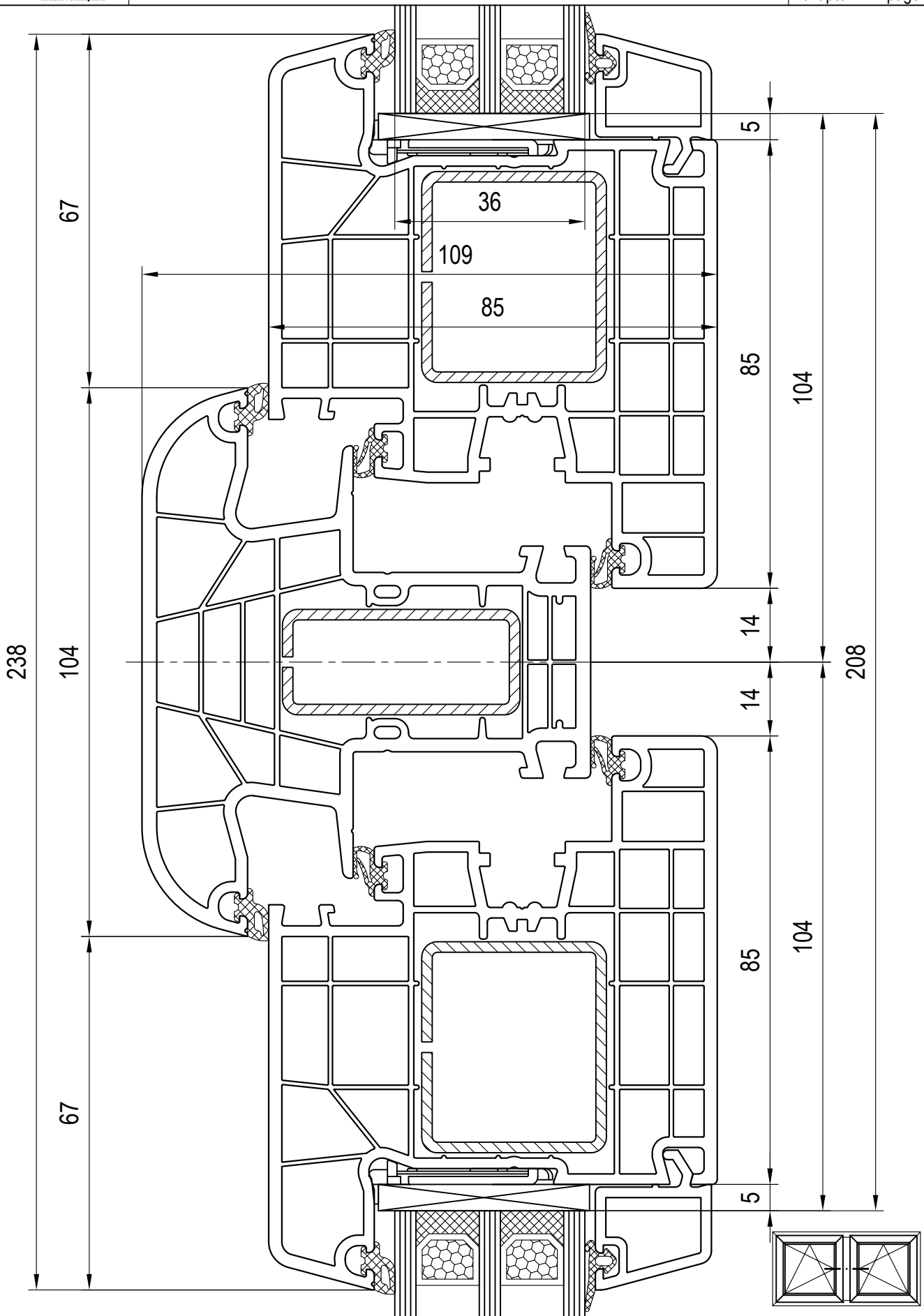

May be subject to change and errors excepted!

scale: 1:1  
03\_G\_01\_8\*

Combinations: Sash - Mullion - Sash  
Glazing Bead 120636/120666

Mullion 180x43  
Sash 180x30

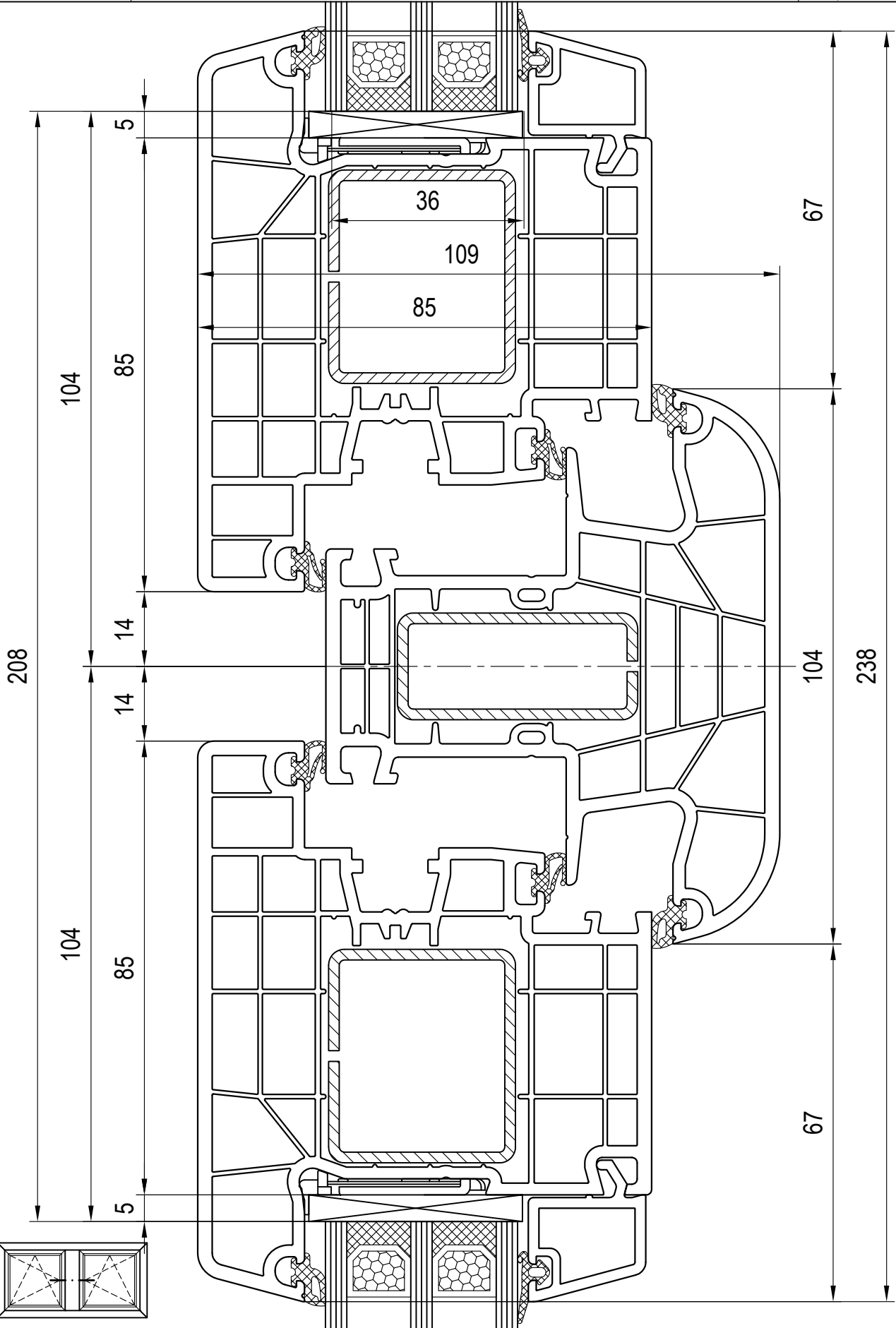

May be subject to change  
and errors excepted!

scale: 1:1  
03\_G\_01\_8\*

Combinations: Sash - Mullion - Sash  
Glazing Bead 120636/120666

Mullion 180x43  
Sash 180x31

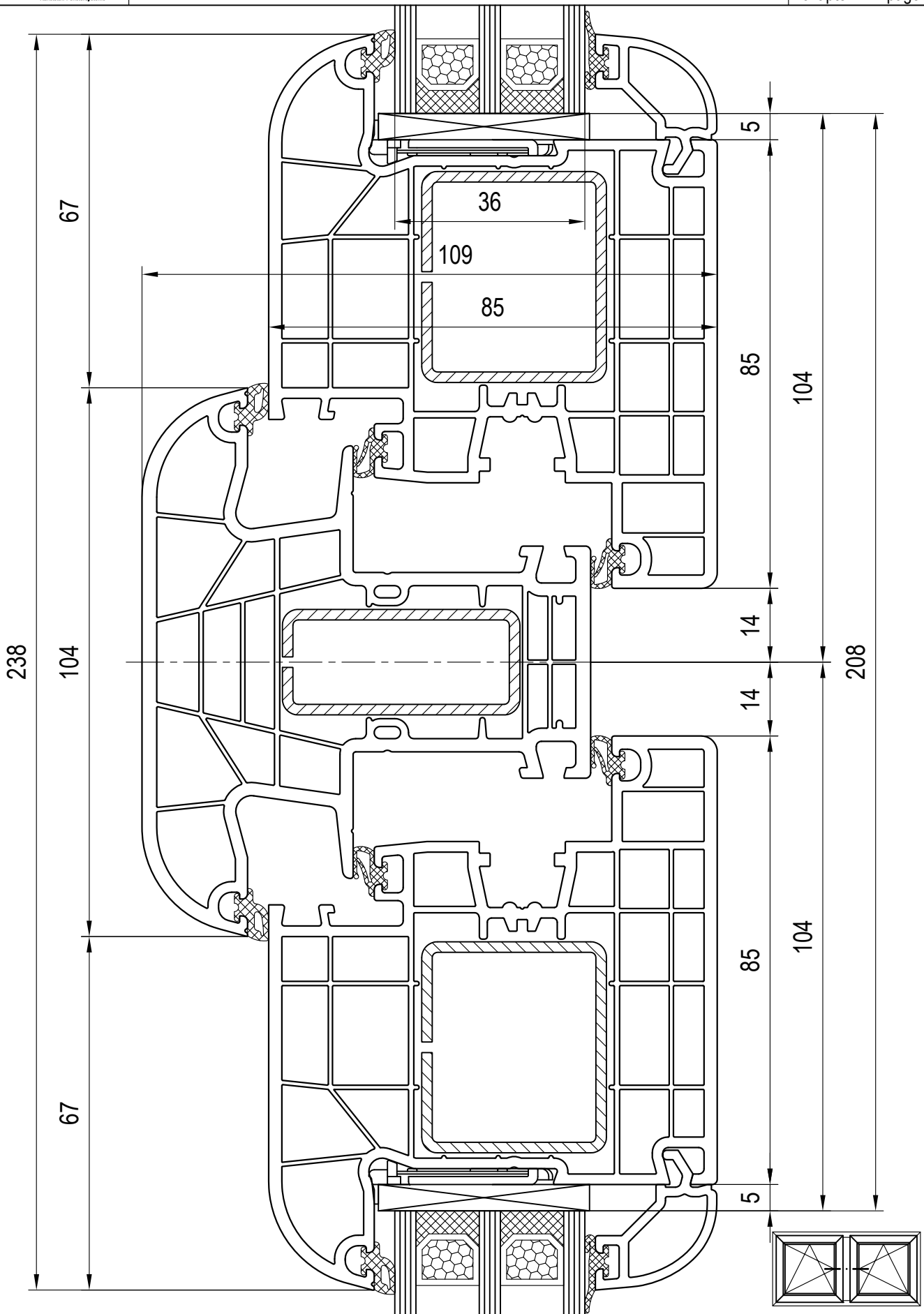

May be subject to change and errors excepted!

scale: 1:1  
03\_G\_01\_8\*

Combinations: Sash - Mullion - Sash  
Glazing Bead 120650/120680

Mullion 180x43  
Sash 180x32

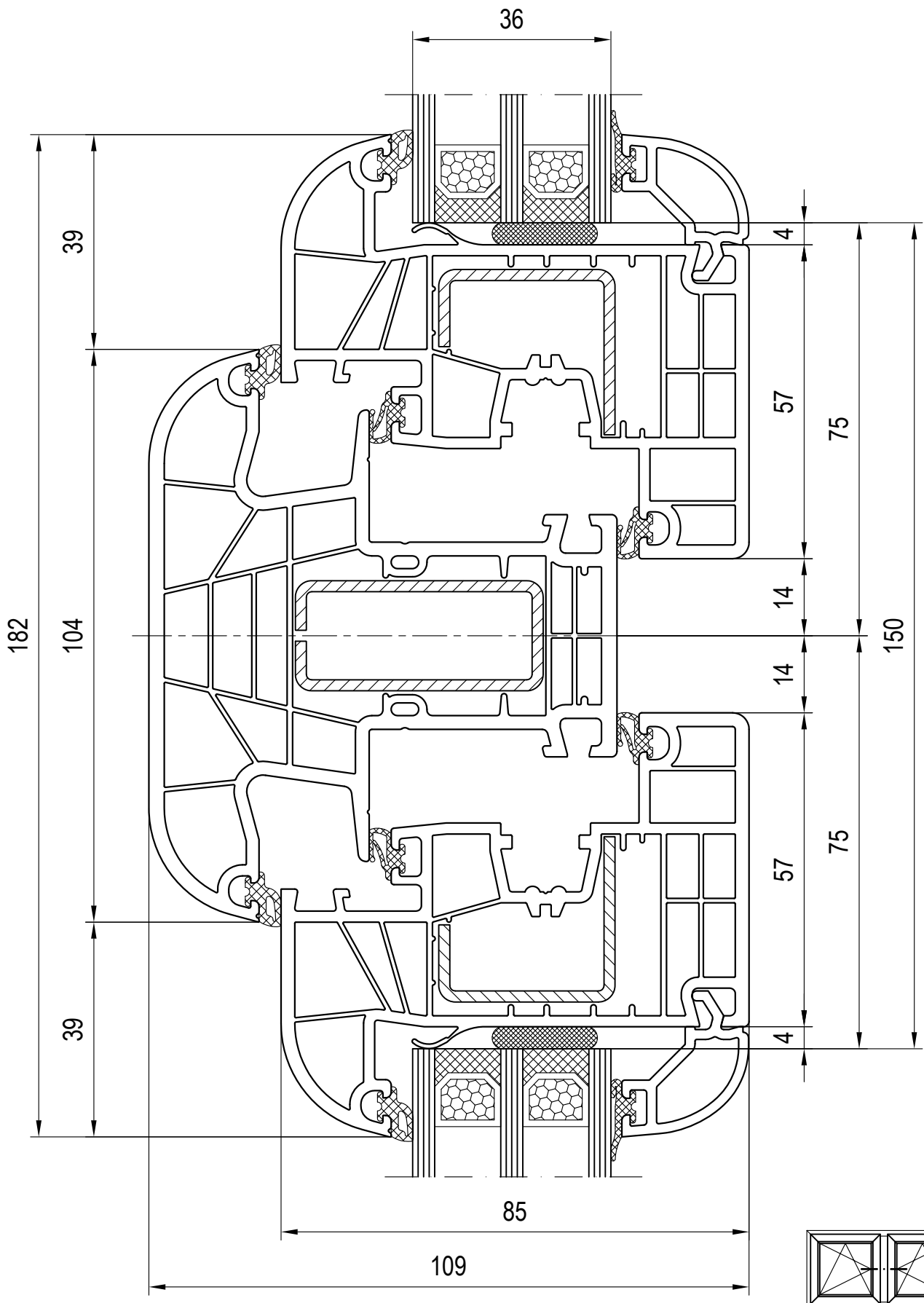

May be subject to change and errors excepted!

scale: 1:1  
 03\_G\_01\_8\*

Combinations: Sash - Mullion - Sash  
 Glazing Bead 120650/120680

Mullion 180x43  
 Sash 180x83

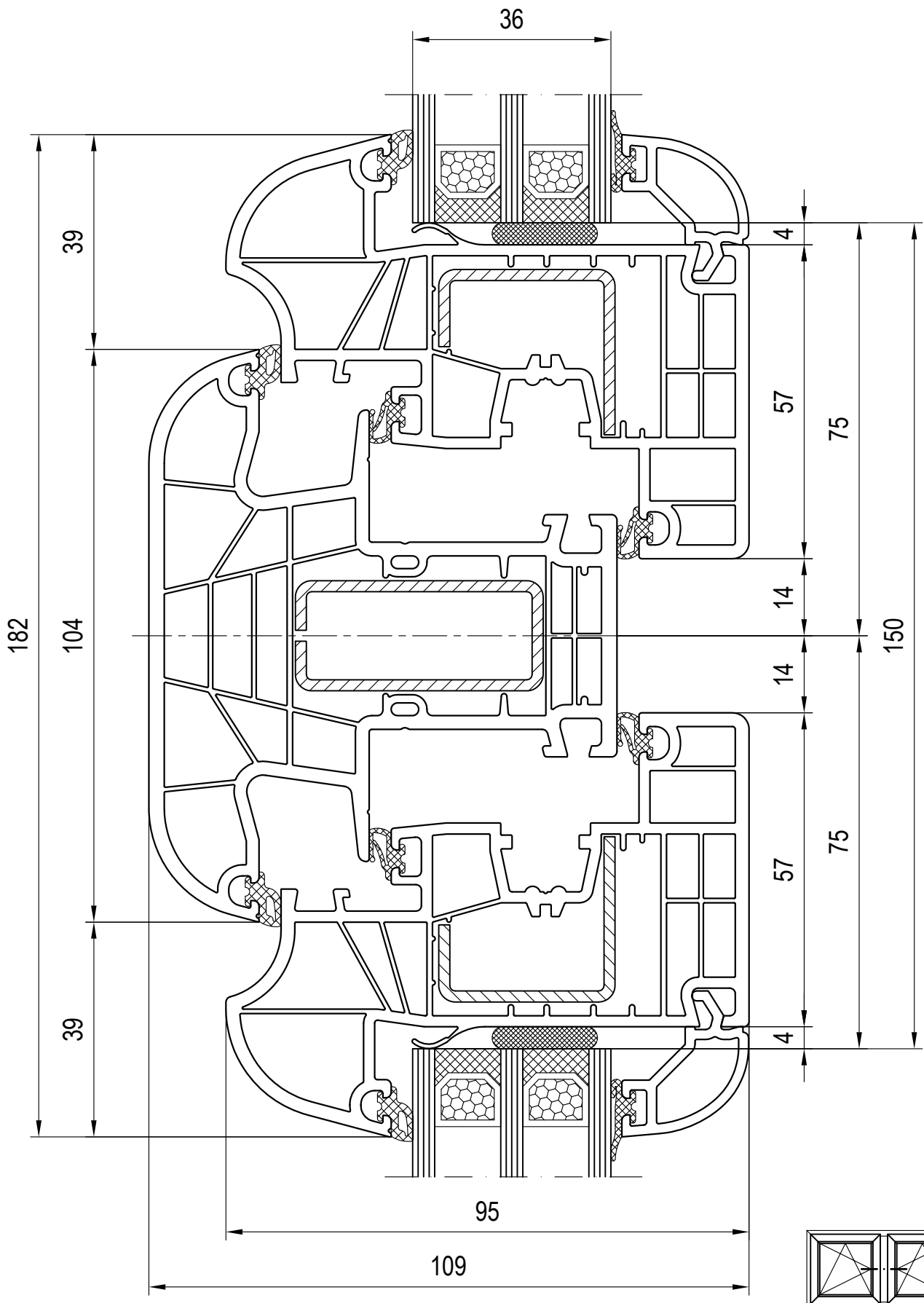

May be subject to change  
 and errors excepted!  
 scale: 1:1  
 03\_G\_01\_8\*

Combinations: Sash - Mullion - Sash  
 Glazing Bead 120650/120680

Mullion 180x43  
 Sash 180x85

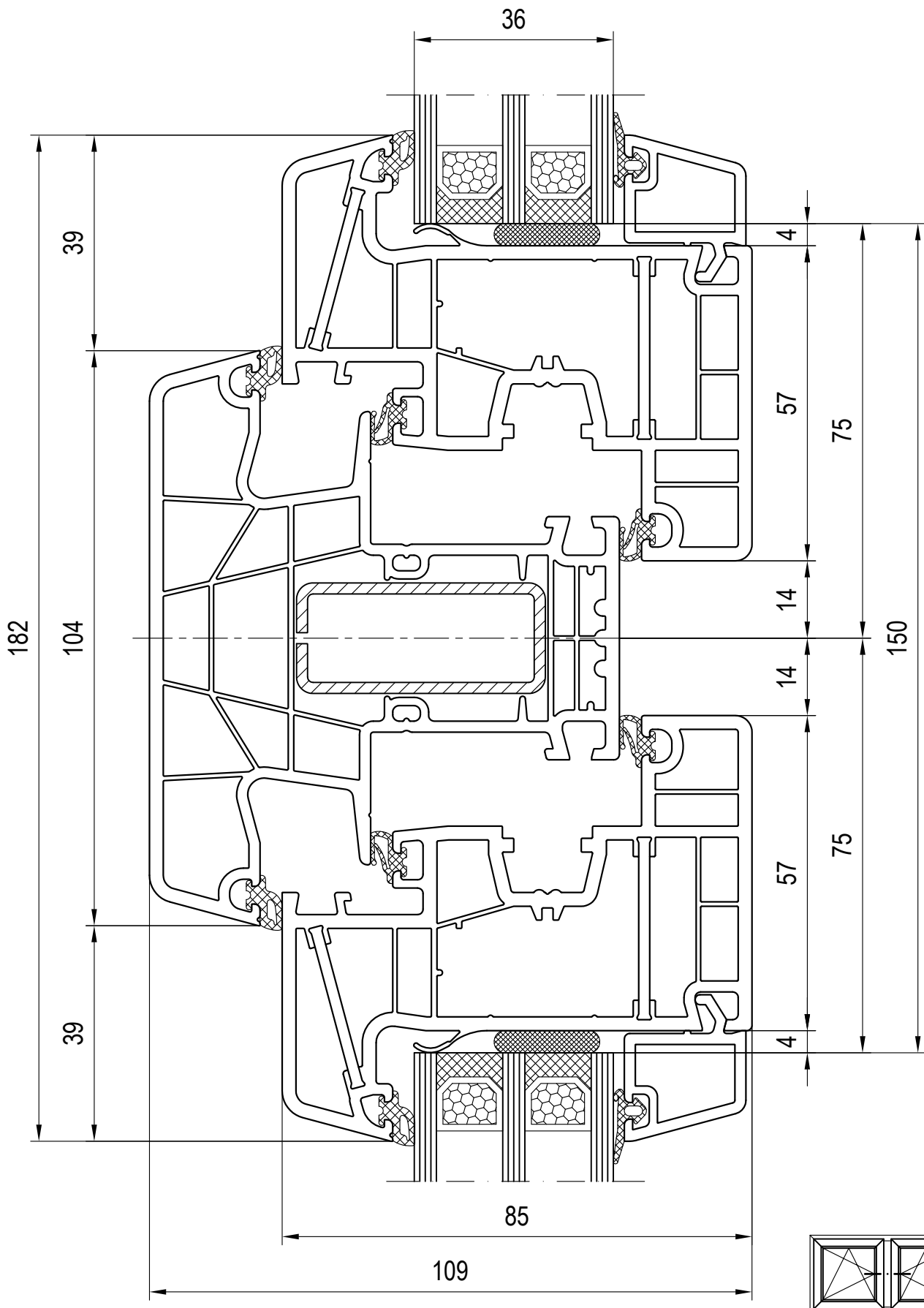

May be subject to change  
and errors excepted!

scale: 1:1  
03\_G\_01\_8\*

Combinations: Sash - Mullion - Sash  
Glazing Bead 120636/120666

Mullion 180x44  
Sash 080x86

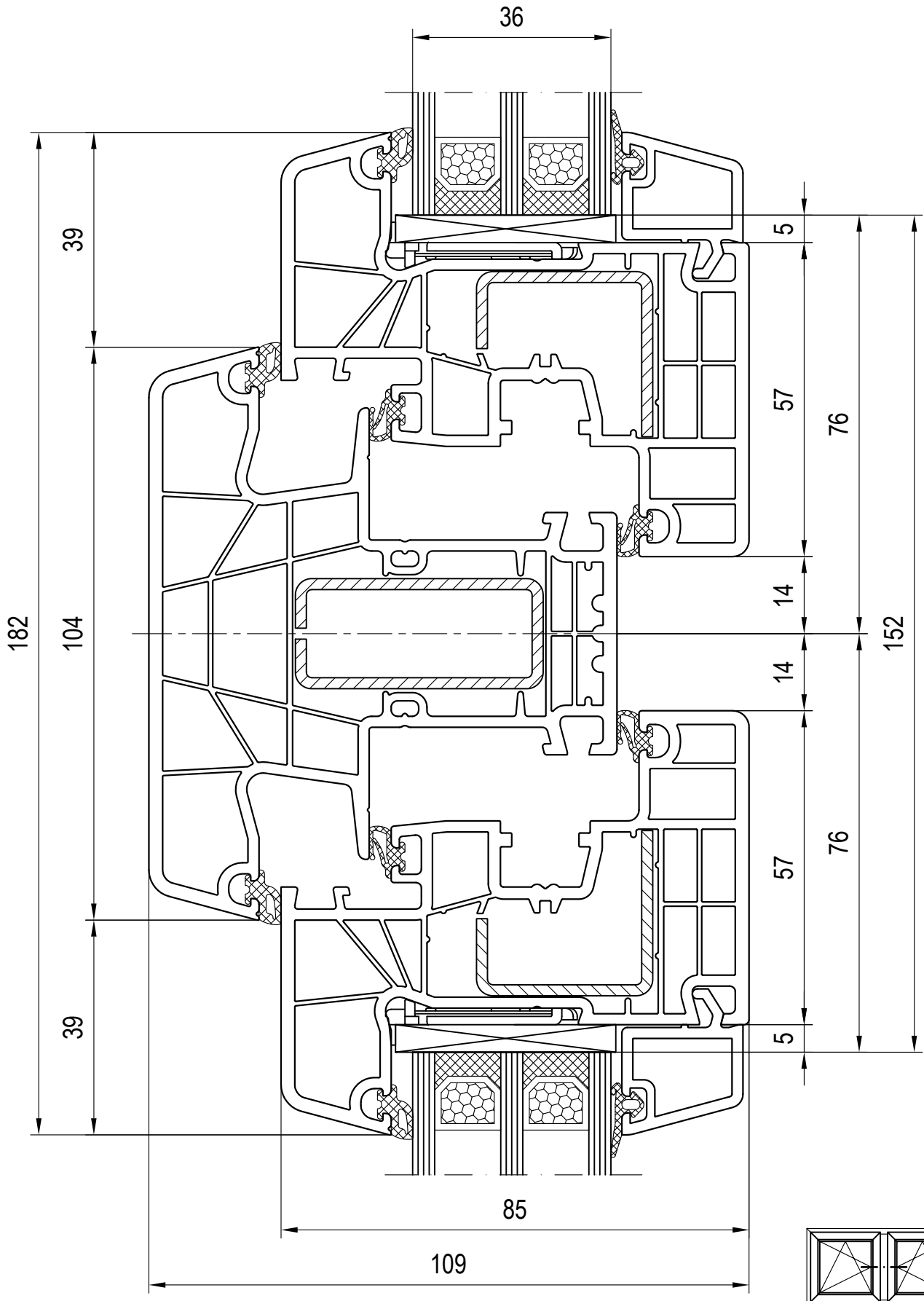

May be subject to change  
and errors excepted!

scale: 1:1  
03\_G\_01\_8\*

Combinations: Sash - Mullion - Sash  
Glazing Bead 120636/120666

Mullion 180x44  
Sash 180x20



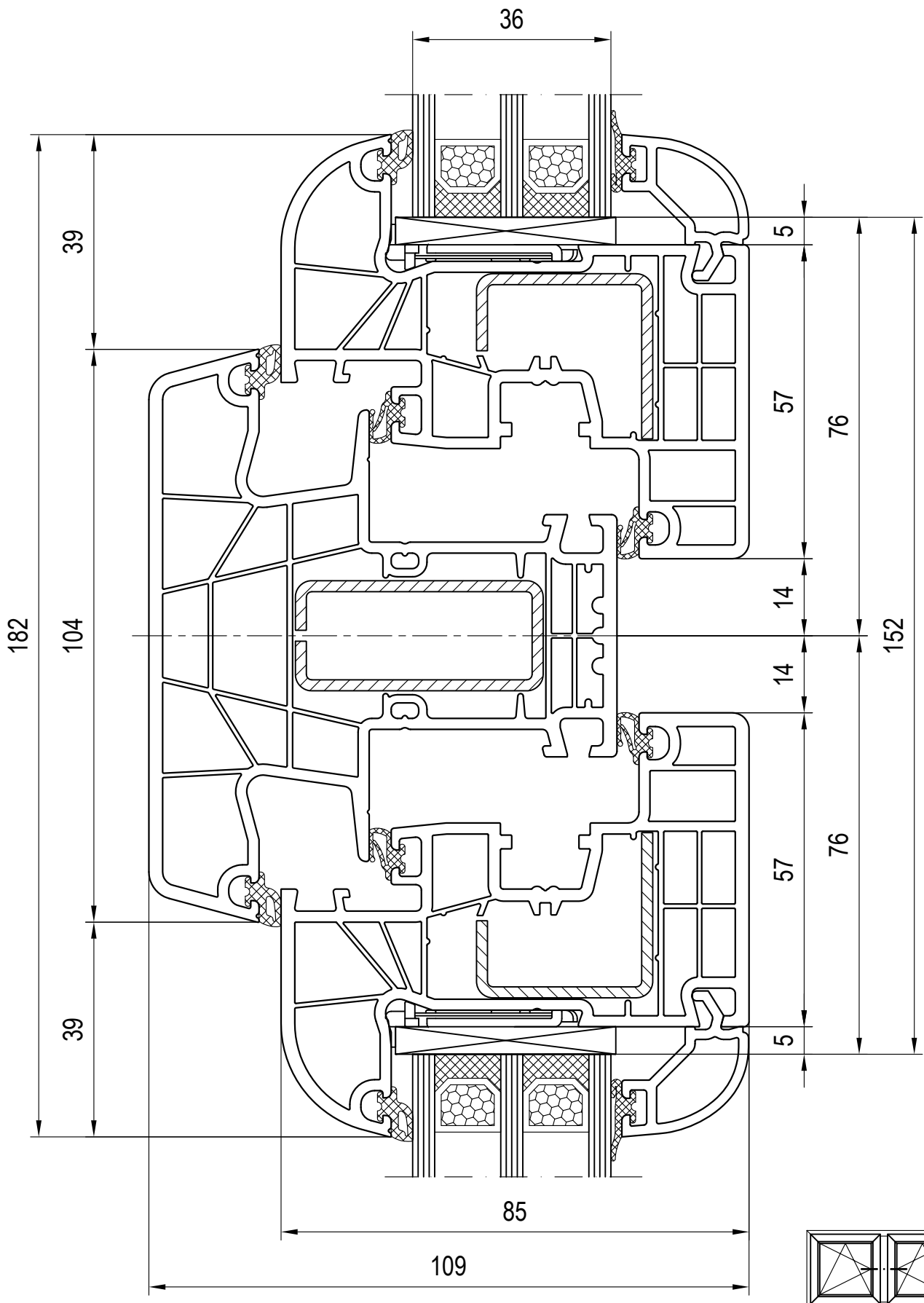

May be subject to change and errors excepted!

scale: 1:1  
 03\_G\_01\_8\*

Combinations: Sash - Mullion - Sash  
 Glazing Bead 120650/120680

Mullion 180x44  
 Sash 180x22

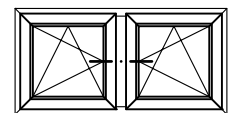
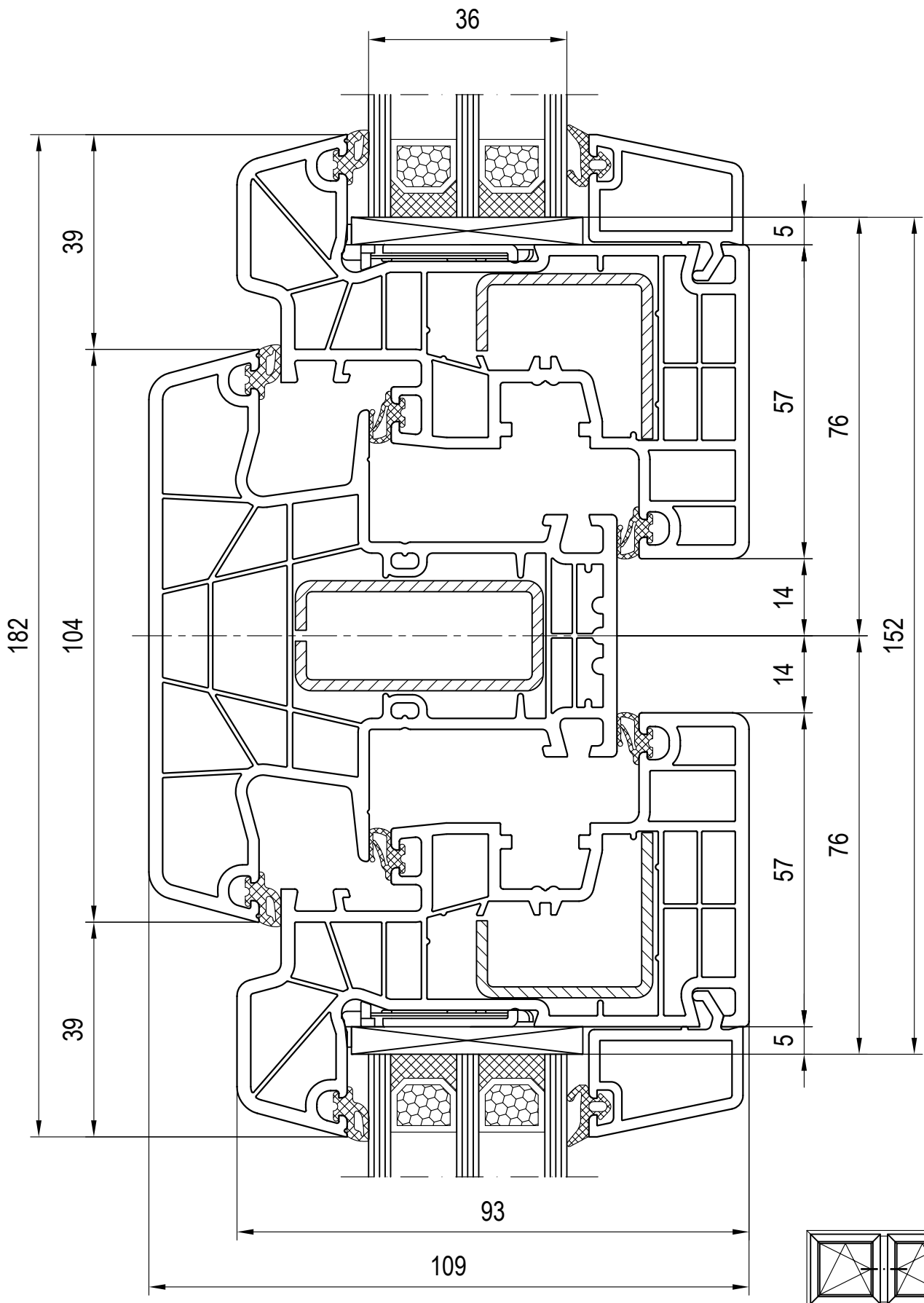

May be subject to change and errors excepted!

scale: 1:1  
03\_G\_01\_8\*

Combinations: Sash - Mullion - Sash  
Glazing Bead 120838/120868

Mullion 180x44  
Sash 180x26

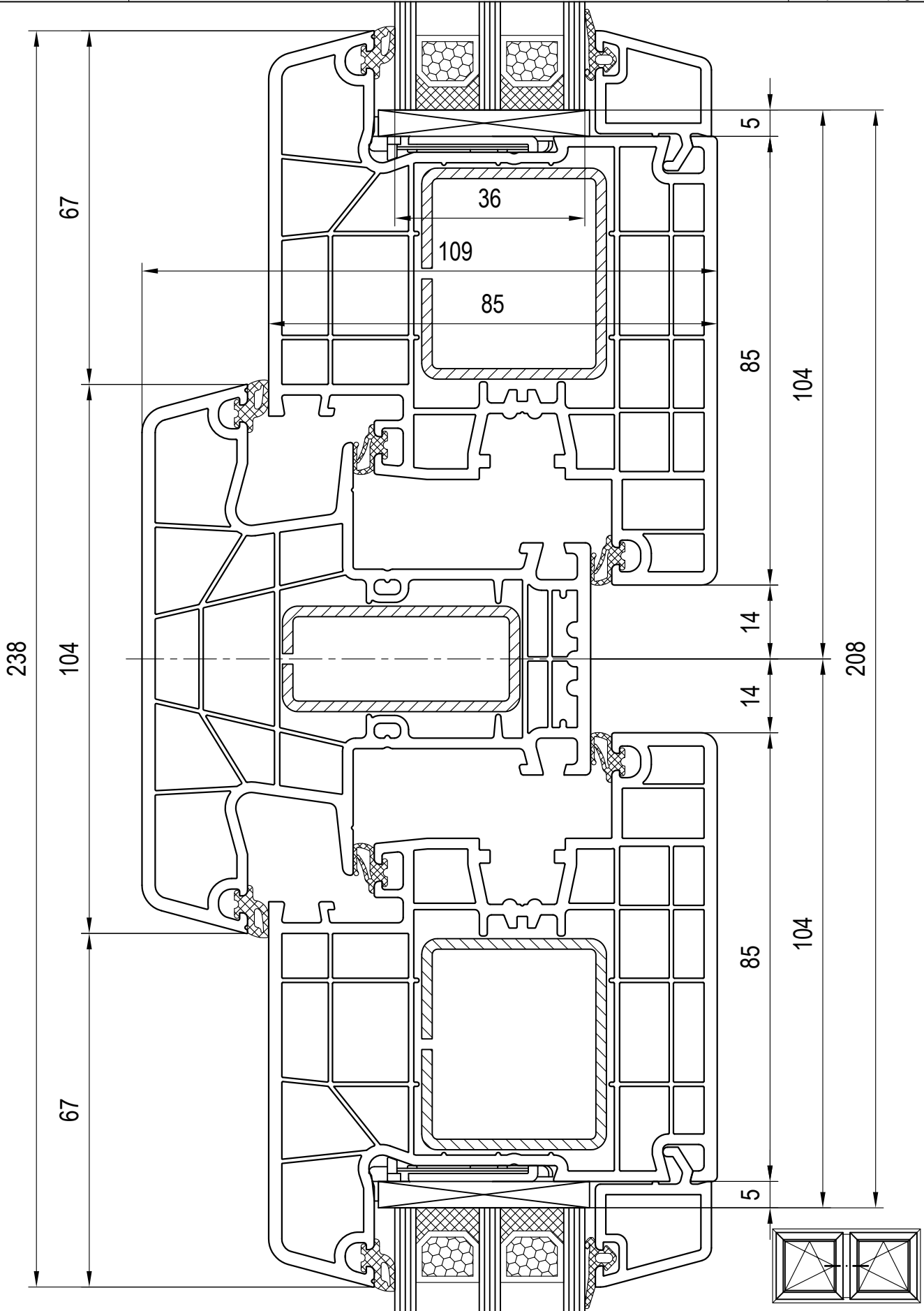

May be subject to change and errors excepted!

scale: 1:1  
03\_G\_01\_8\*

Combinations: Sash - Mullion - Sash  
Glazing Bead 120636/120666

Mullion 180x44  
Sash 180x30

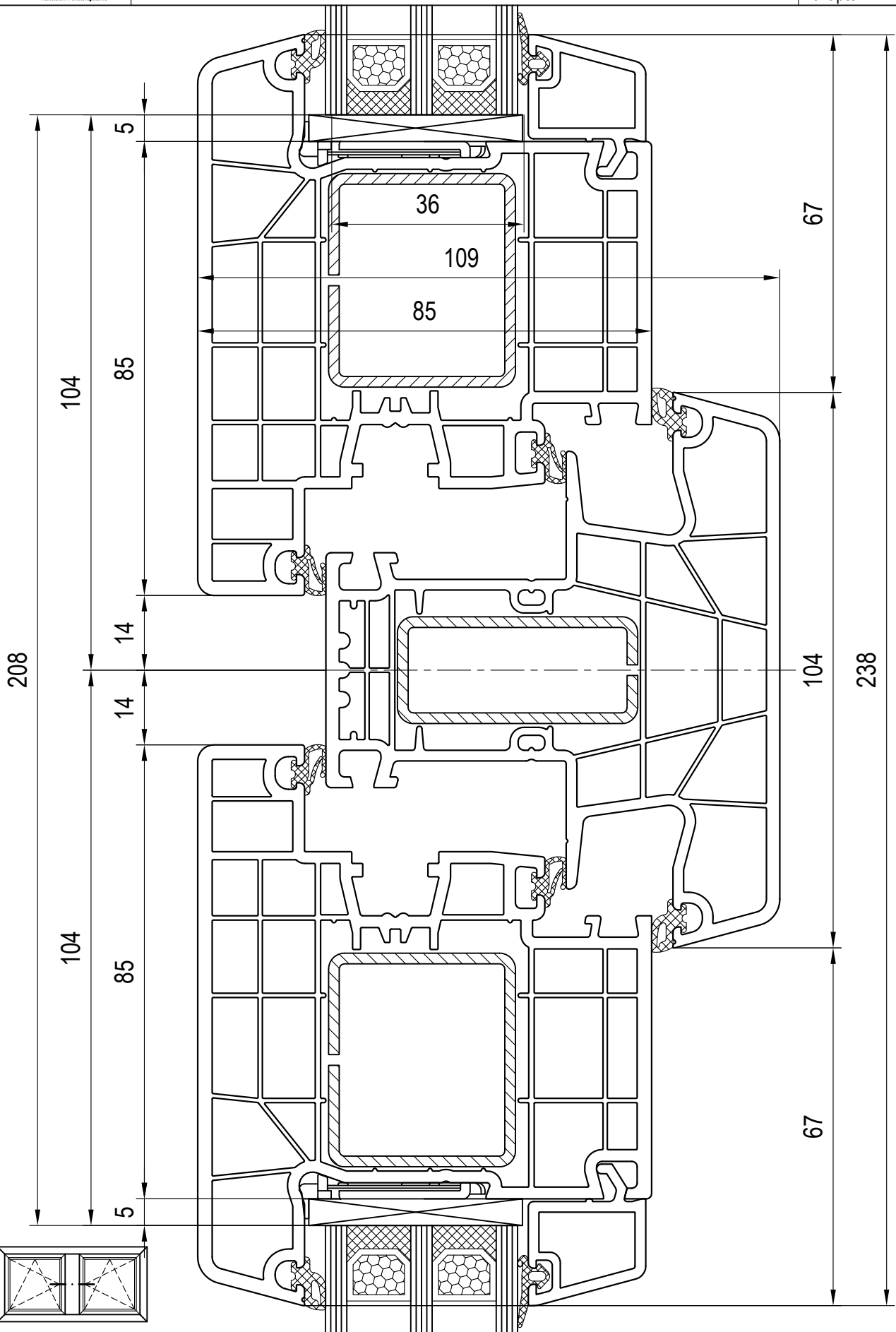

May be subject to change  
and errors excepted!

scale: 1:1  
03\_G\_01\_8\*

Combinations: Sash - Mullion - Sash  
Glazing Bead 120636/120666

Mullion 180x44  
Sash 180x31

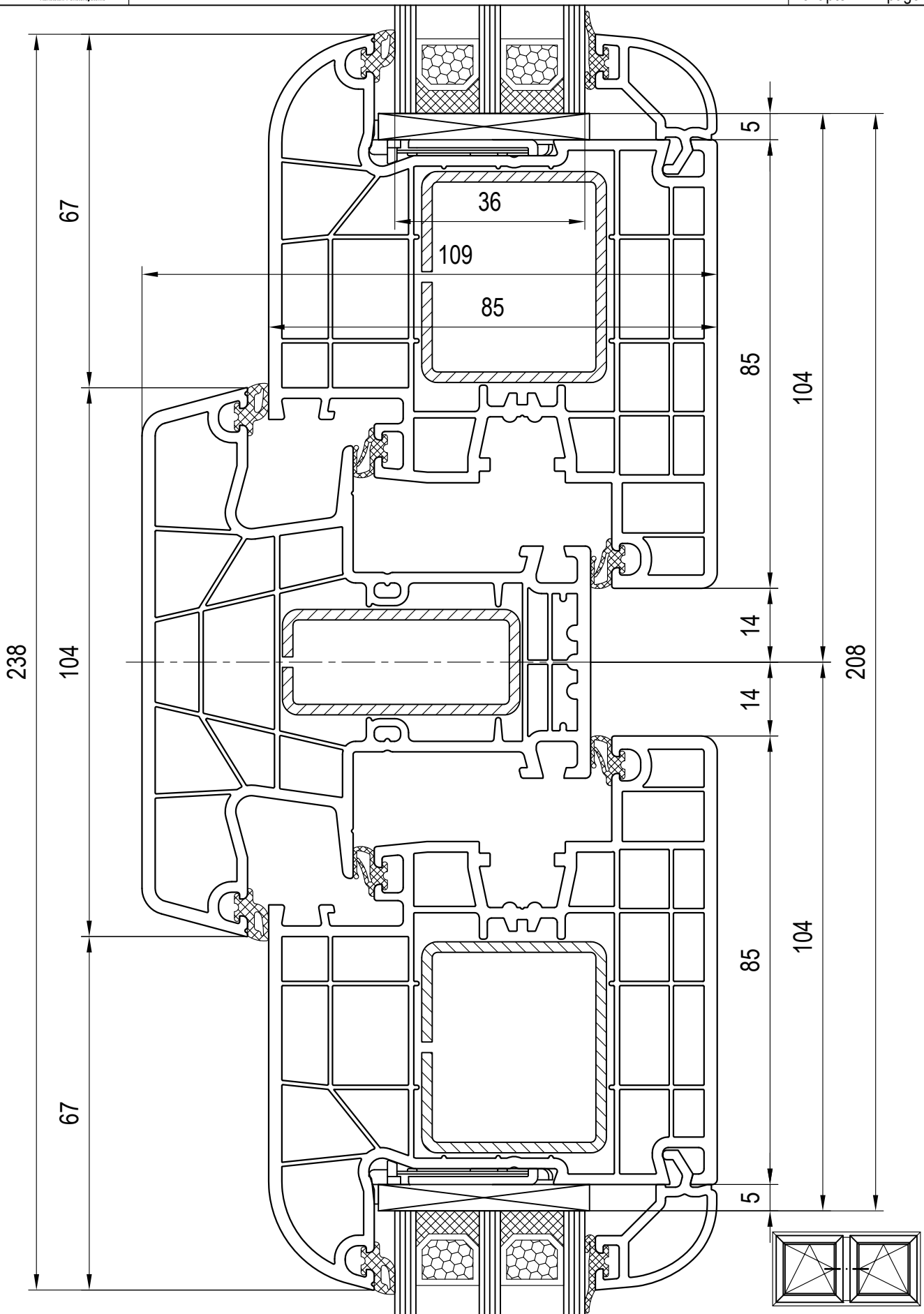

May be subject to change and errors excepted!

scale: 1:1  
03\_G\_01\_8\*

Combinations: Sash - Mullion - Sash  
Glazing Bead 120650/120680

Mullion 180x44  
Sash 180x32

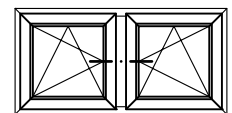
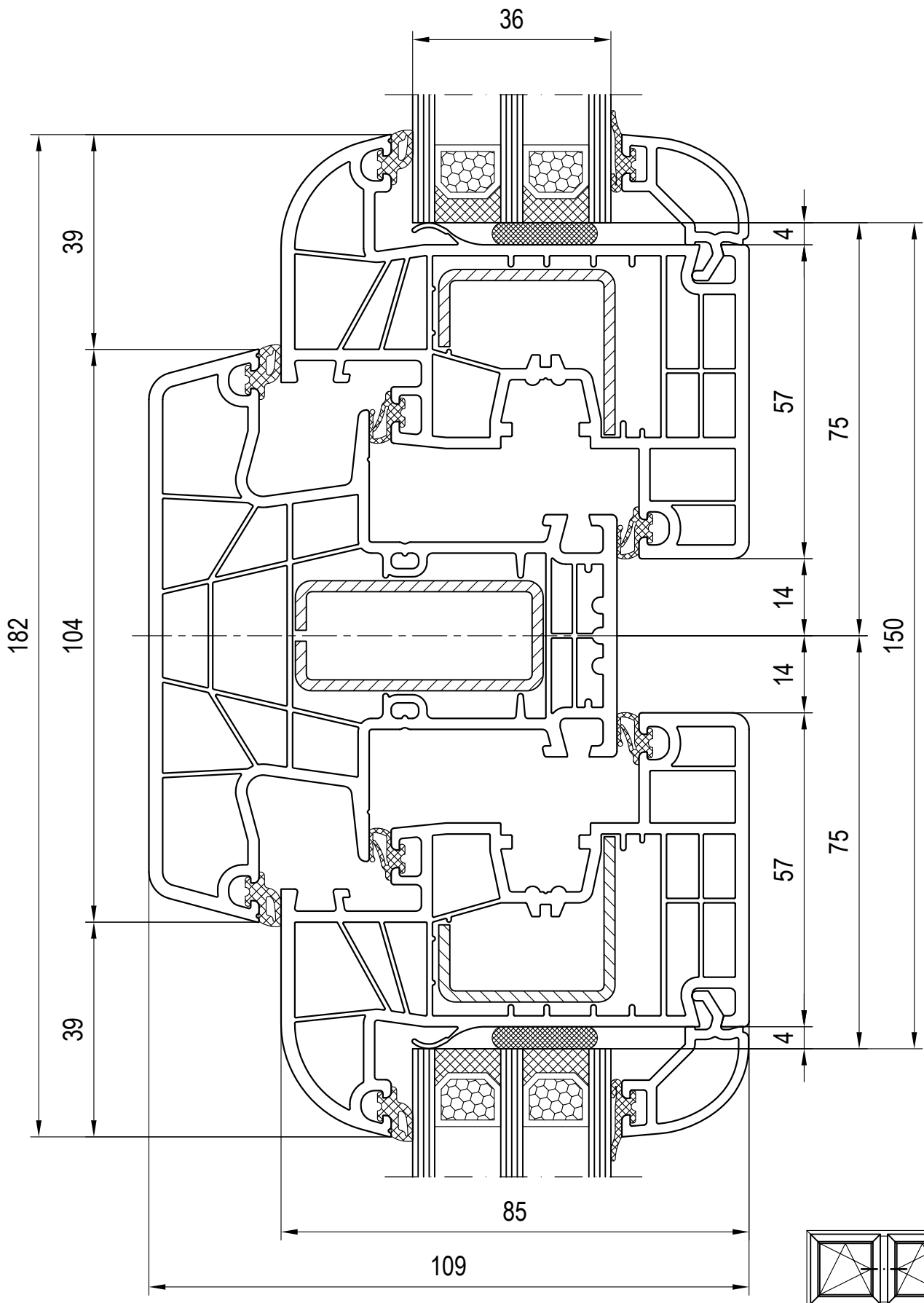

May be subject to change and errors excepted!

scale: 1:1  
03\_G\_01\_8\*

Combinations: Sash - Mullion - Sash  
Glazing Bead 120650/120680

Mullion 180x44  
Sash 180x83

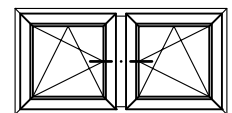
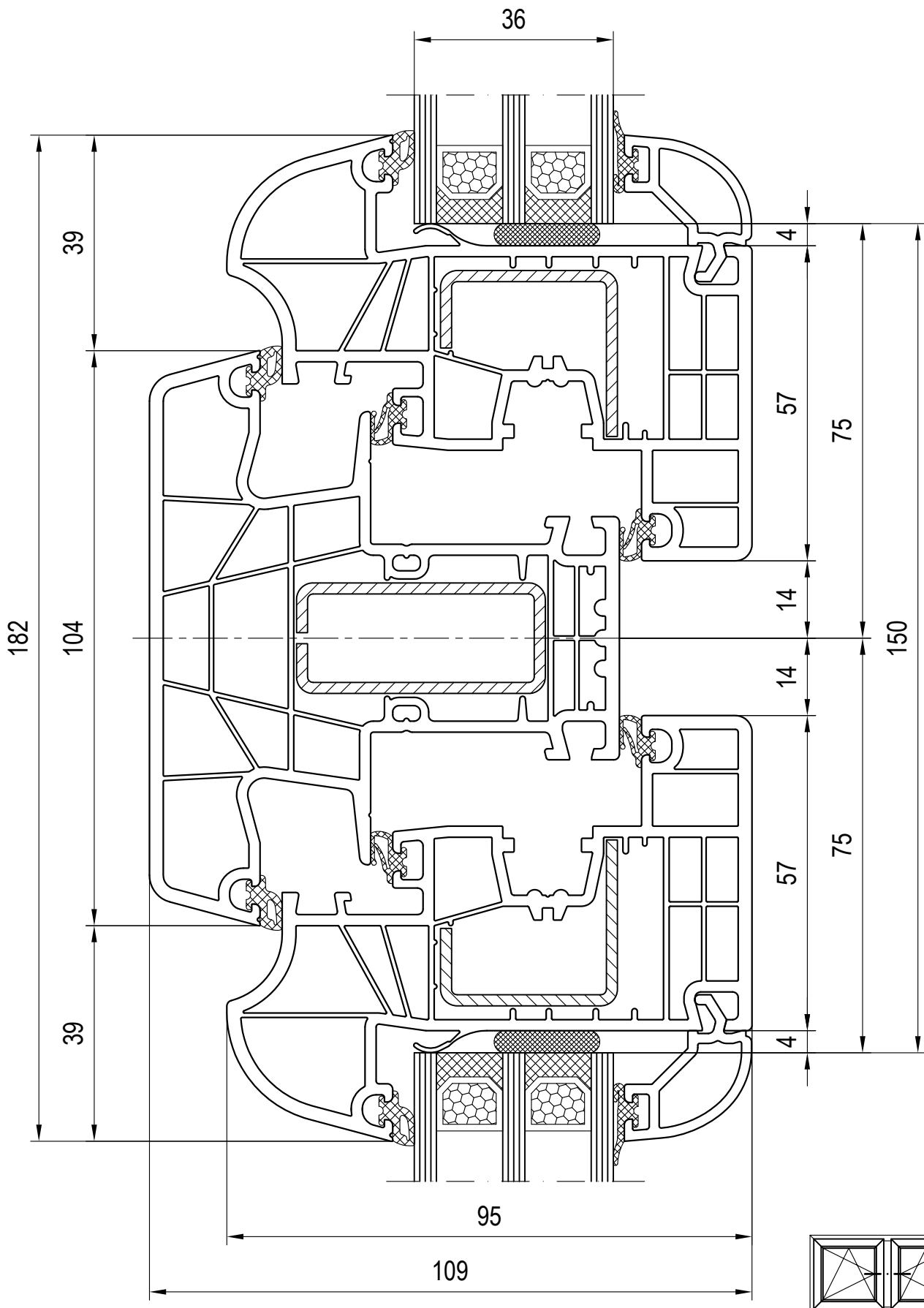

May be subject to change and errors excepted!

scale: 1:1  
03\_G\_01\_8\*

Combinations: Sash - Mullion - Sash  
Glazing Bead 120650/120680

Mullion 180x44  
Sash 180x85

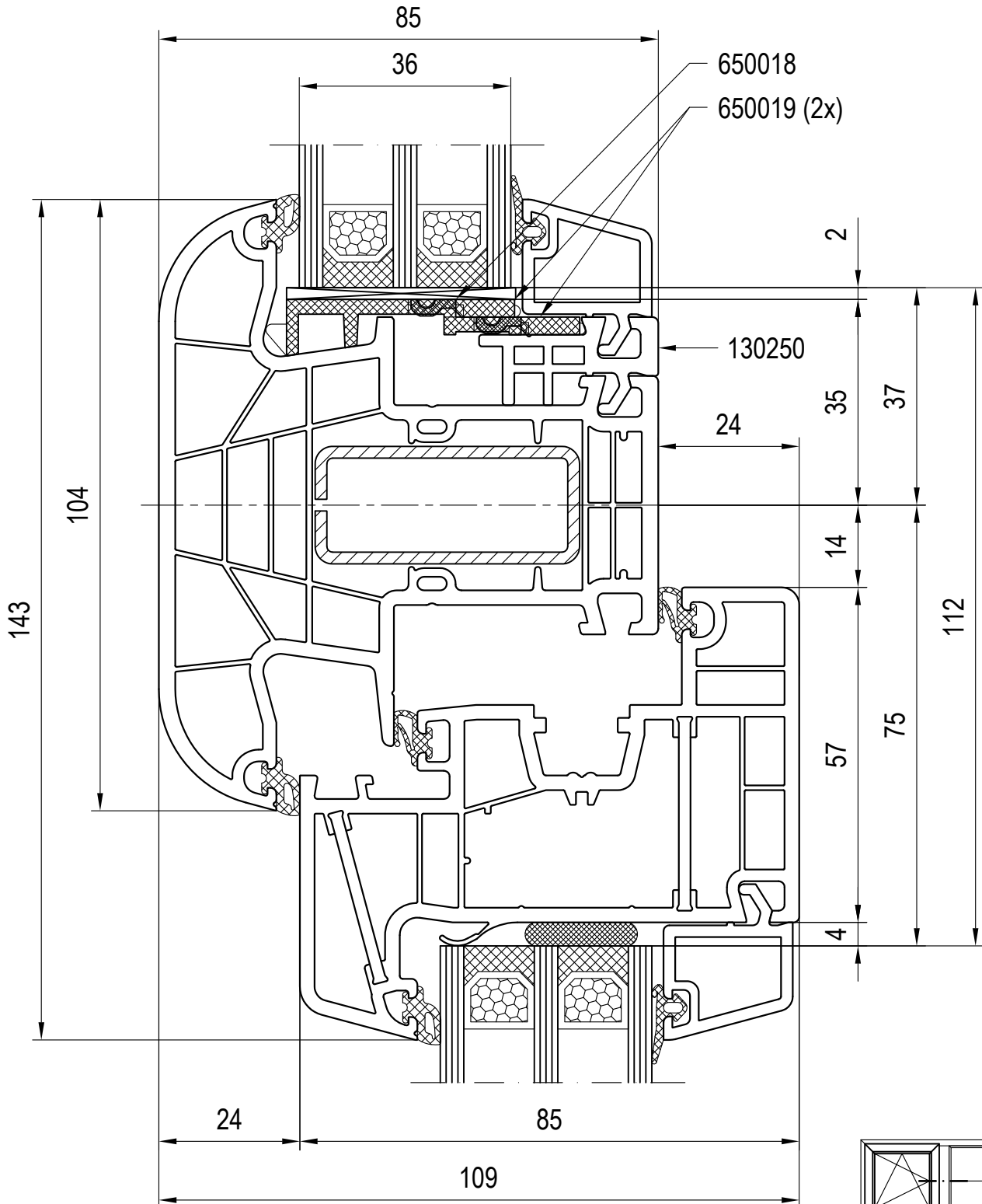

For alternative see chapter 03 A.

May be subject to change  
and errors excepted!

scale: 1:1  
03\_H\_01\_8\*

Combinations: Sash - Mullion - Fixed Glazing  
Glazing Bead 120636/120666

Mullion 180x43  
Sash 080x86



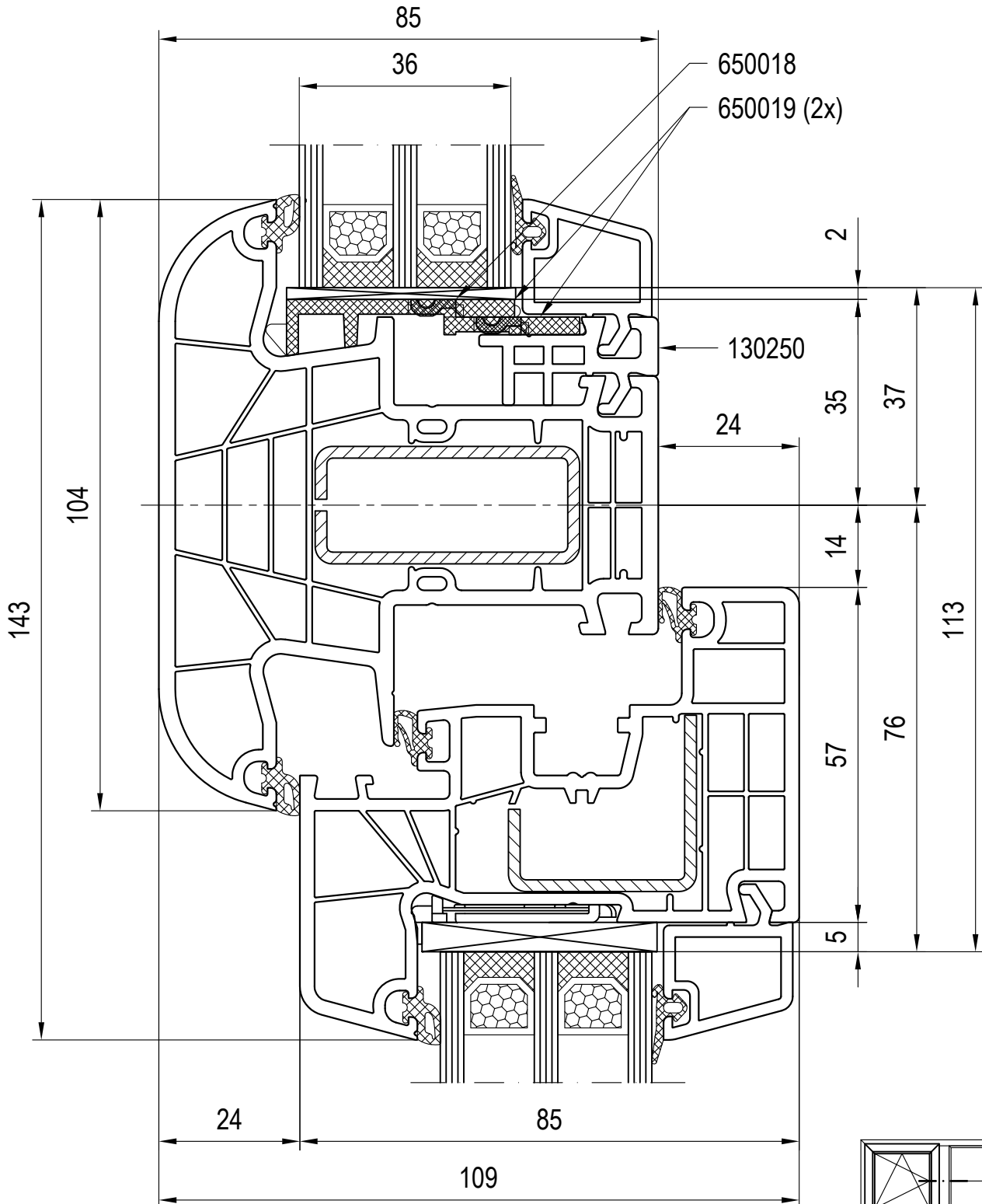

For alternative see chapter 03 A.

May be subject to change  
and errors excepted!

scale: 1:1  
03\_H\_01\_8\*

Combinations: Sash - Mullion - Fixed Glazing  
Glazing Bead 120636/120666

Mullion 180x43  
Sash 180x20

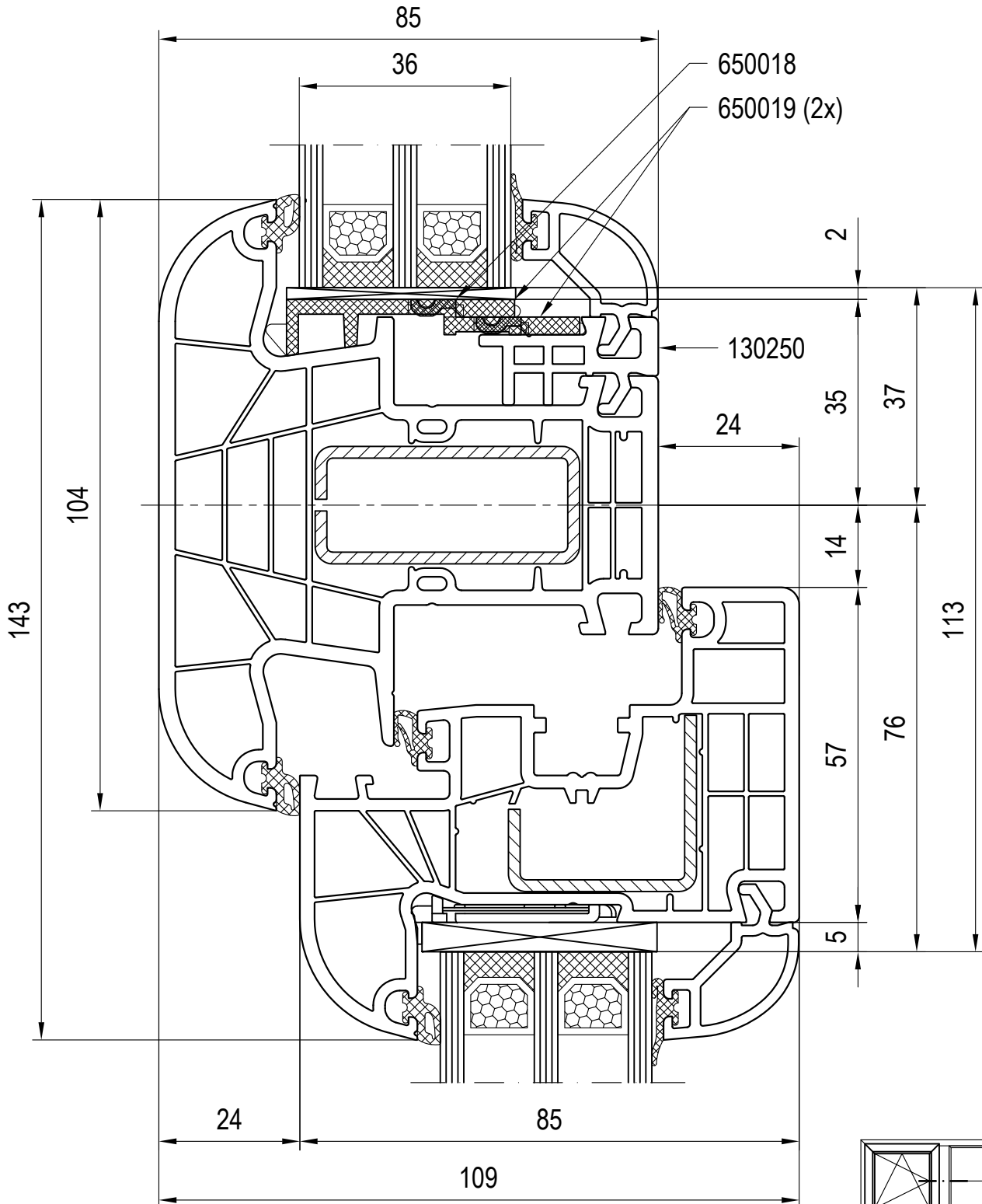

For alternative see chapter 03 A.

May be subject to change  
and errors excepted!

scale: 1:1  
03\_H\_01\_8\*

Combinations: Sash - Mullion - Fixed Glazing  
Glazing Bead 120650/120680

Mullion 180x43  
Sash 180x22

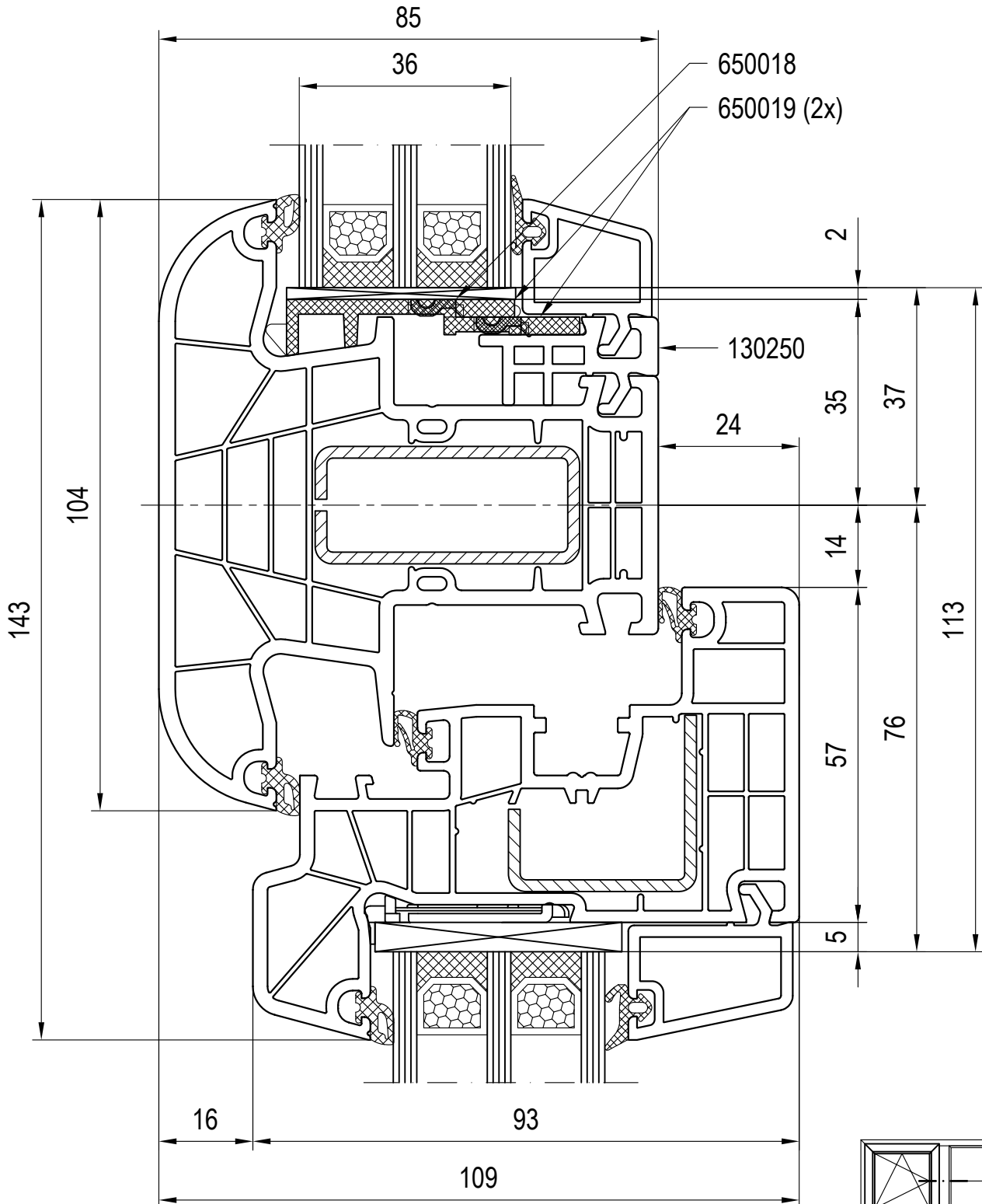

For alternative see chapter 03 A.

May be subject to change  
and errors excepted!

scale: 1:1  
03\_H\_01\_8\*

Combinations: Sash - Mullion - Fixed Glazing

Glazing Bead 120838/120868(120636/120666)

Mullion 180x43

Sash 180x26

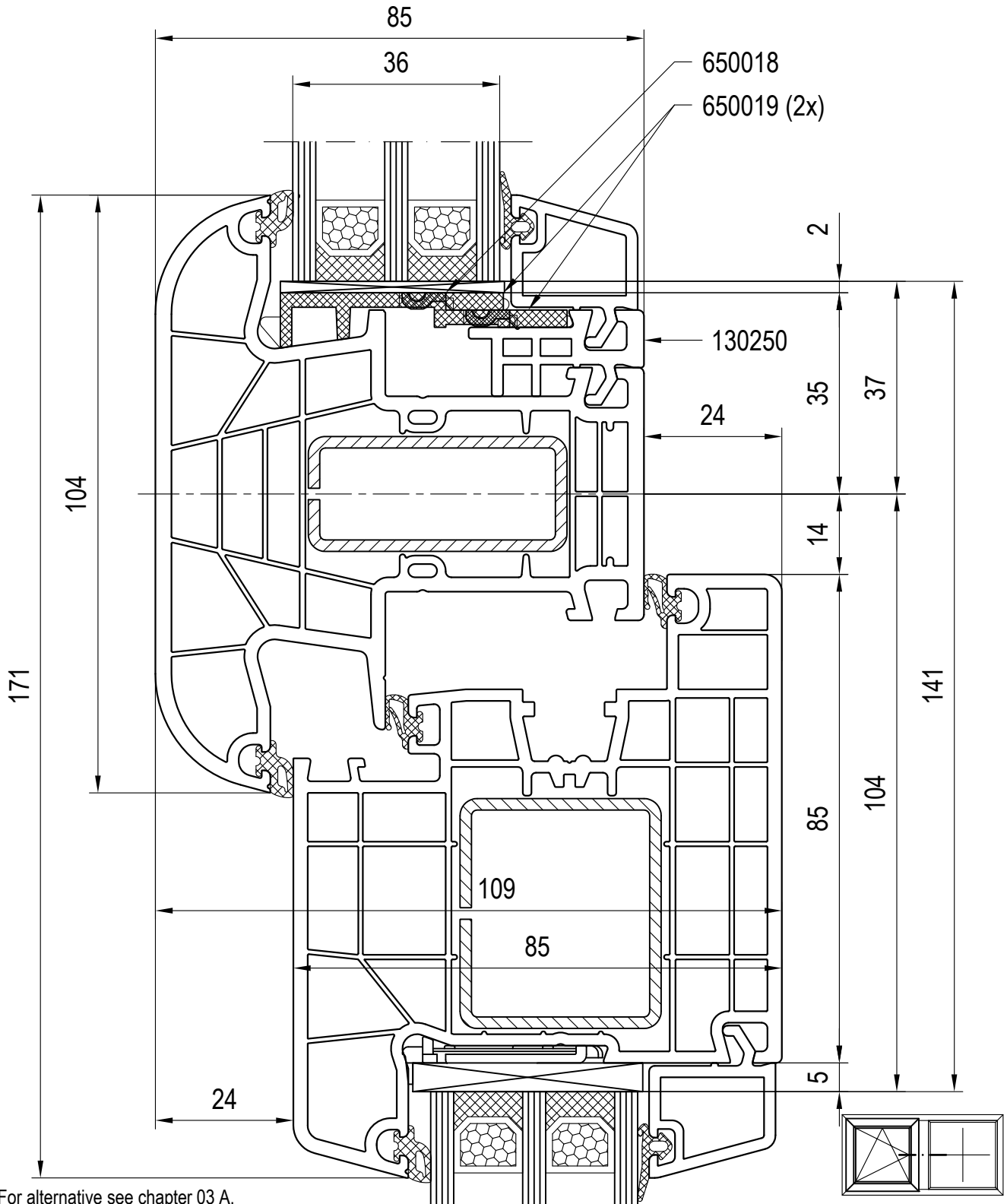

For alternative see chapter 03 A.

May be subject to change  
and errors excepted!

scale: 1:1  
03\_H\_01\_8\*

Combinations: Sash - Mullion - Fixed Glazing  
Glazing Bead 120636/120666

Mullion 180x43  
Sash 180x30

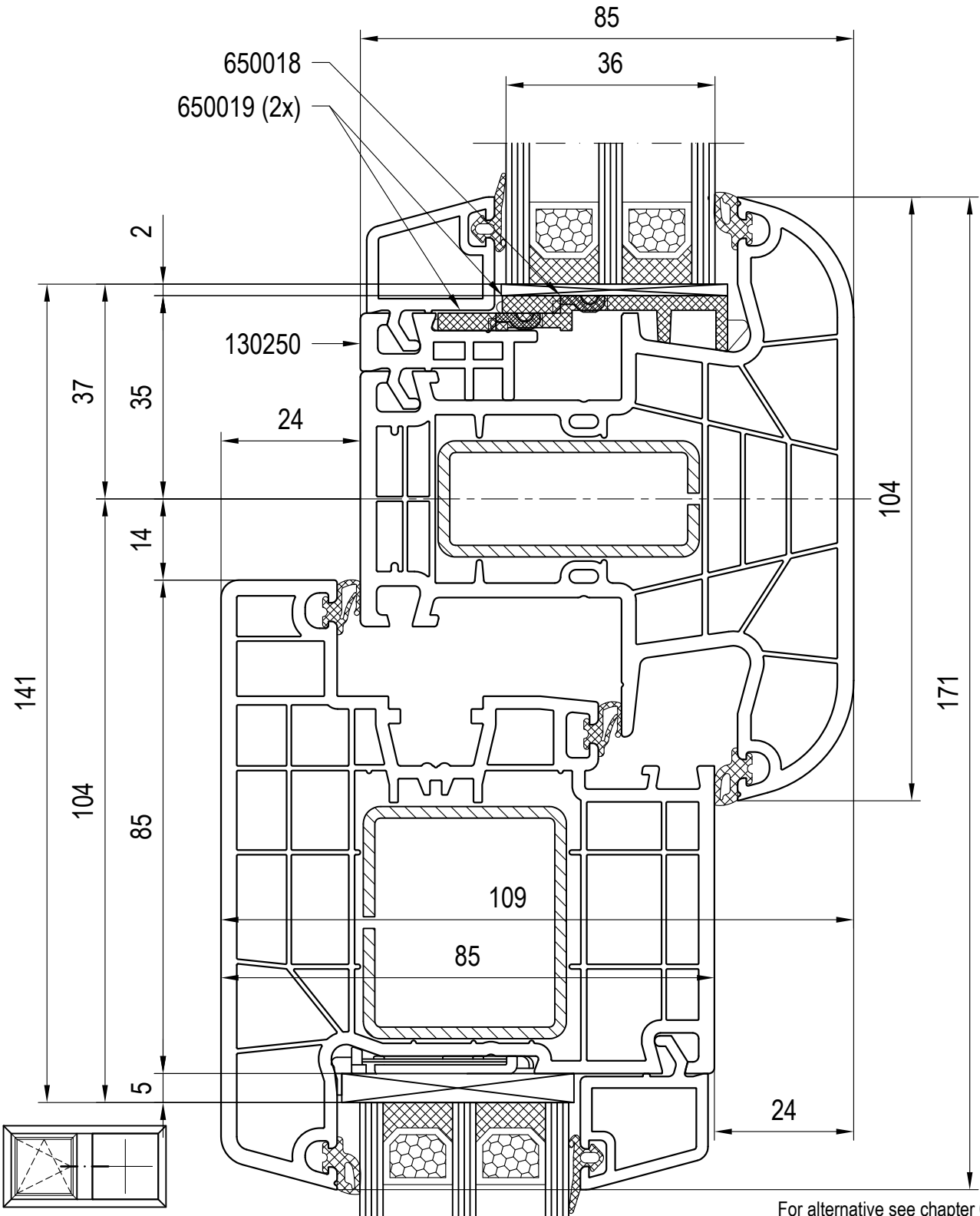

For alternative see chapter 03 A.

May be subject to change  
and errors excepted!

scale: 1:1  
03\_H\_01\_8\*

Combinations: Sash - Mullion - Fixed Glazing  
Glazing Bead 120636/120666

**Mullion 180x43**  
**Sash 180x31**

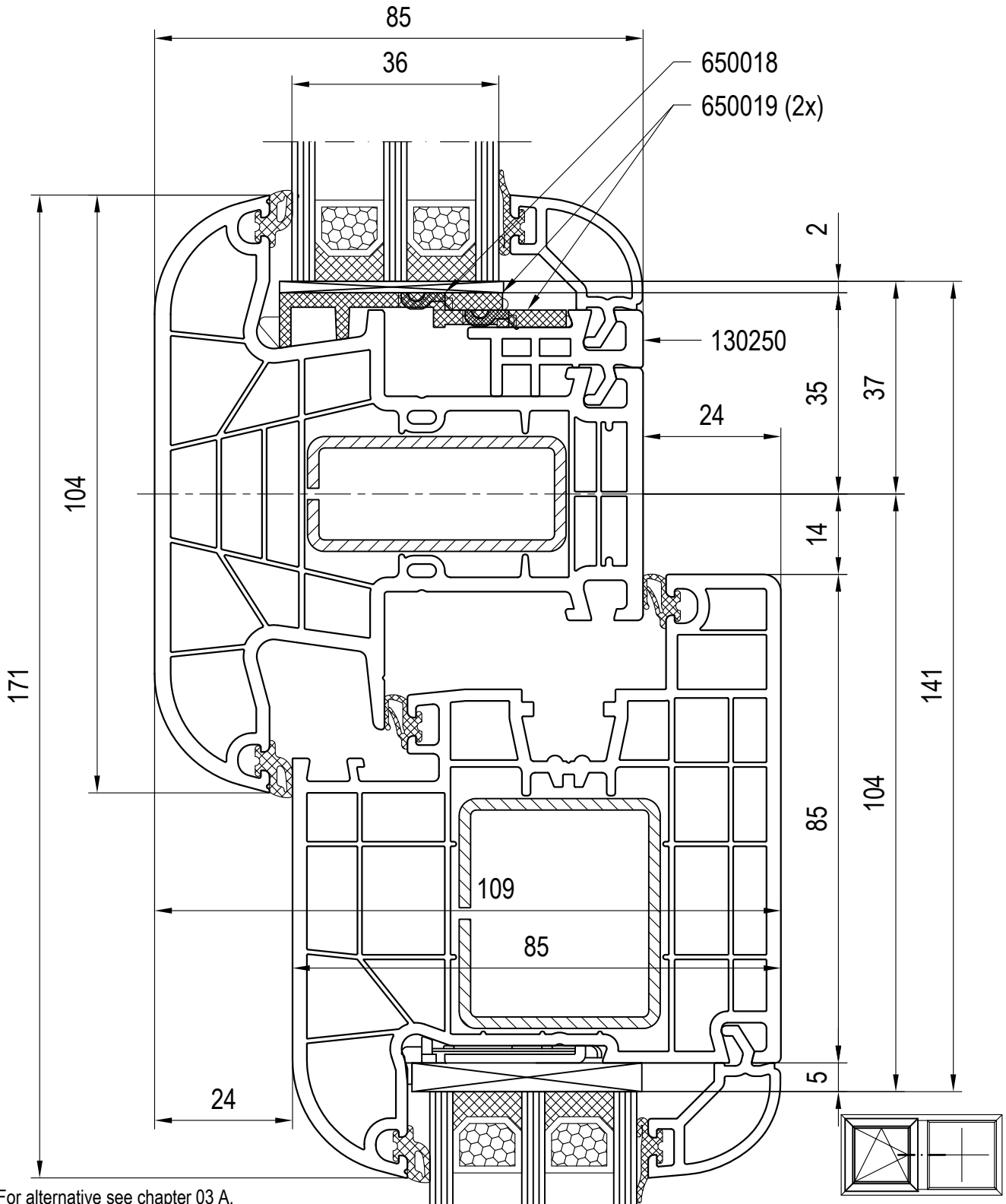

For alternative see chapter 03 A.

May be subject to change  
and errors excepted!

scale: 1:1  
03\_H\_01\_8\*

Combinations: Sash - Mullion - Fixed Glazing  
Glazing Bead 120650/120680

Mullion 180x43  
Sash 180x32

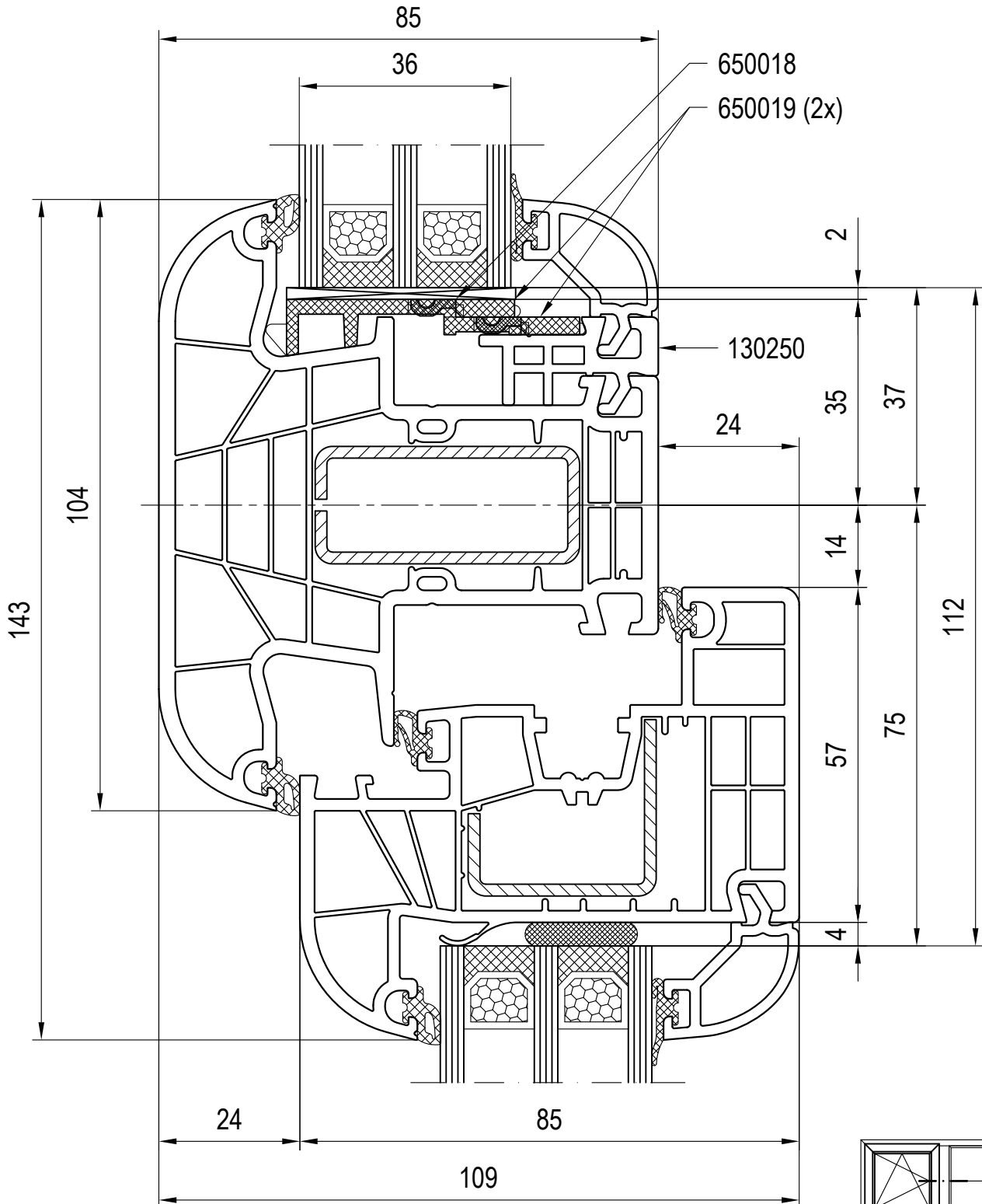

For alternative see chapter 03 A.

May be subject to change  
and errors excepted!

scale: 1:1  
03\_H\_01\_8\*

Combinations: Sash - Mullion - Fixed Glazing  
Glazing Bead 120650/120680

Mullion 180x43  
Sash 180x83

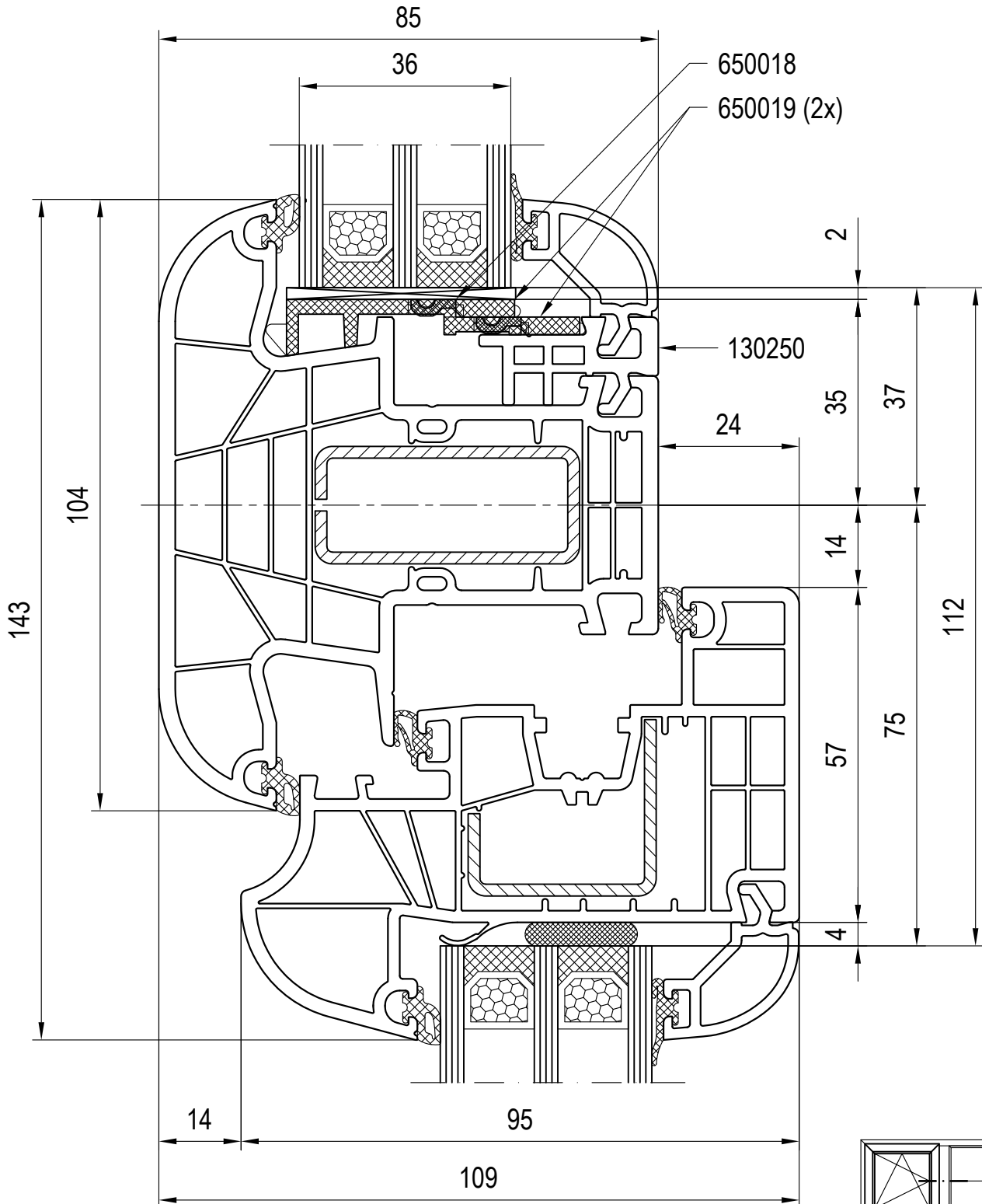

For alternative see chapter 03 A.

May be subject to change  
and errors excepted!

scale: 1:1  
03\_H\_01\_8\*

Combinations: Sash - Mullion - Fixed Glazing  
Glazing Bead 120650/120680

Mullion 180x43  
Sash 180x85



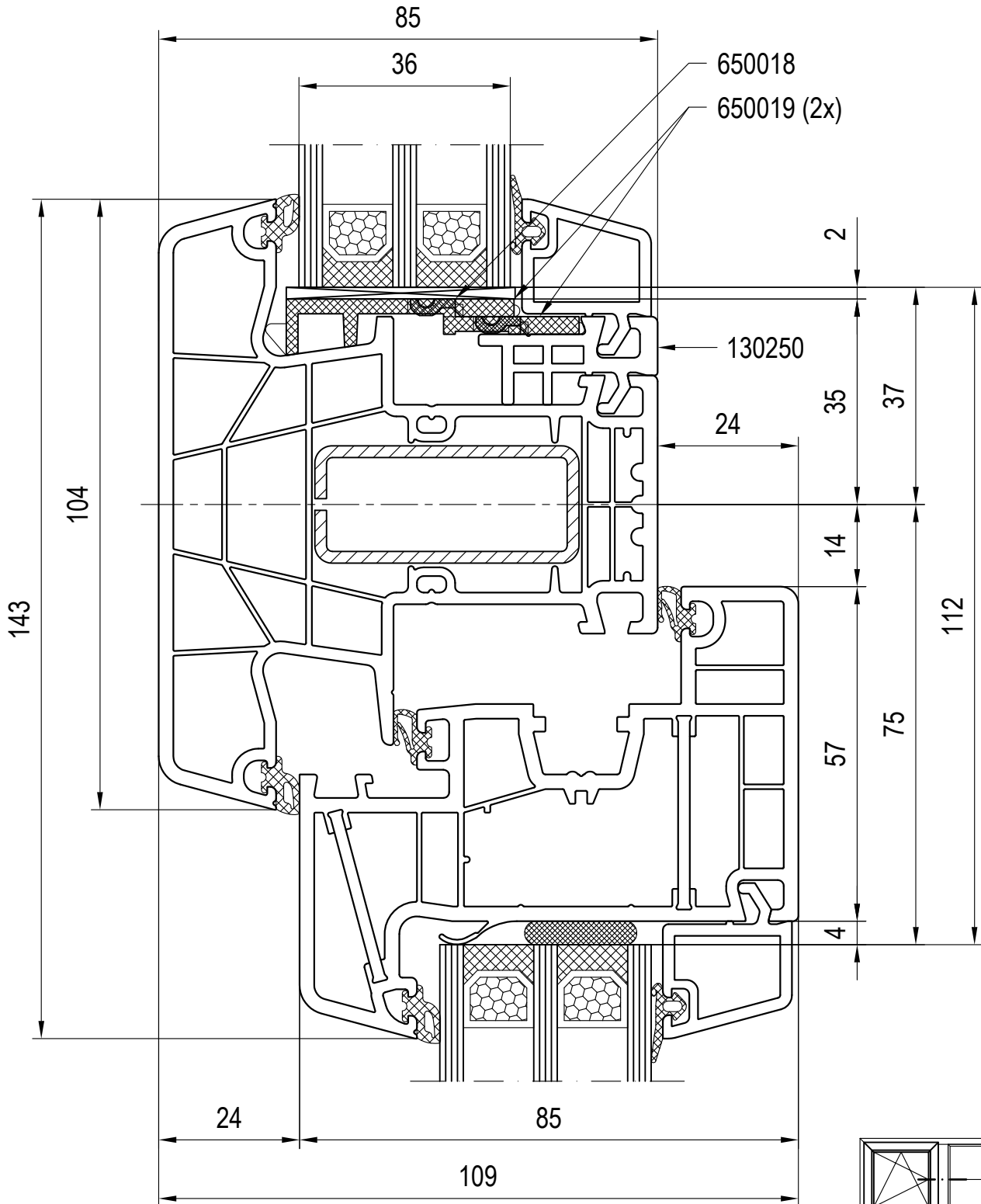

For alternative see chapter 03 A.

May be subject to change  
 and errors excepted!  
 scale: 1:1  
 03\_H\_01\_8\*

Combinations: Sash - Mullion - Fixed Glazing  
 Glazing Bead 120636/120666

Mullion 180x44  
 Sash 080x86

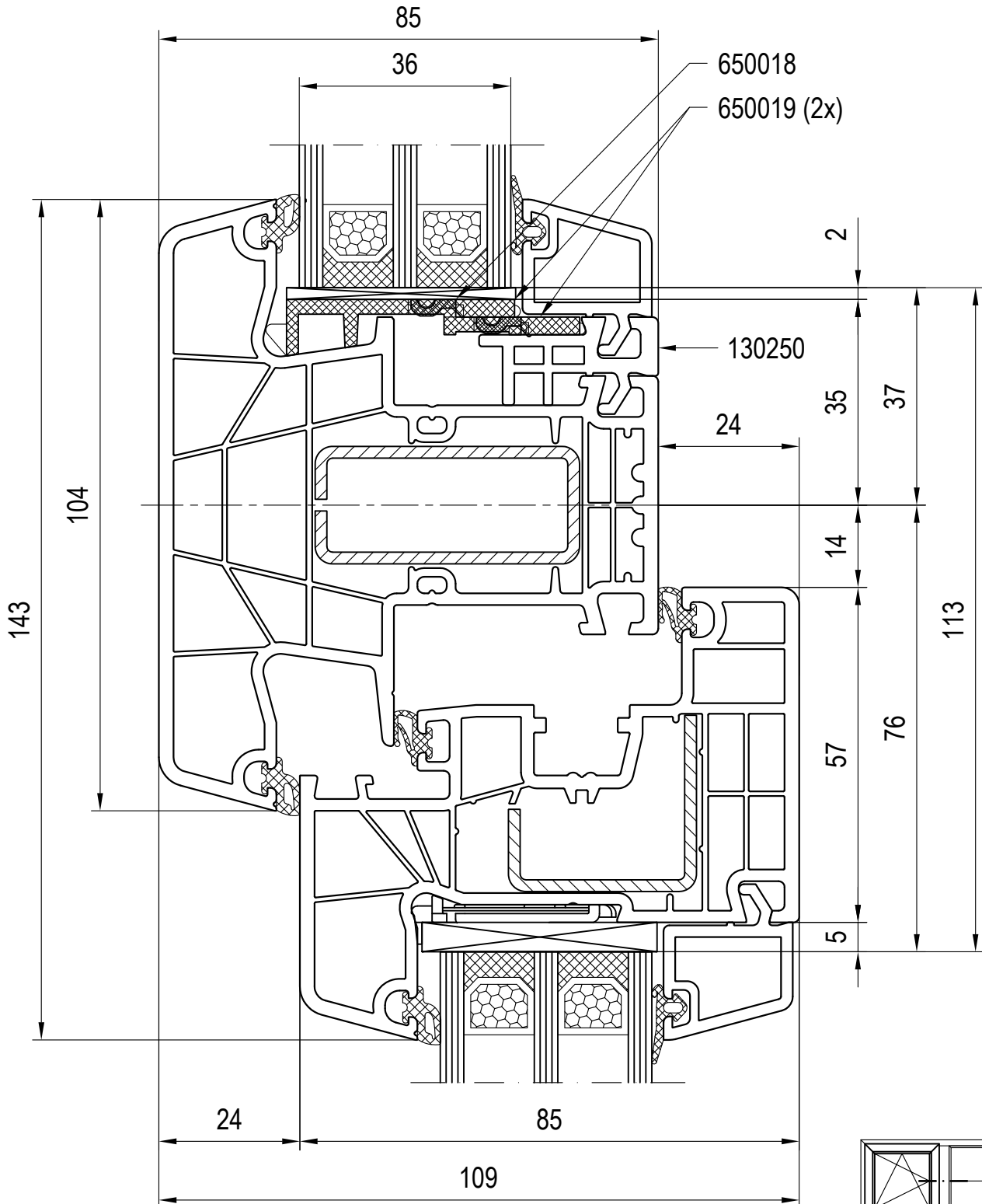

For alternative see chapter 03 A.

May be subject to change  
and errors excepted!

scale: 1:1  
03\_H\_01\_8\*

Combinations: Sash - Mullion - Fixed Glazing  
Glazing Bead 120636/120666

Mullion 180x44  
Sash 180x20

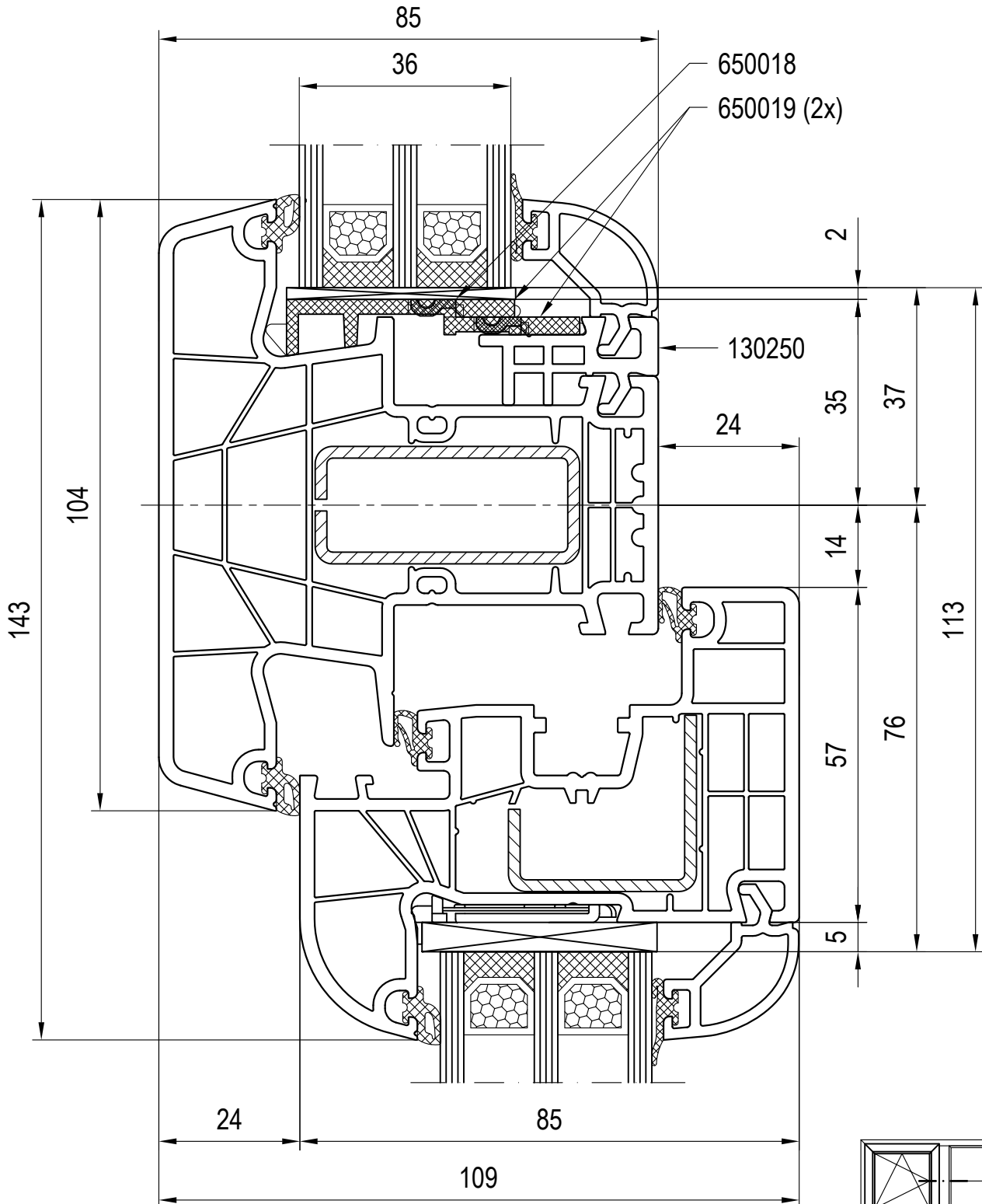

For alternative see chapter 03 A.

May be subject to change  
and errors excepted!

scale: 1:1  
03\_H\_01\_8\*

Combinations: Sash - Mullion - Fixed Glazing  
Glazing Bead 120650/120680

Mullion 180x44  
Sash 180x22

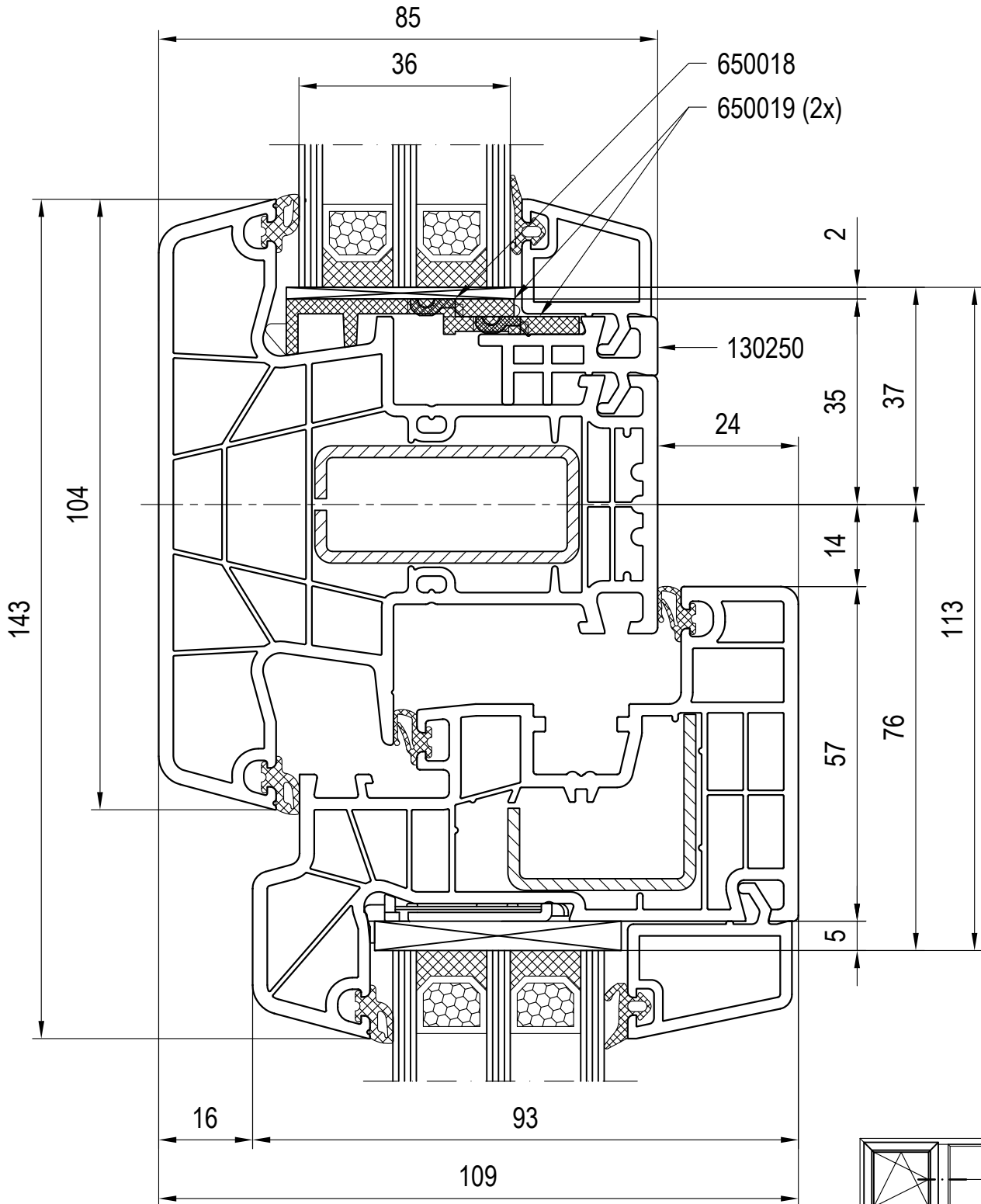

For alternative see chapter 03 A.

May be subject to change  
and errors excepted!

scale: 1:1  
03\_H\_01\_8\*

Combinations: Sash - Mullion - Fixed Glazing

Glazing Bead 120838/120868(120636/120666)

Mullion 180x44

Sash 180x26

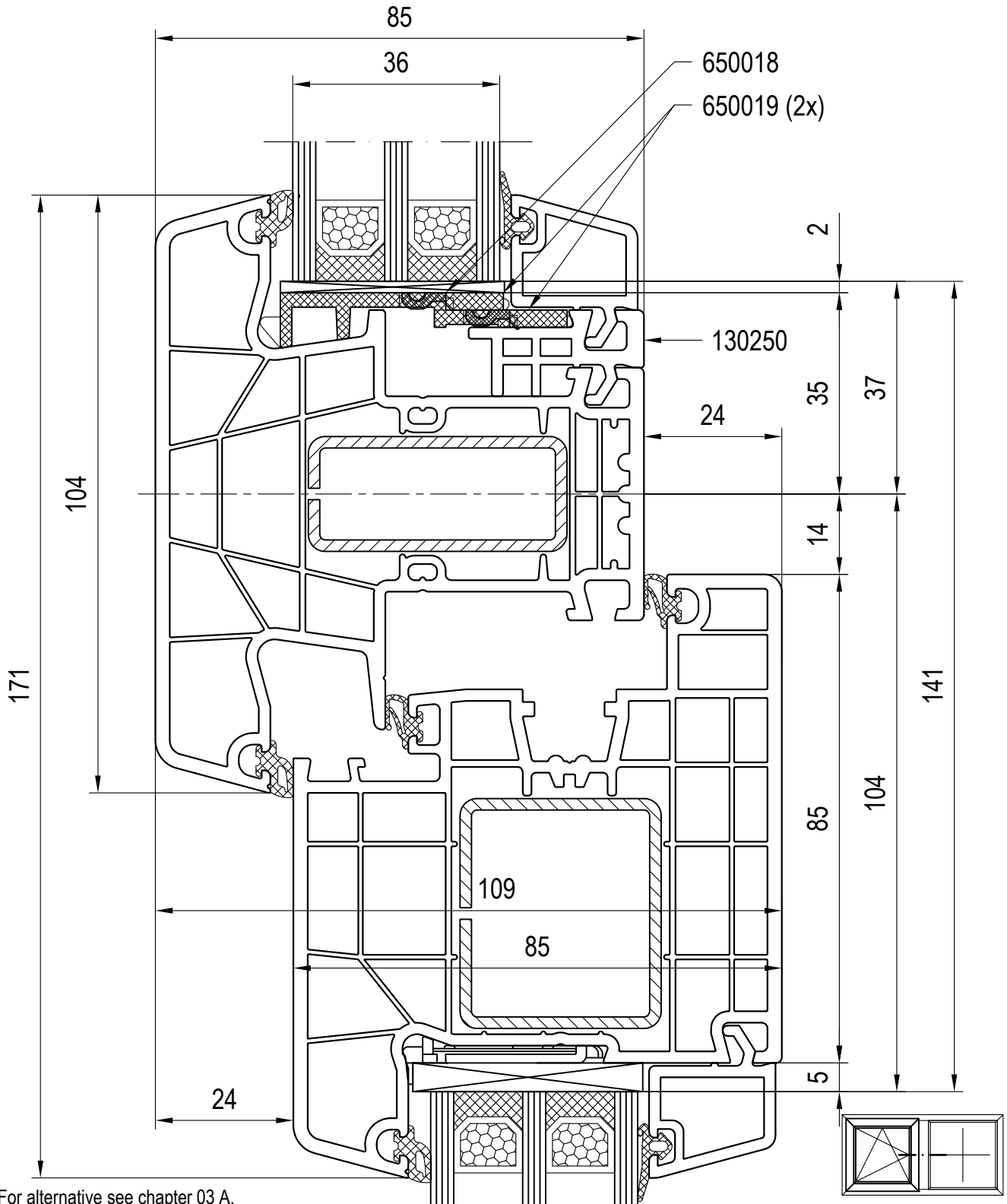

For alternative see chapter 03 A.

May be subject to change  
and errors excepted!

scale: 1:1  
03\_H\_01\_8\*

Combinations: Sash - Mullion - Fixed Glazing  
Glazing Bead 120636/120666

Mullion 180x44  
Sash 180x30

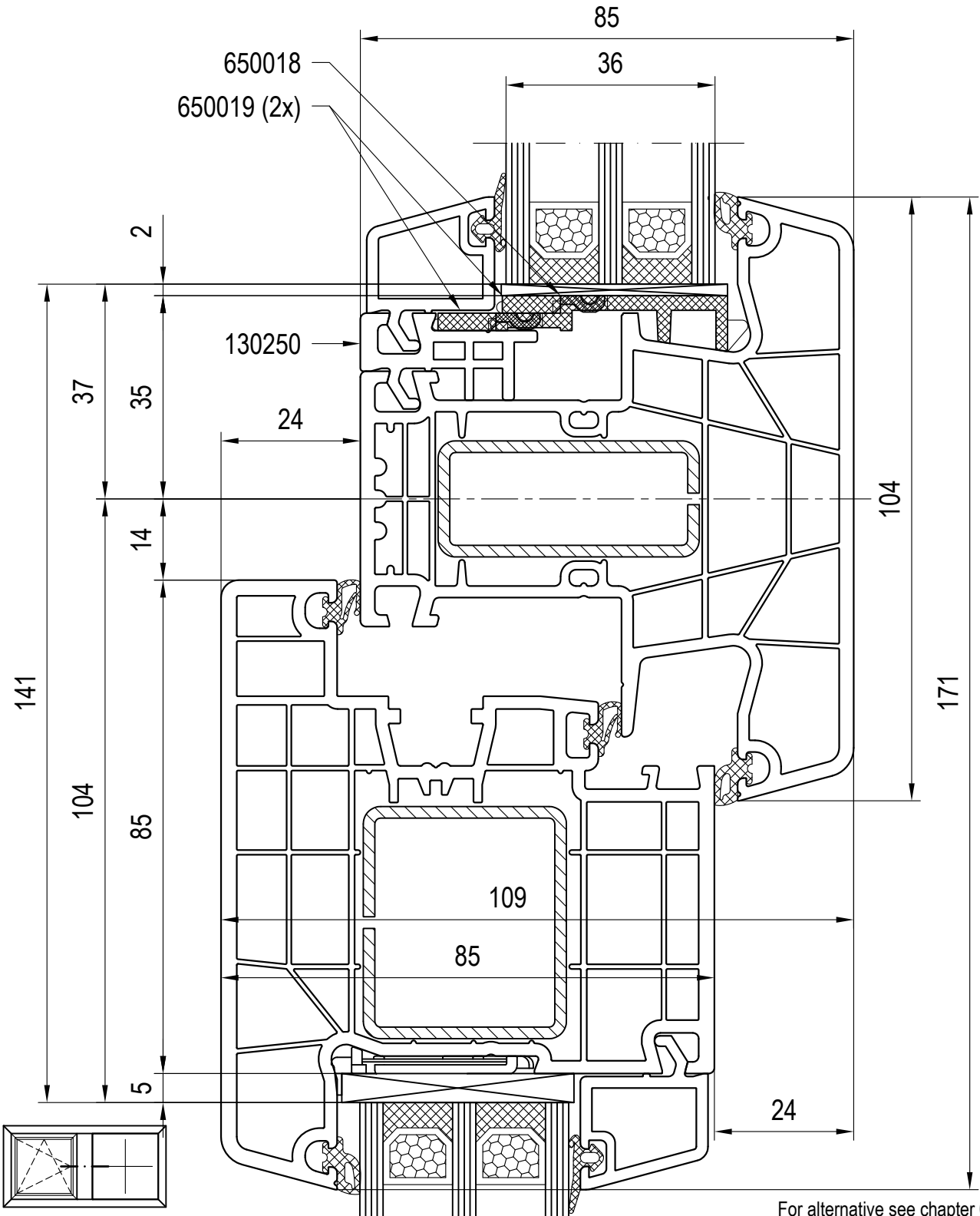

For alternative see chapter 03 A.

May be subject to change  
and errors excepted!

scale: 1:1  
03\_H\_01\_8\*

Combinations: Sash - Mullion - Fixed Glazing  
Glazing Bead 120636/120666

**Mullion 180x44**  
**Sash 180x31**

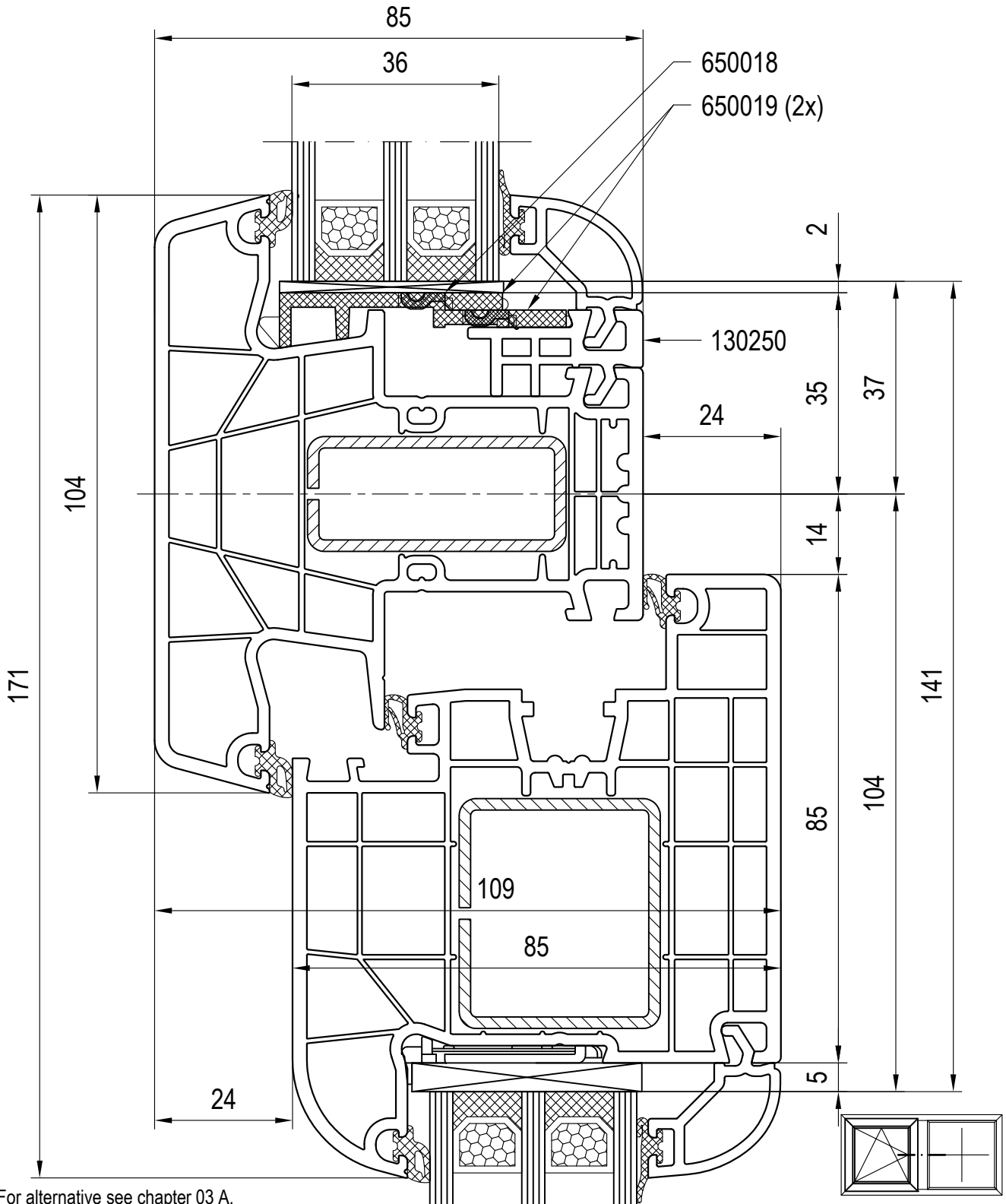

For alternative see chapter 03 A.

May be subject to change  
and errors excepted!

scale: 1:1  
03\_H\_01\_8\*

Combinations: Sash - Mullion - Fixed Glazing  
Glazing Bead 120650/120680

Mullion 180x44  
Sash 180x32

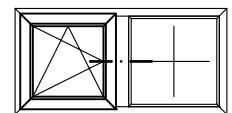
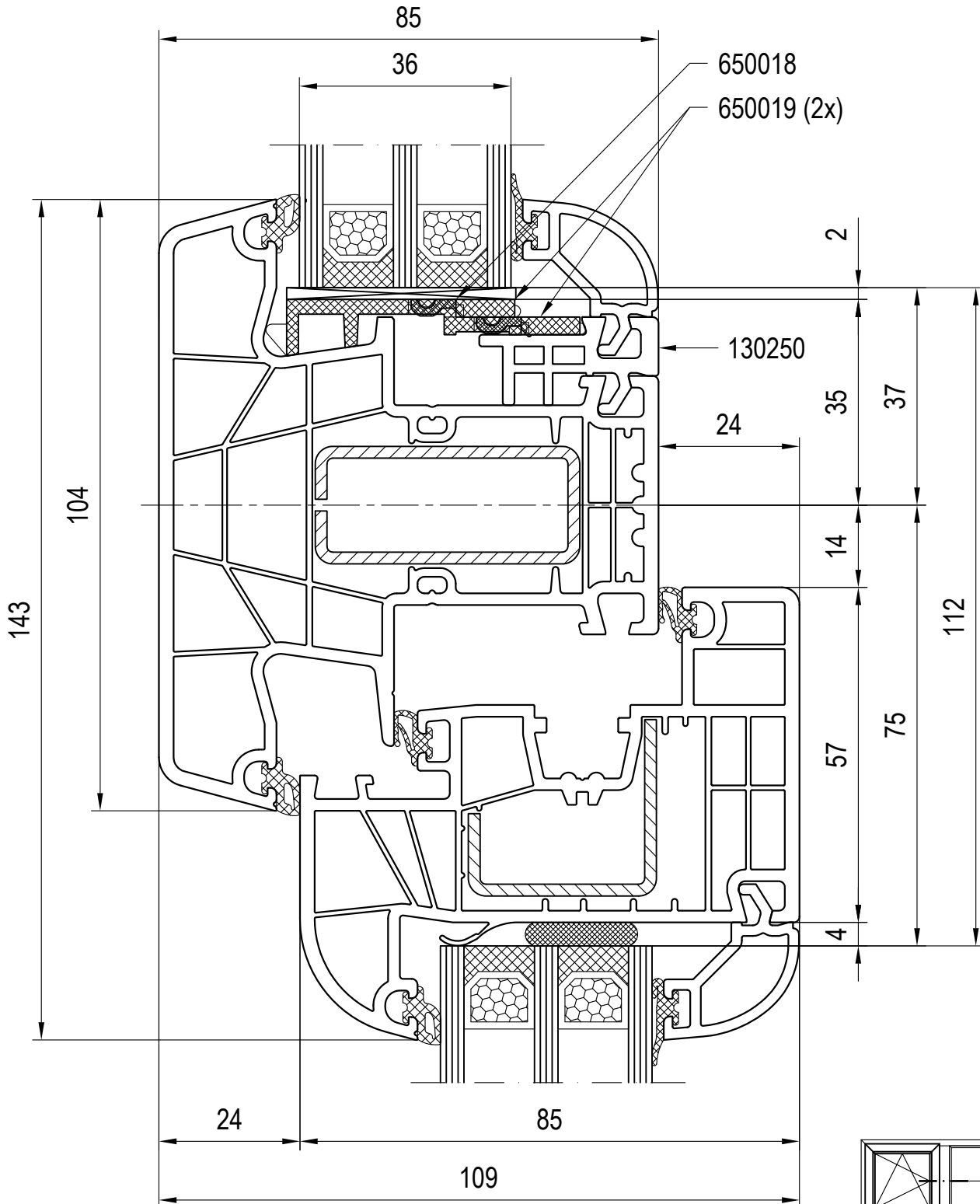

For alternative see chapter 03 A.

May be subject to change and errors excepted!

scale: 1:1  
03\_H\_01\_8\*

Combinations: Sash - Mullion - Fixed Glazing  
Glazing Bead 120650/120680

Mullion 180x44  
Sash 180x83



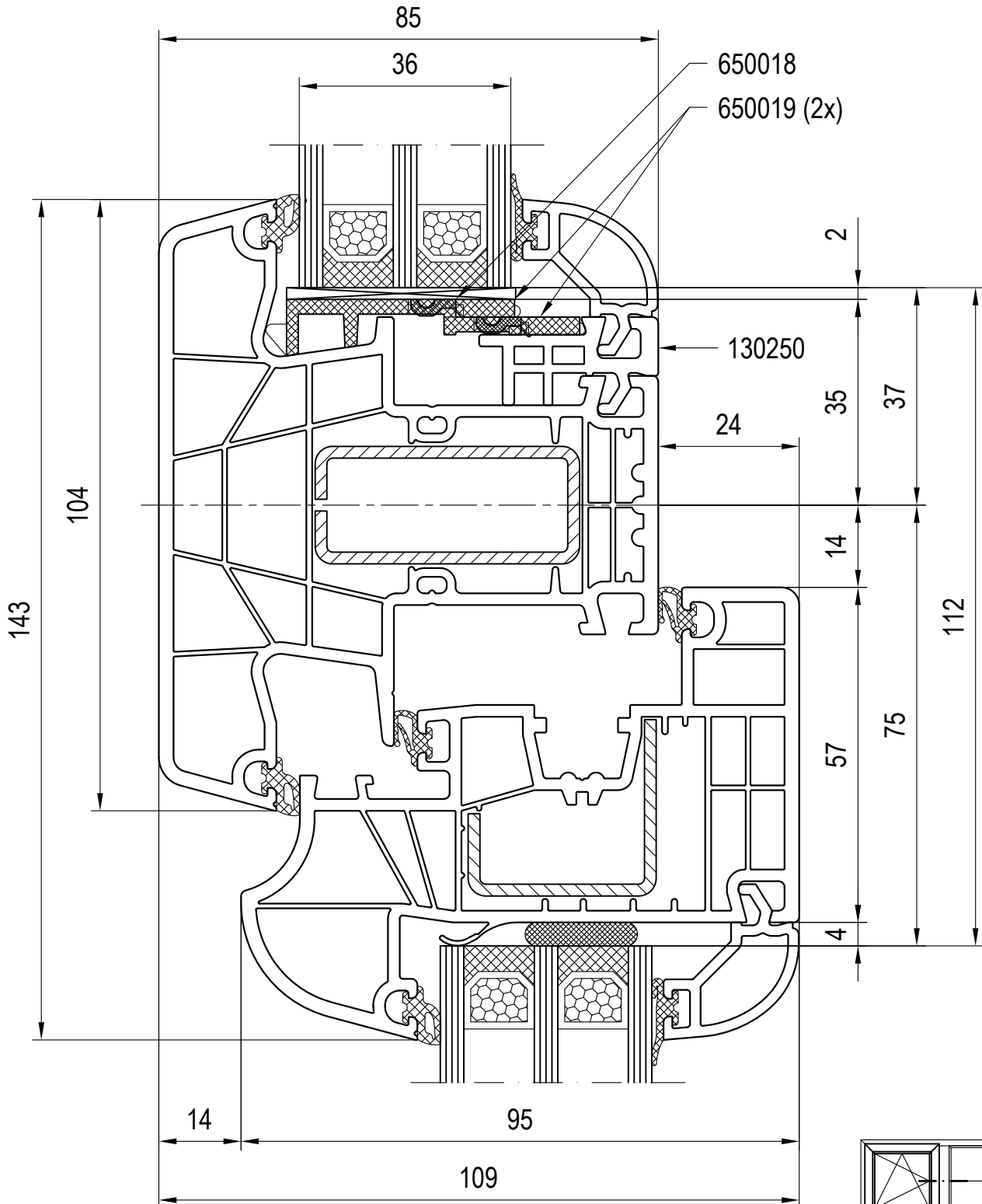

For alternative see chapter 03 A.

May be subject to change  
and errors excepted!

scale: 1:1  
03\_H\_01\_8\*

Combinations: Sash - Mullion - Fixed Glazing  
Glazing Bead 120650/120680

Mullion 180x44  
Sash 180x85

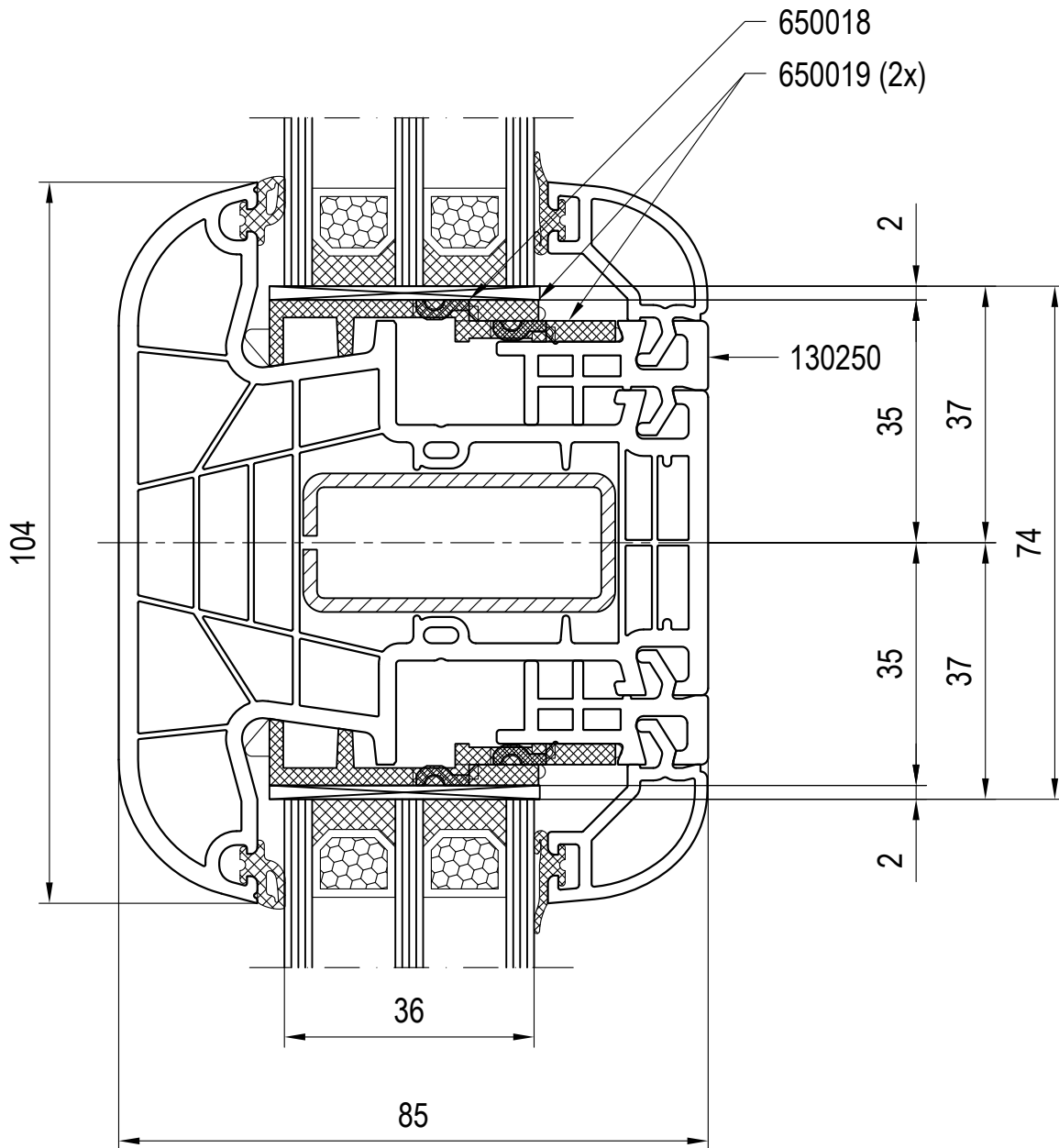

mullion

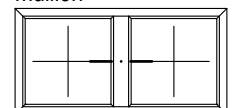

For alternatives see chapter 03 A.

May be subject to change  
and errors excepted!

scale: 1:1  
03\_J\_01\_8\*

Combinations: Mullion, Glazing-Divisive  
Glazing Bead 120650/120680

**Mullion 180x43**

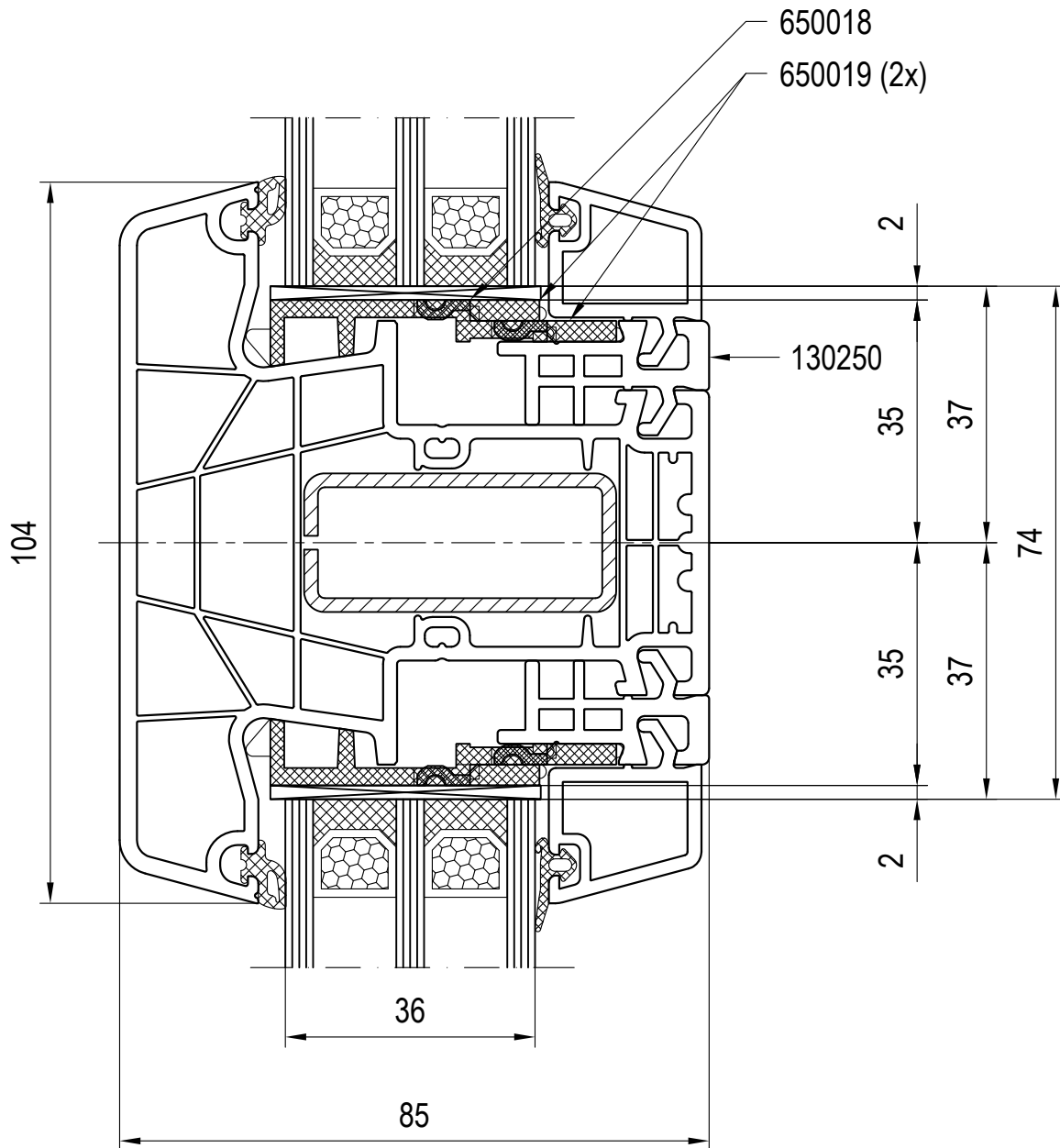

mullion

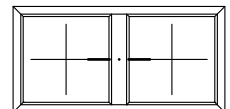

For alternatives see chapter 03 A.

May be subject to change  
and errors excepted!

scale: 1:1  
03\_J\_01\_8\*

Combinations: Mullion, Glazing-Divisive  
Glazing Bead 120636/120666

**Mullion 180x44**

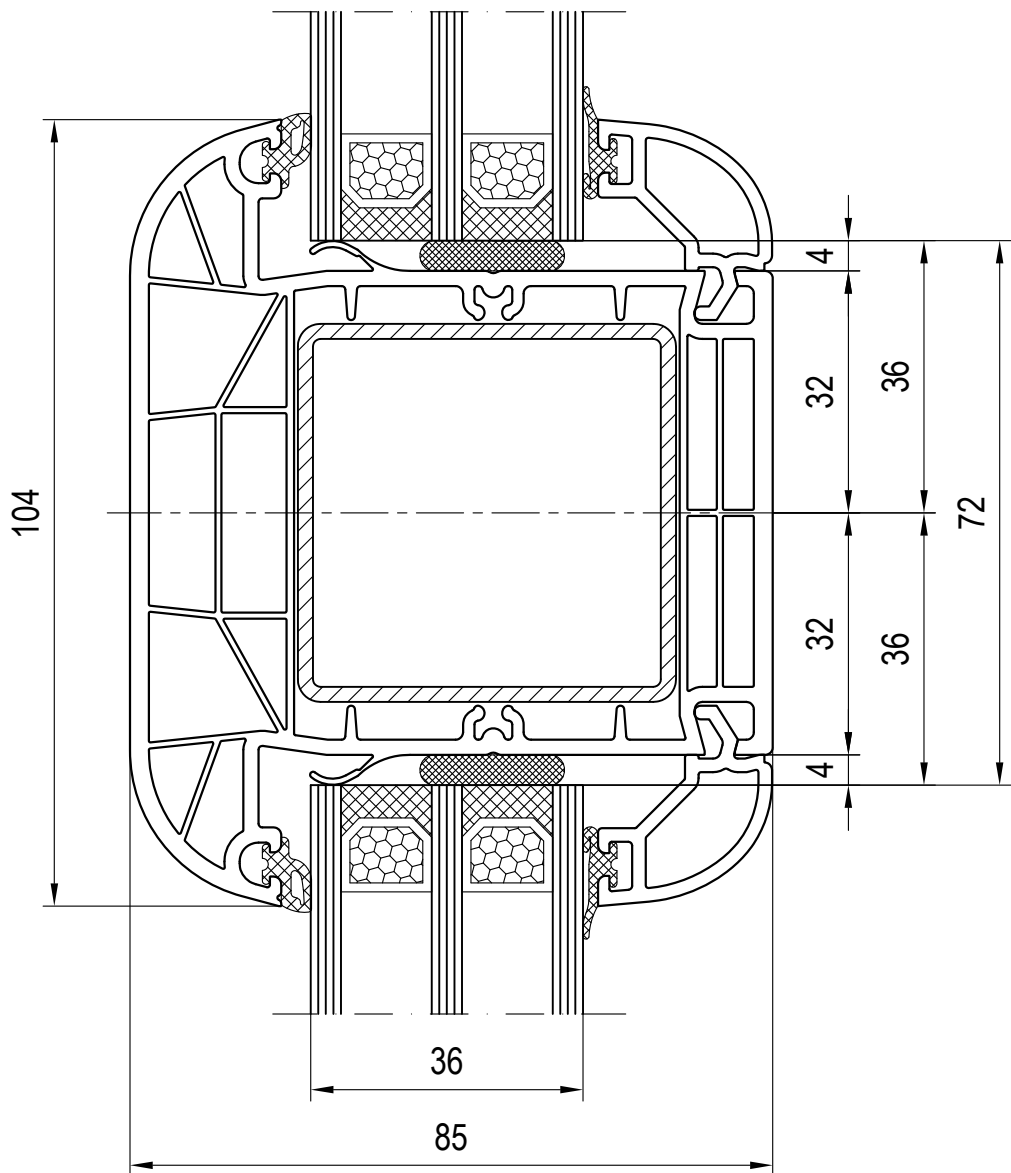

transom

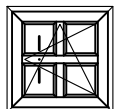

May be subject to change  
and errors excepted!

scale: 1:1  
03\_K\_01\_8\*

Combinations: Transom, Glazing-Divisive  
Glazing Bead 120650/120680

Transom 180x45

-

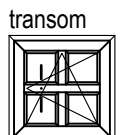
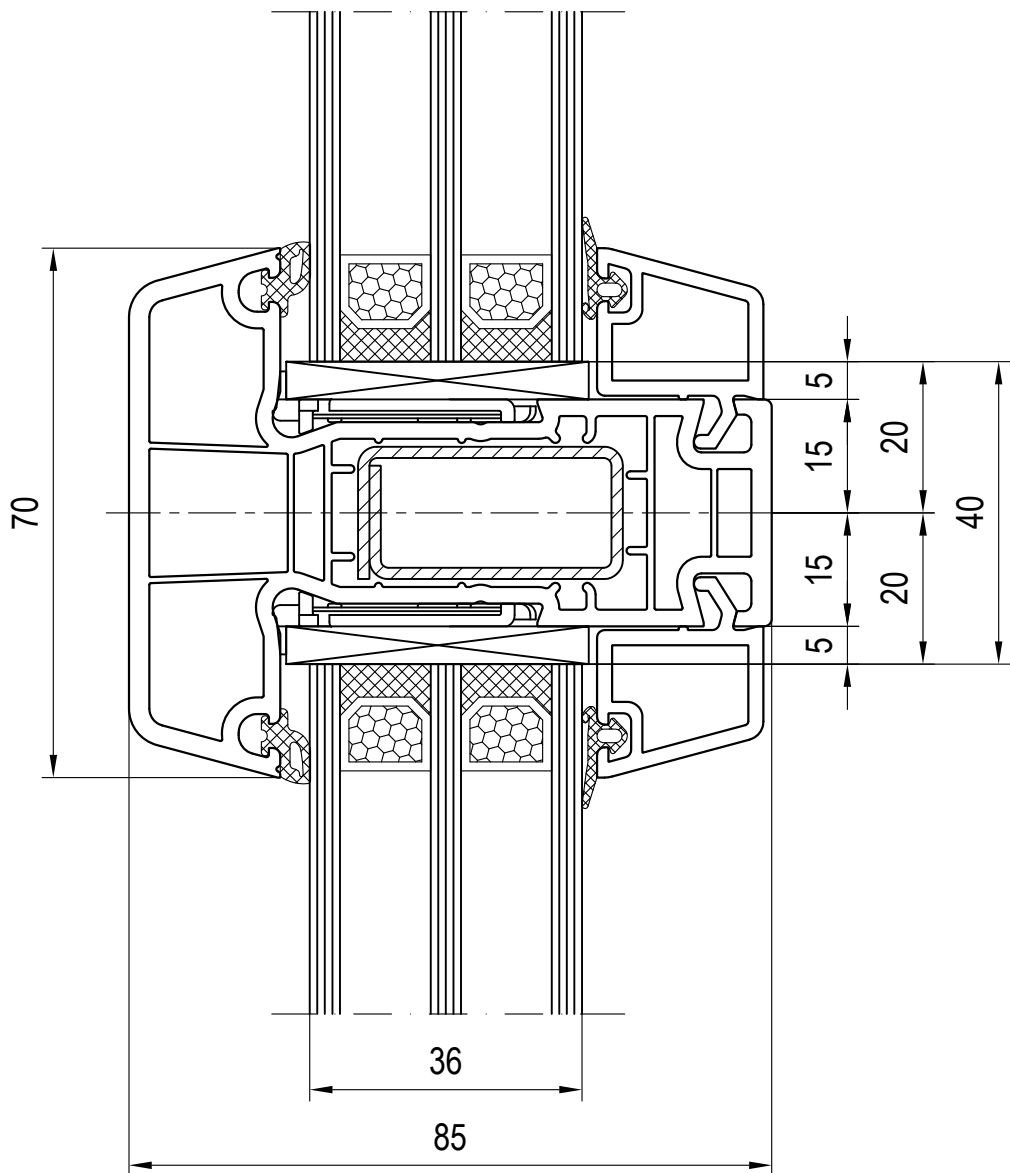

May be subject to change  
and errors excepted!

scale: 1:1  
03\_K\_01\_8\*

Combinations: Transom, Glazing-Divisive  
Glazing Bead 120636/120666

Transom 180x46

-

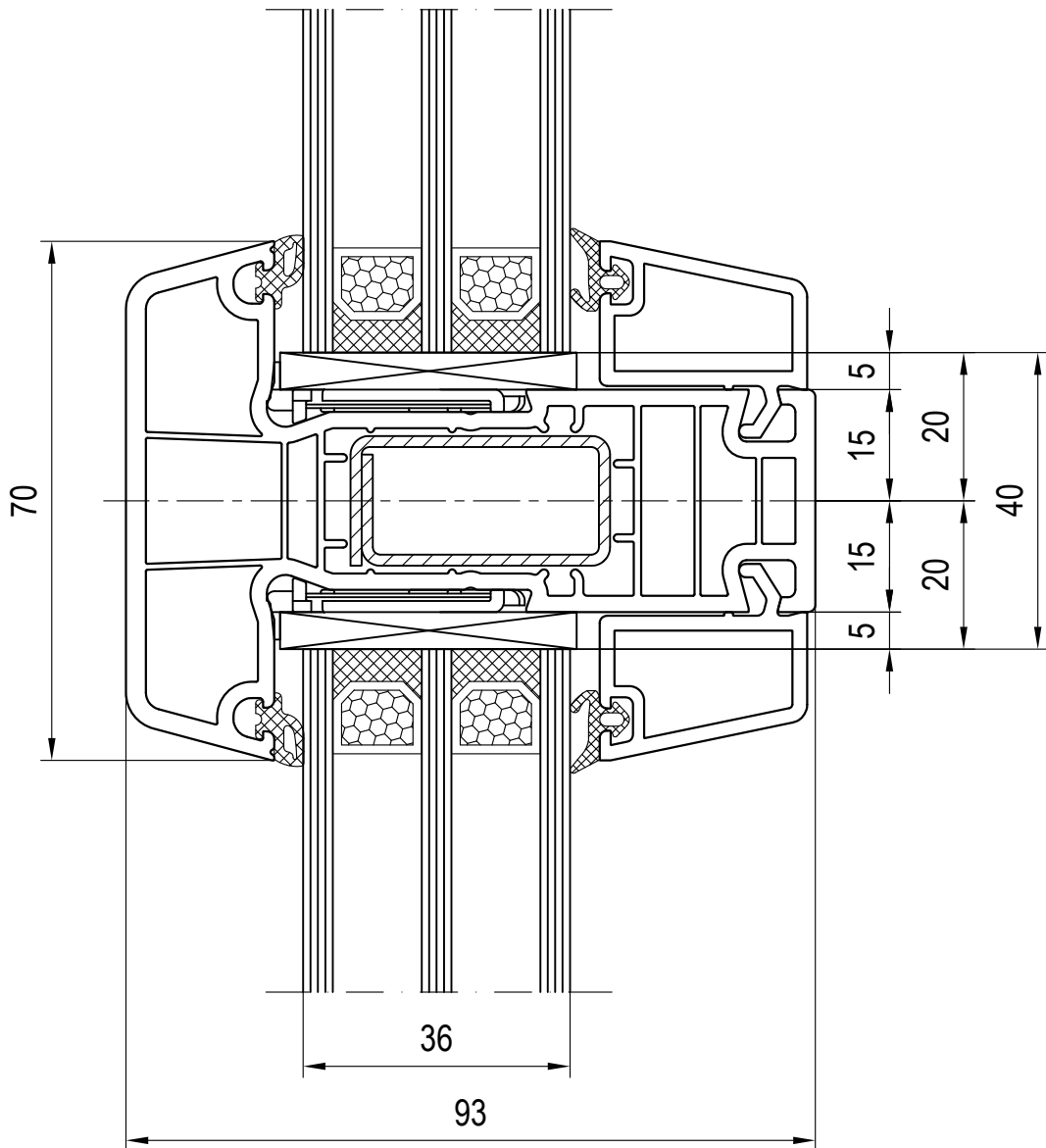

transom

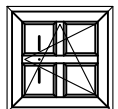

-> sash 180x26  
 -> false mullion sash 180x69

May be subject to change  
 and errors excepted!

scale: 1:1  
 03\_K\_01\_8\*

Combinations: Transom, Glazing-Divisive  
 Glazing Bead 120838/120868

Transom 180x47

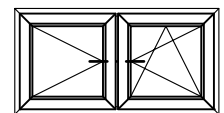
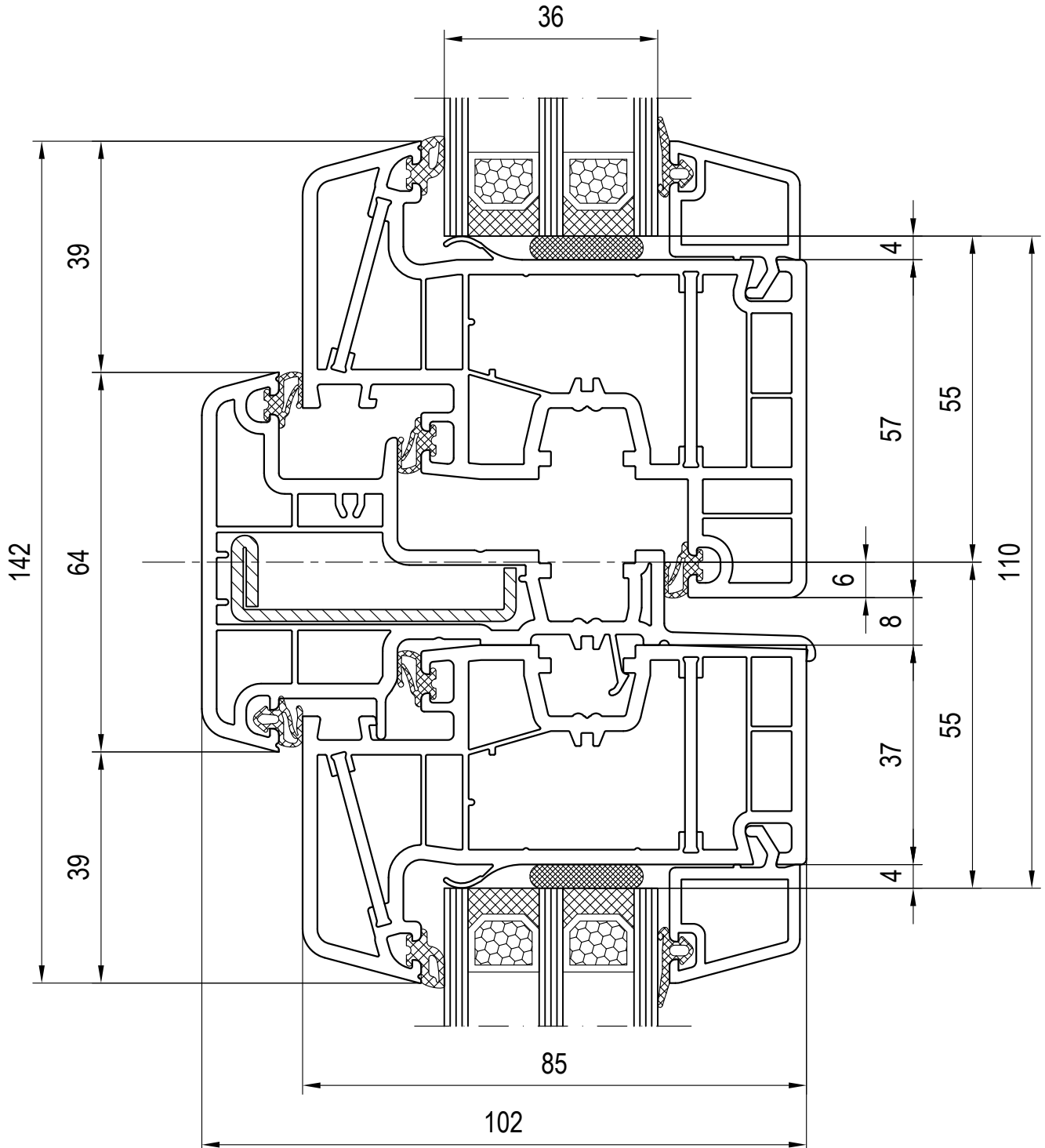

May be subject to change and errors excepted!

scale: 1:1  
03\_L\_01\_8\*

Combinations: Sash - False Mullion - Sash  
Glazing Bead 120636/120666

**False Mullion 180x64**  
**Sash 080x86**

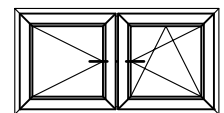
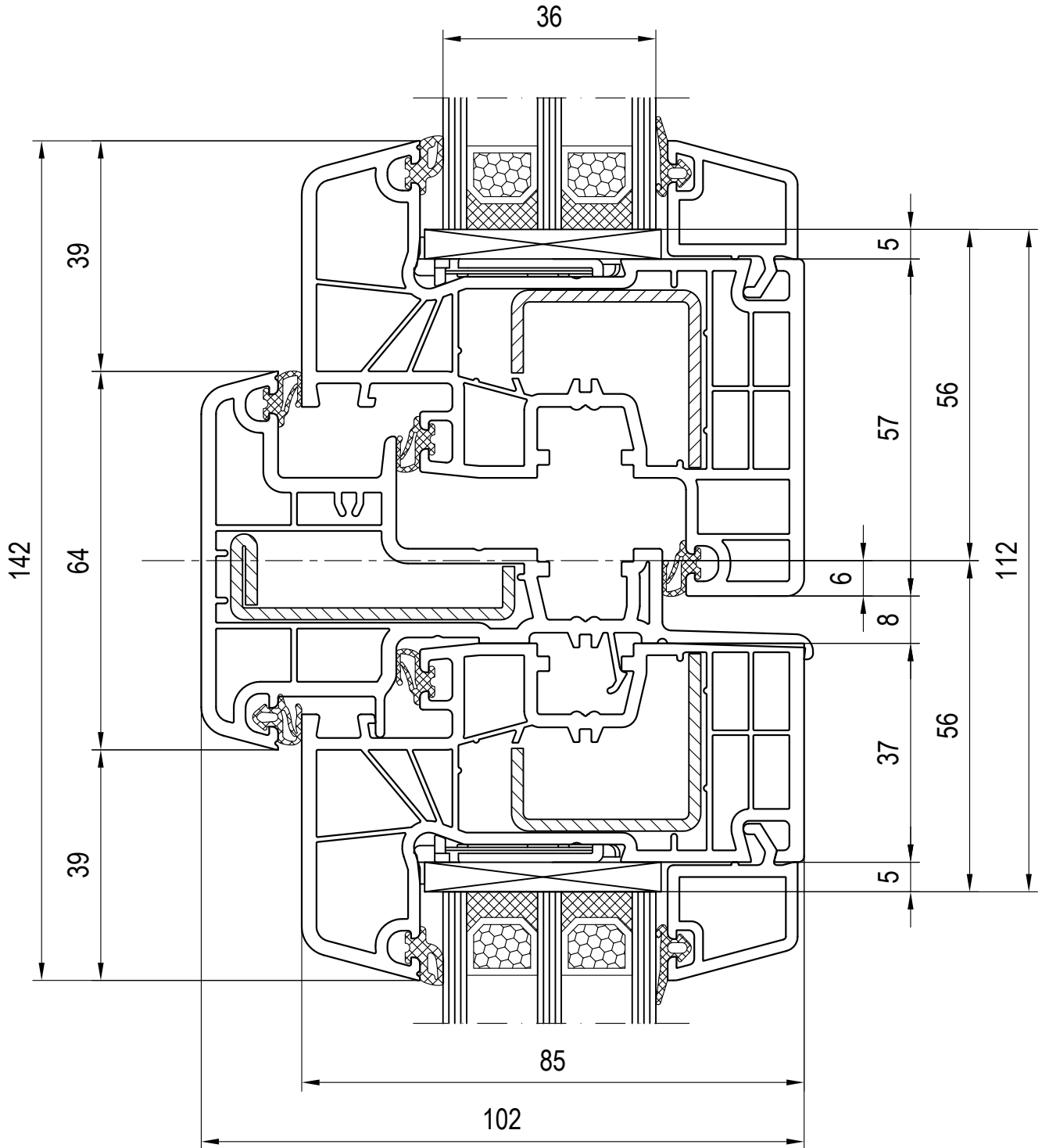

May be subject to change  
 and errors excepted!  
 scale: 1:1  
 03\_L\_01\_8\*

Combinations: Sash - False Mullion - Sash  
 Glazing Bead 120636/120666

**False Mullion 180x64**  
**Sash 180x20**



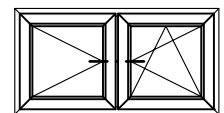
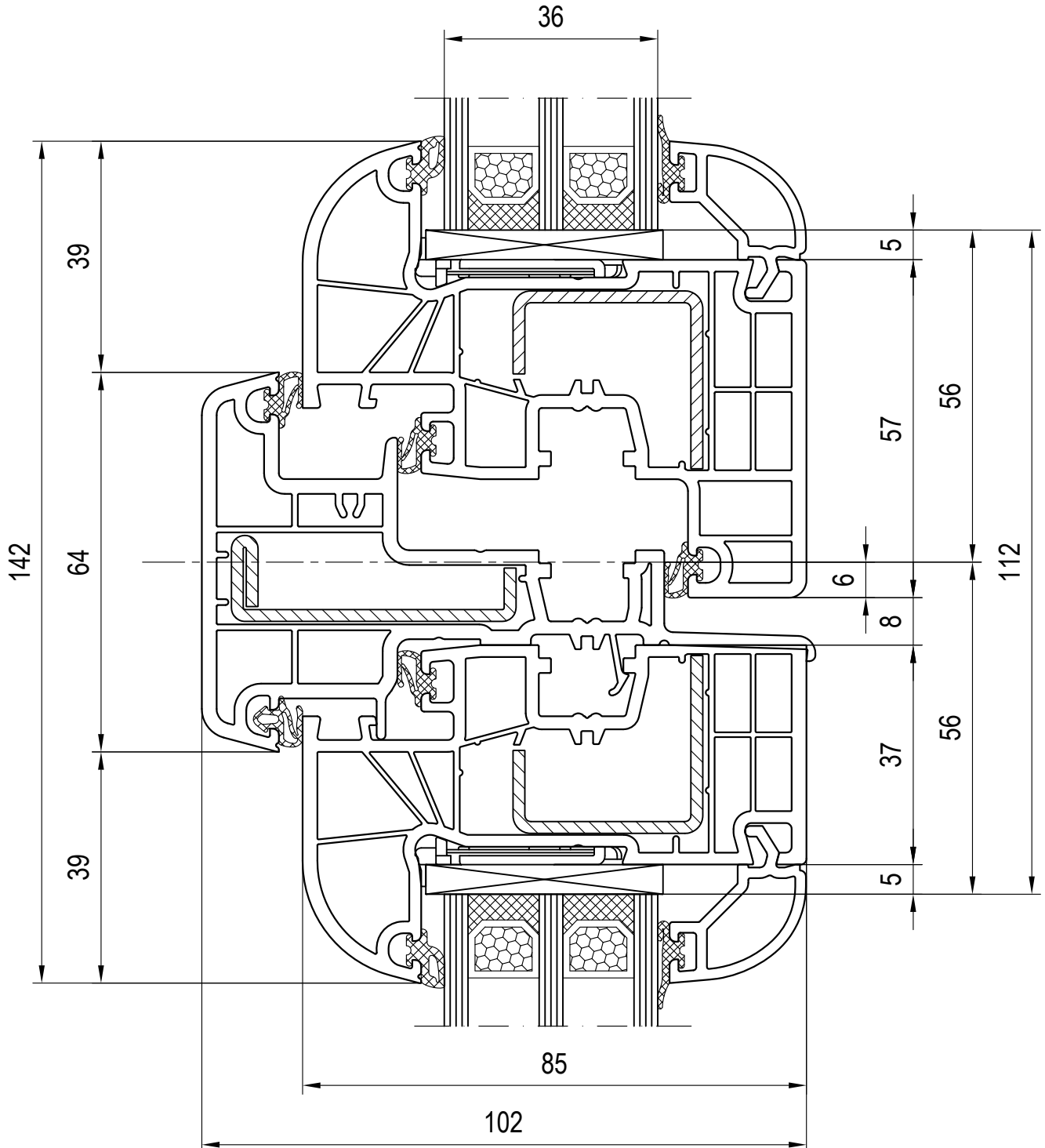

May be subject to change and errors excepted!

scale: 1:1  
03\_L\_01\_8\*

Combinations: Sash - False Mullion - Sash  
Glazing Bead 120650/120680

False Mullion 180x64  
Sash 180x22

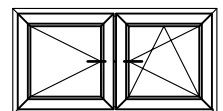
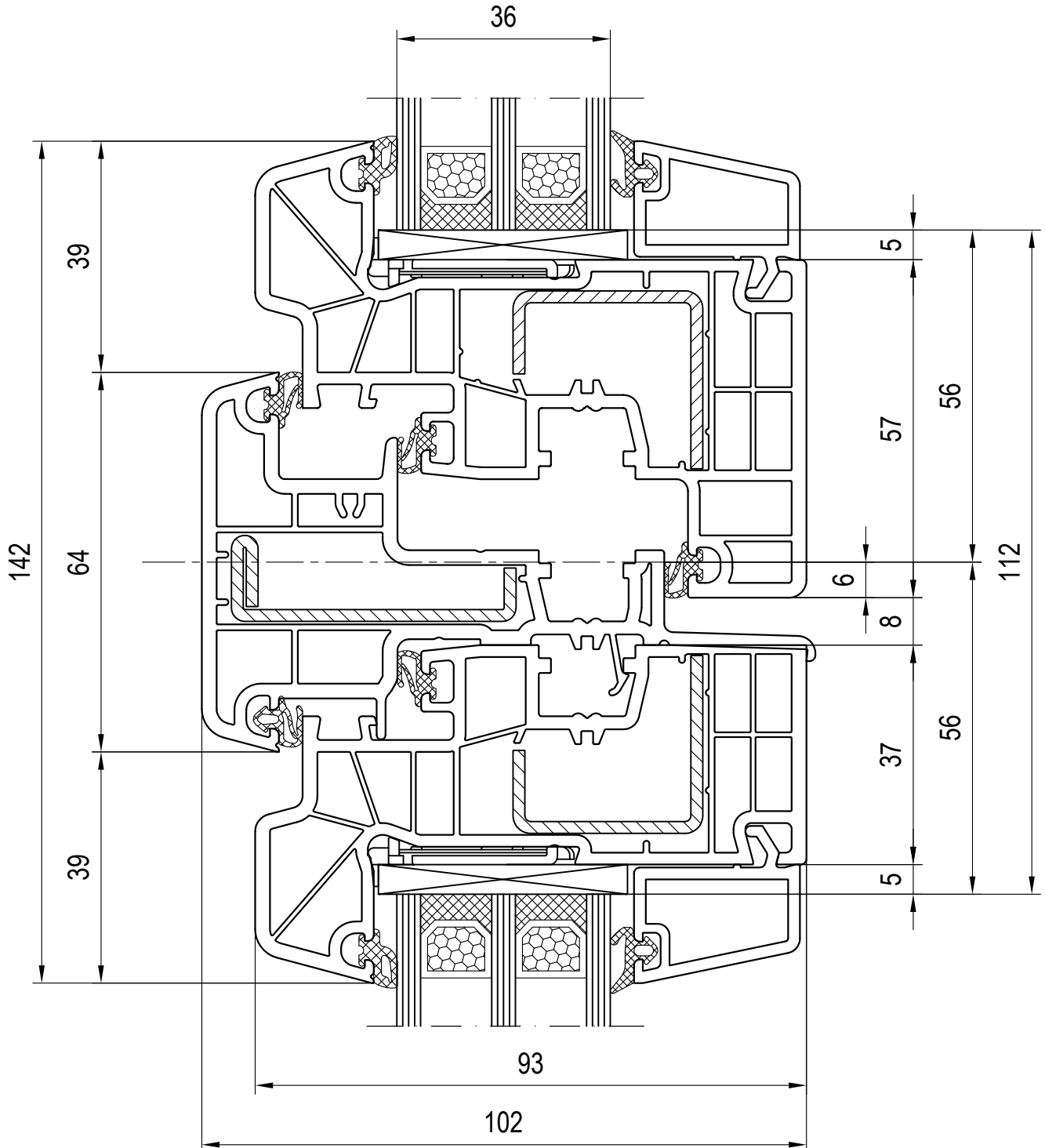

May be subject to change  
and errors excepted!

scale: 1:1  
03\_L\_01\_8\*

Combinations: Sash - False Mullion - Sash  
Glazing Bead 120838/120868

False Mullion 180x64  
Sash 180x26

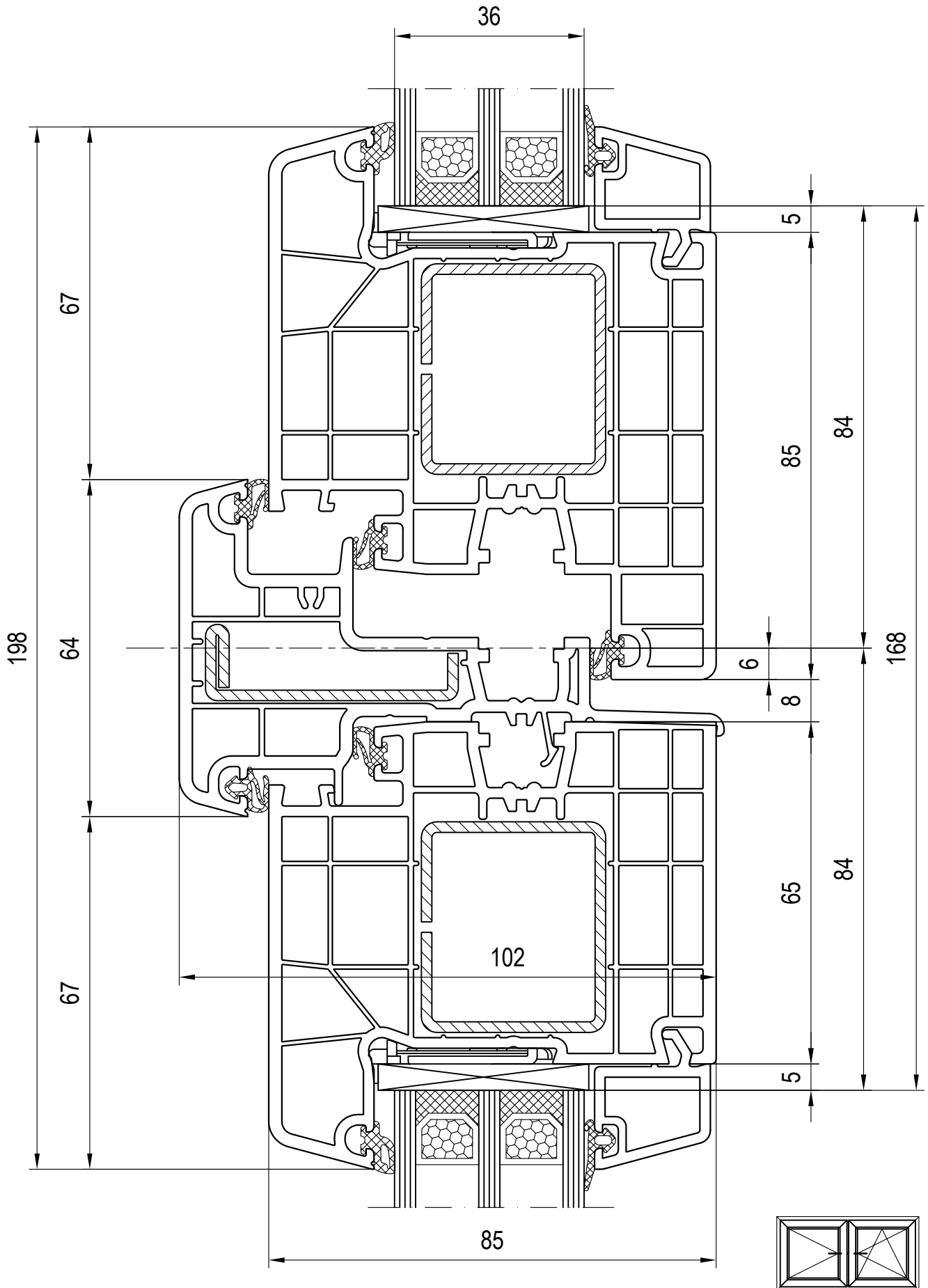

May be subject to change and errors excepted!

scale: 1:1  
03\_L\_01\_8\*

Combinations: Sash - False Mullion - Sash  
Glazing Bead 120636/120666

False Mullion 180x64  
Sash 180x30

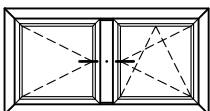
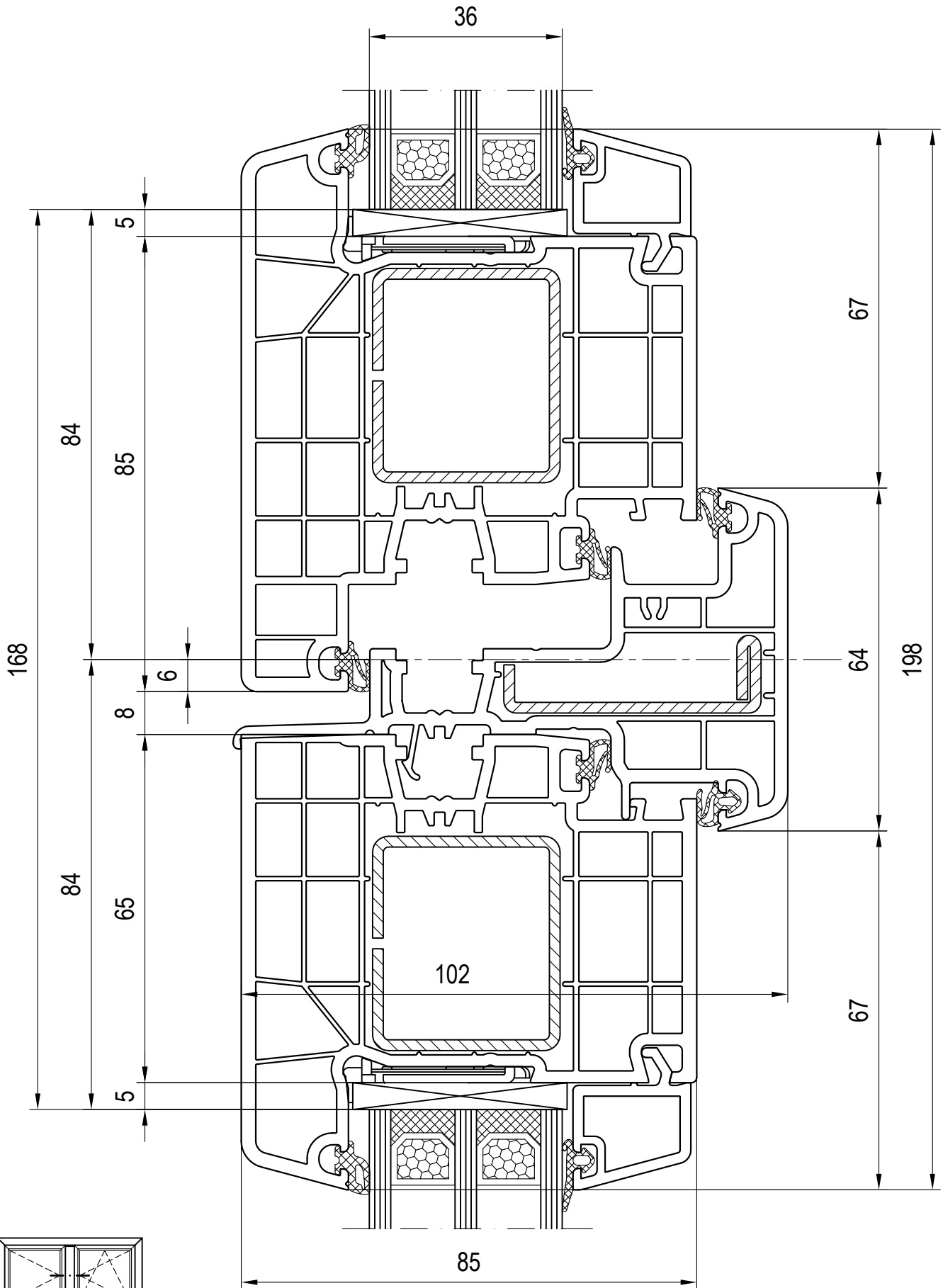

May be subject to change  
and errors excepted!

scale: 1:1  
03\_L\_01\_8\*

Combinations: Sash - False Mullion - Sash  
Glazing Bead 120636/120666

False Mullion 180x64  
Sash 180x31

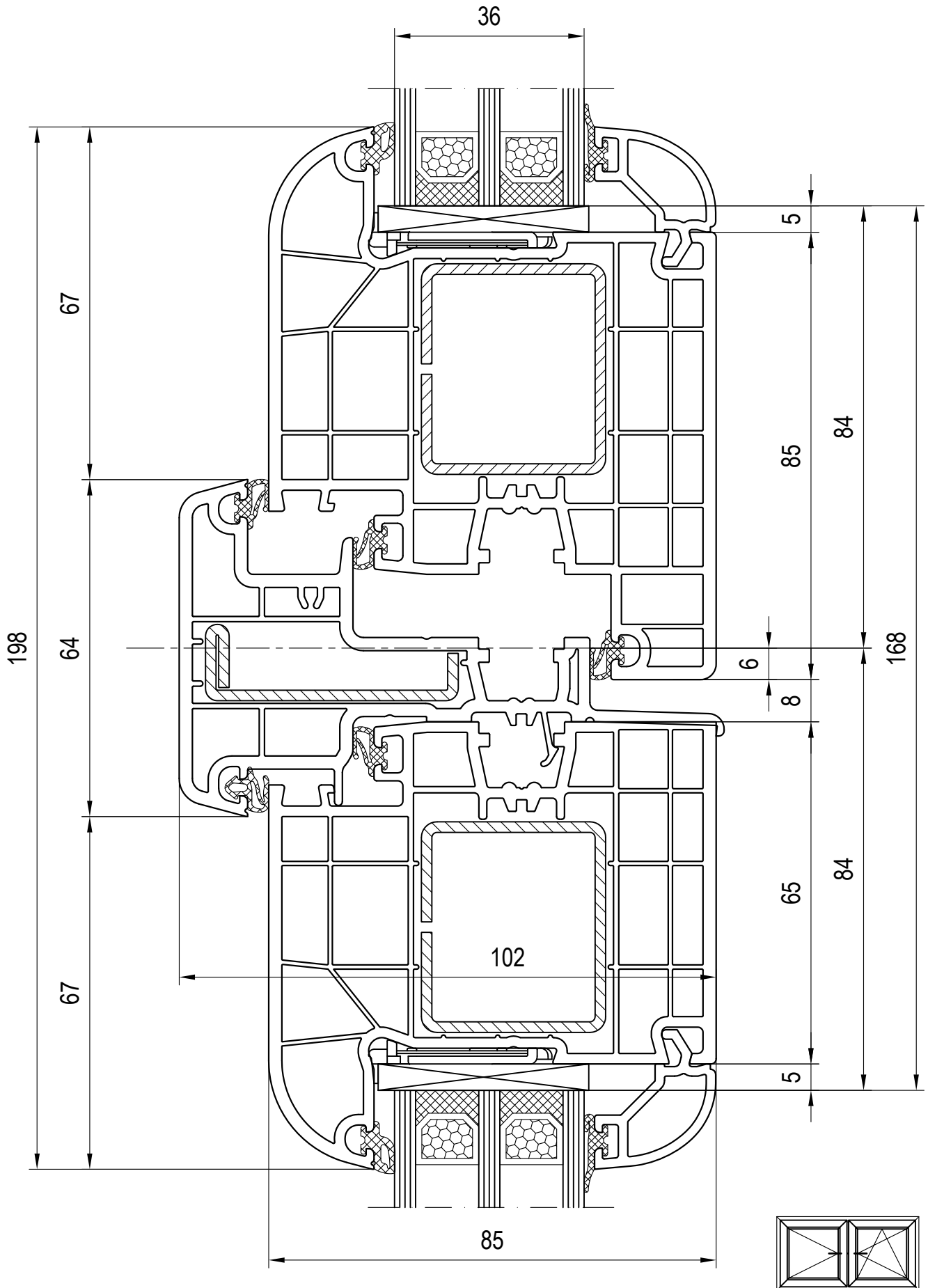

May be subject to change and errors excepted!

scale: 1:1  
03\_L\_01\_8\*

Combinations: Sash - False Mullion - Sash  
Glazing Bead 120650/120680

**False Mullion 180x64**  
**Sash 180x32**

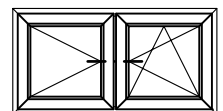
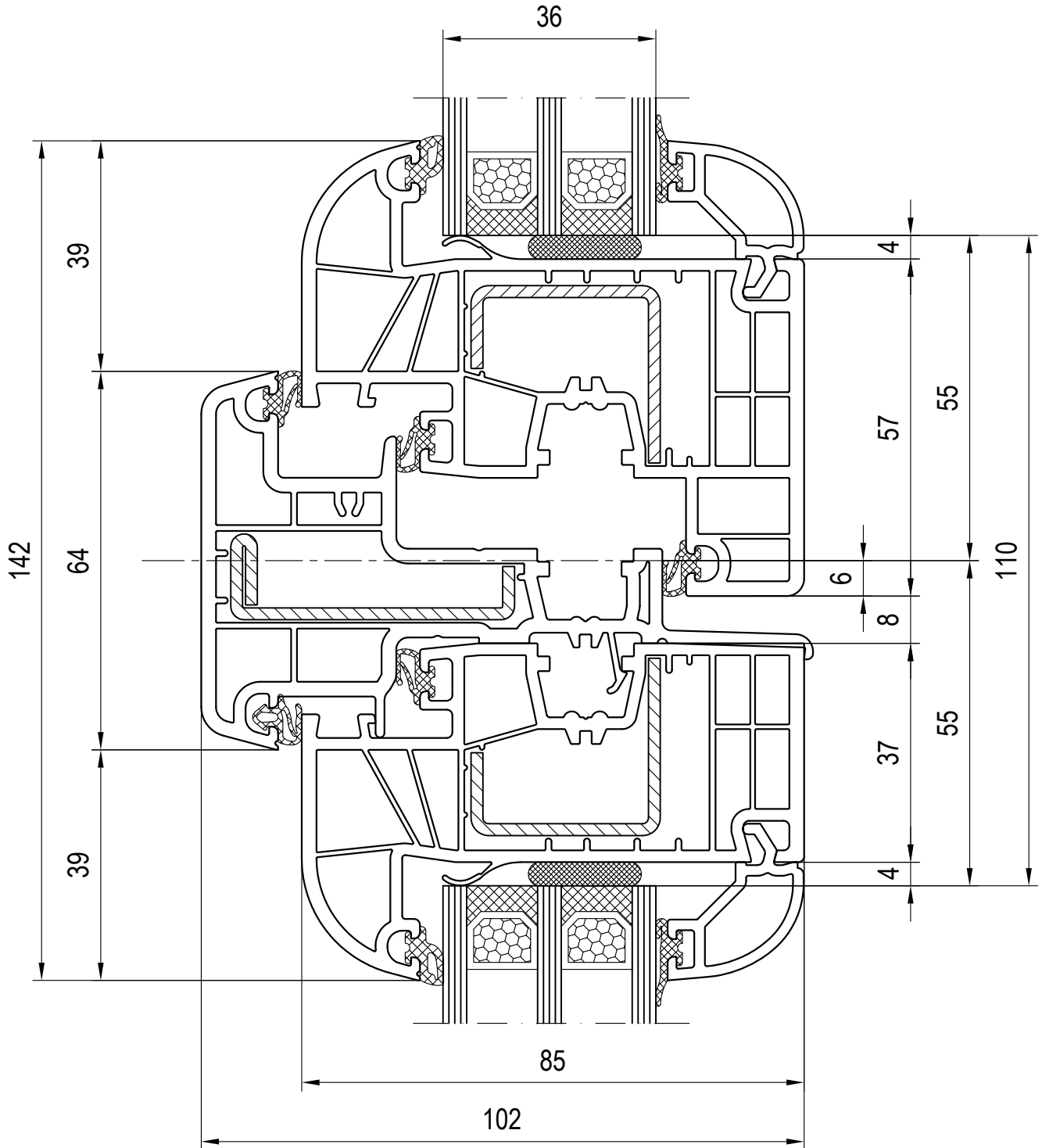

May be subject to change  
and errors excepted!

scale: 1:1  
03\_L\_01\_8\*

Combinations: Sash - False Mullion - Sash  
Glazing Bead 120650/120680

False Mullion 180x64  
Sash 180x83

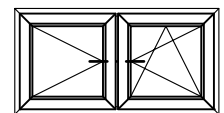
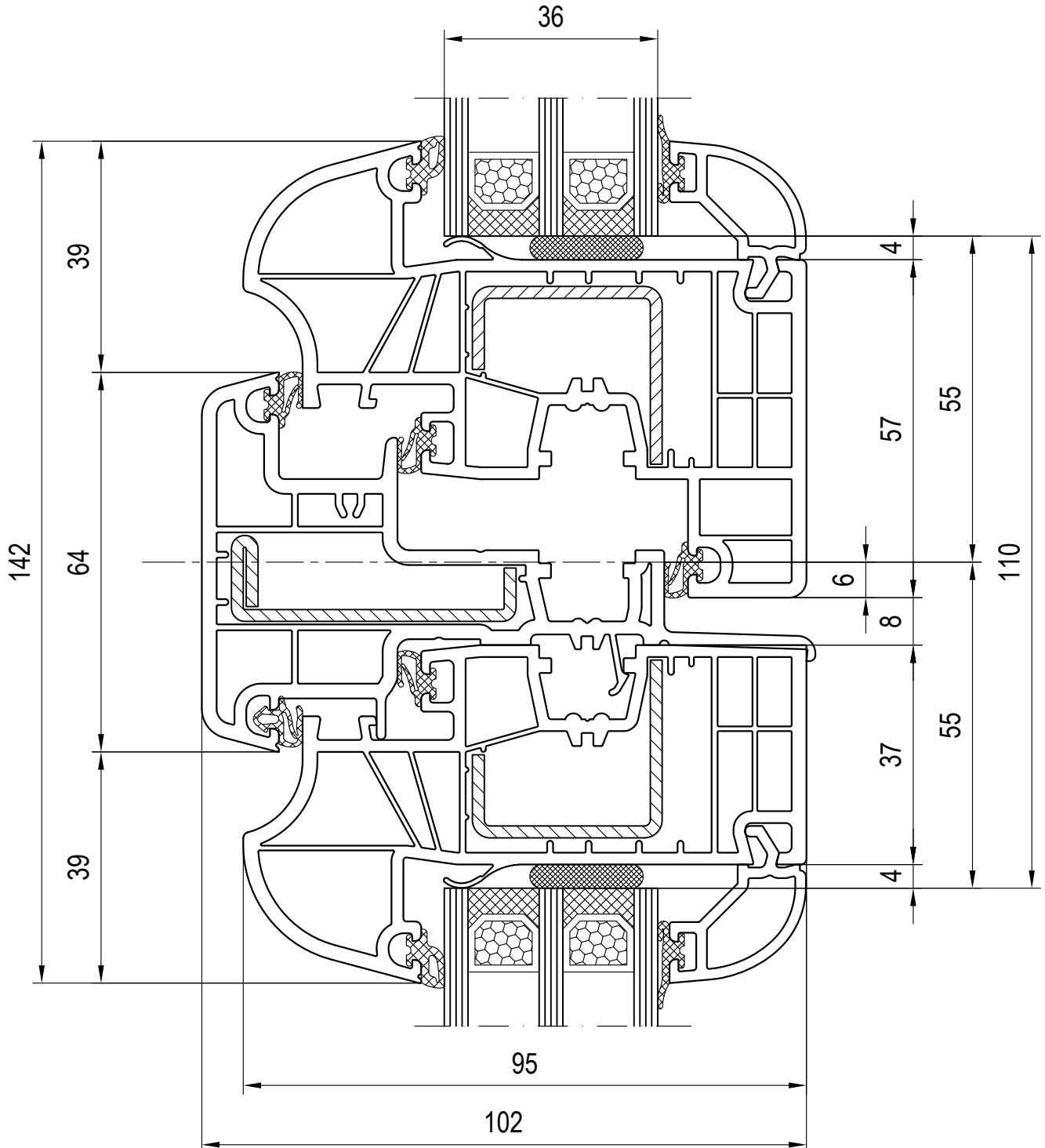

May be subject to change  
and errors excepted!

scale: 1:1  
03\_L\_01\_8\*

Combinations: Sash - False Mullion - Sash  
Glazing Bead 120650/120680

**False Mullion 180x64**  
**Sash 180x85**

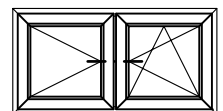
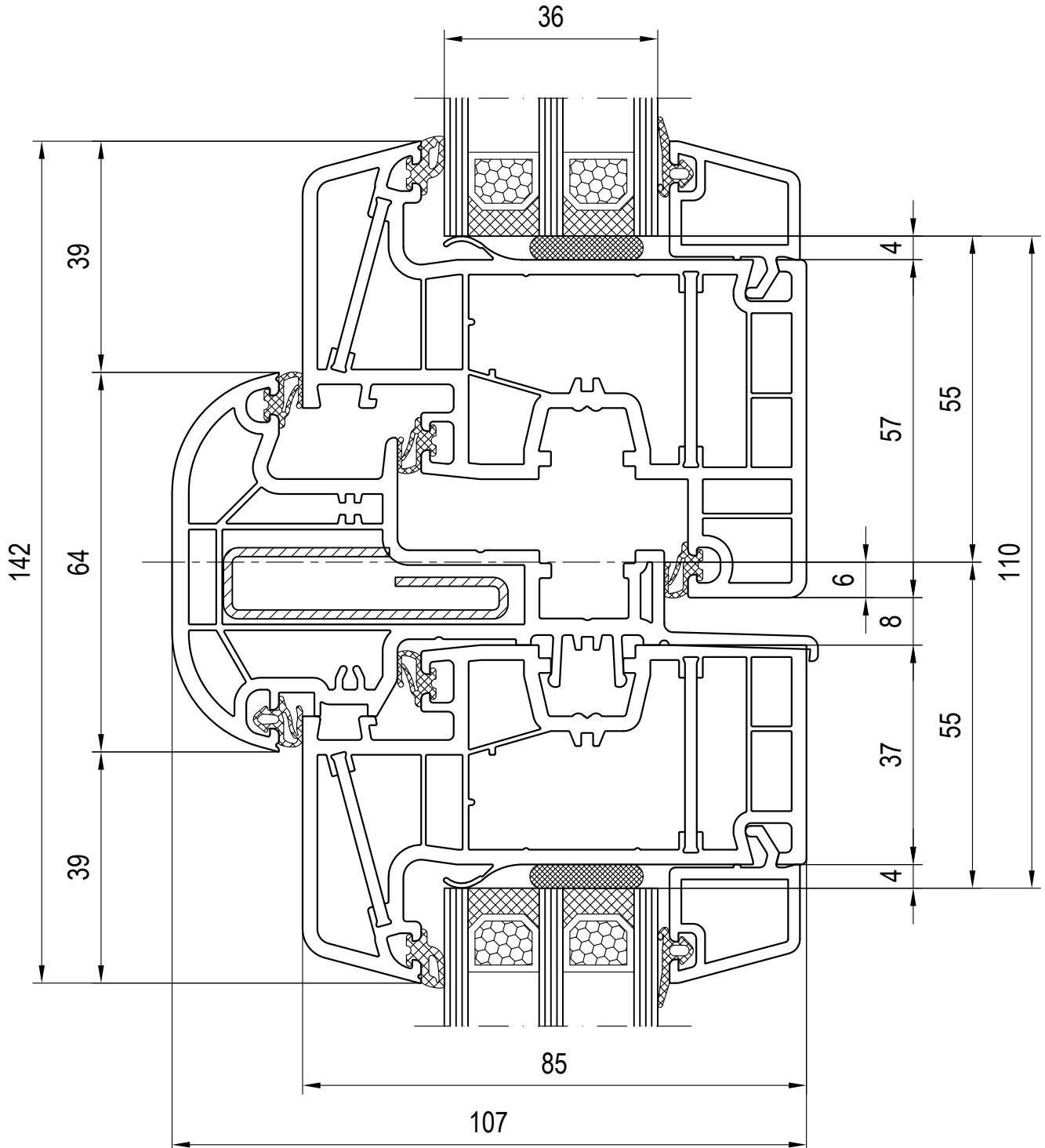

May be subject to change  
 and errors excepted!

scale: 1:1  
 03\_L\_01\_8\*

Combinations: Sash - False Mullion - Sash  
 Glazing Bead 120636/120666

**False Mullion 180x65**  
**Sash 080x86**



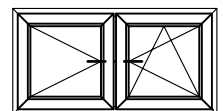
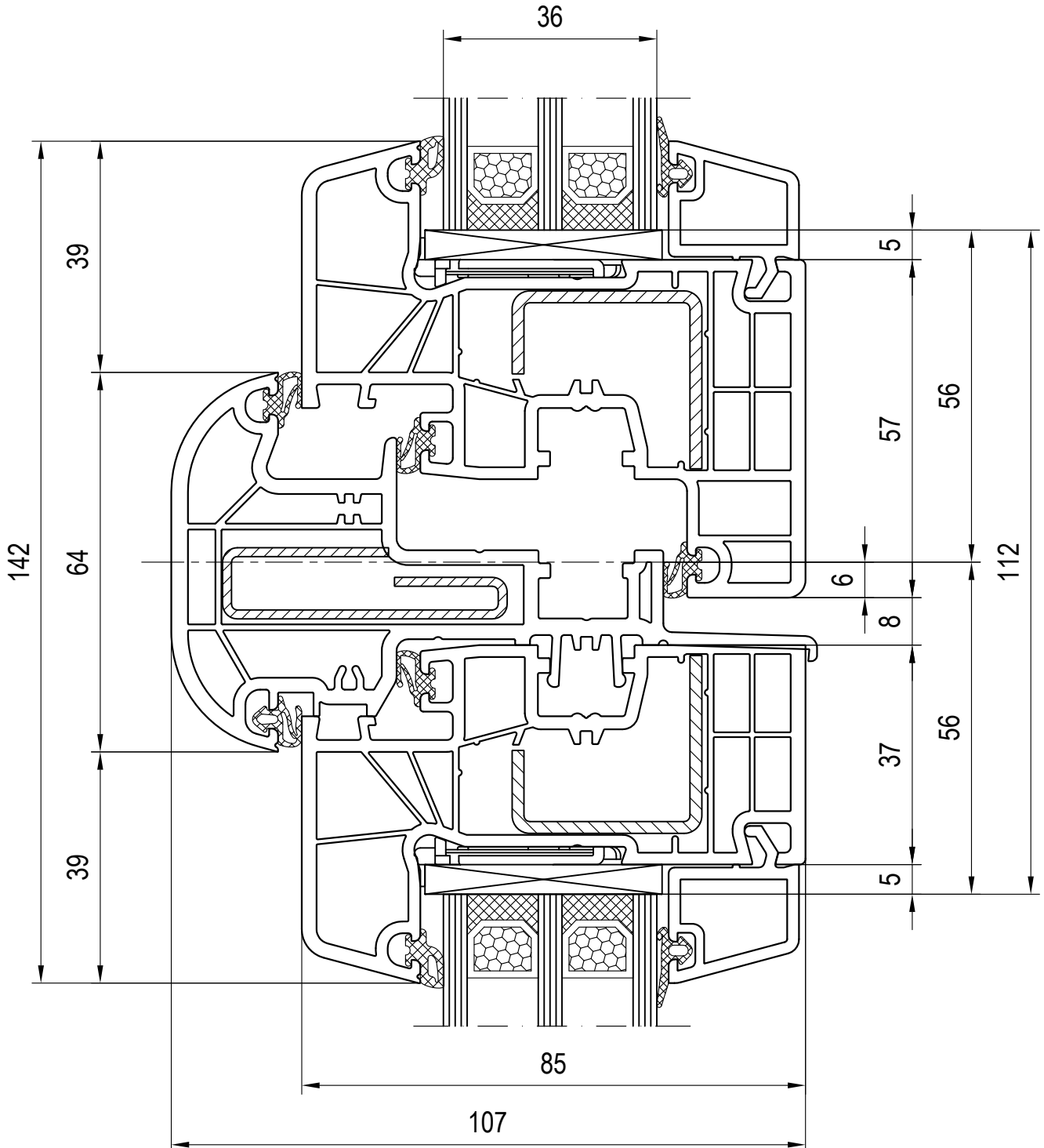

May be subject to change  
and errors excepted!

scale: 1:1  
03\_L\_01\_8\*

Combinations: Sash - False Mullion - Sash  
Glazing Bead 120636/120666

False Mullion 180x65  
Sash 180x20

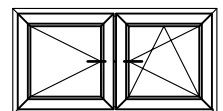
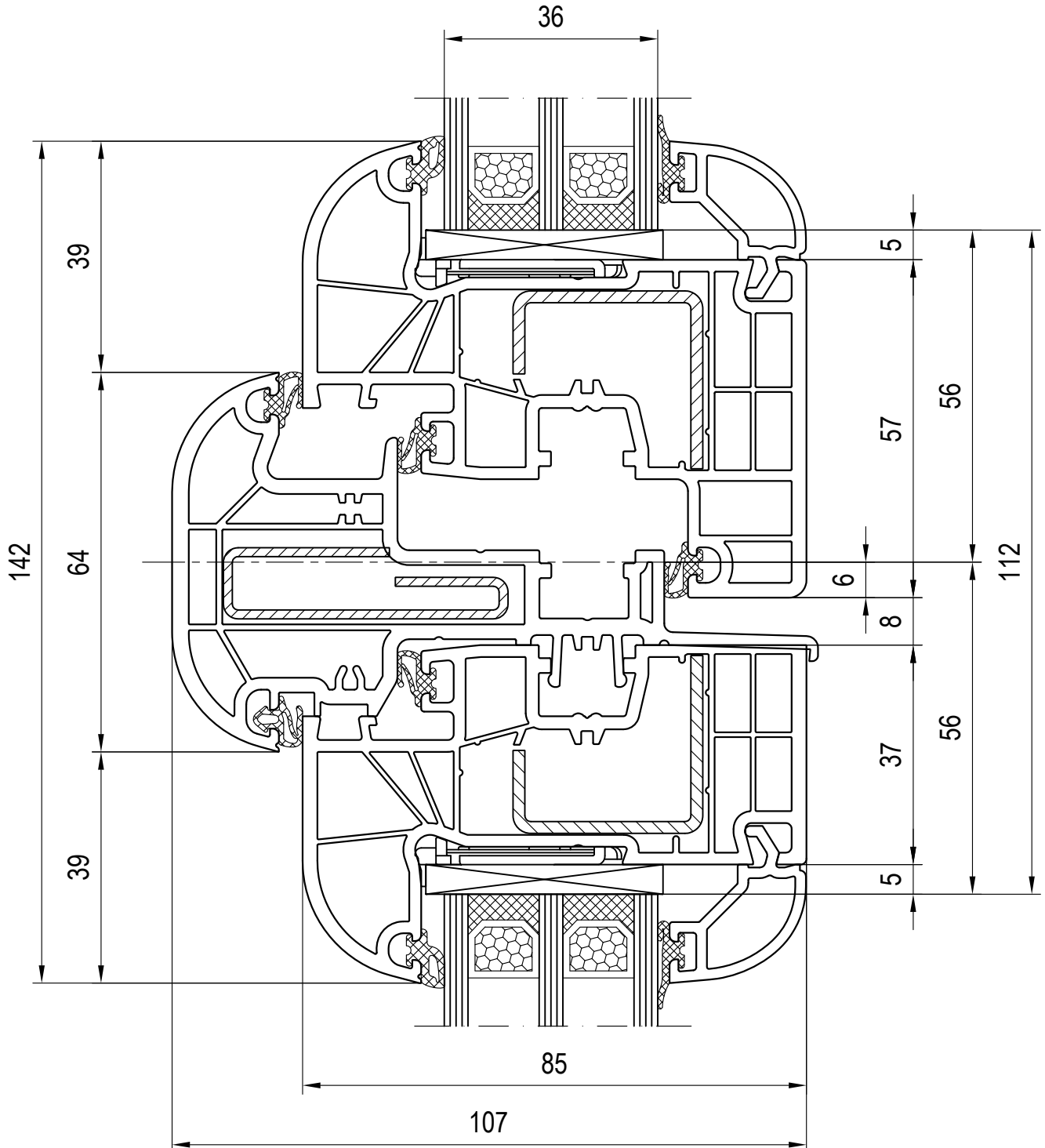

May be subject to change  
 and errors excepted!

scale: 1:1  
 03\_L\_01\_8\*

Combinations: Sash - False Mullion - Sash  
 Glazing Bead 120650/120680

**False Mullion 180x65**  
**Sash 180x22**

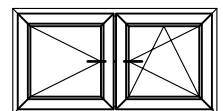
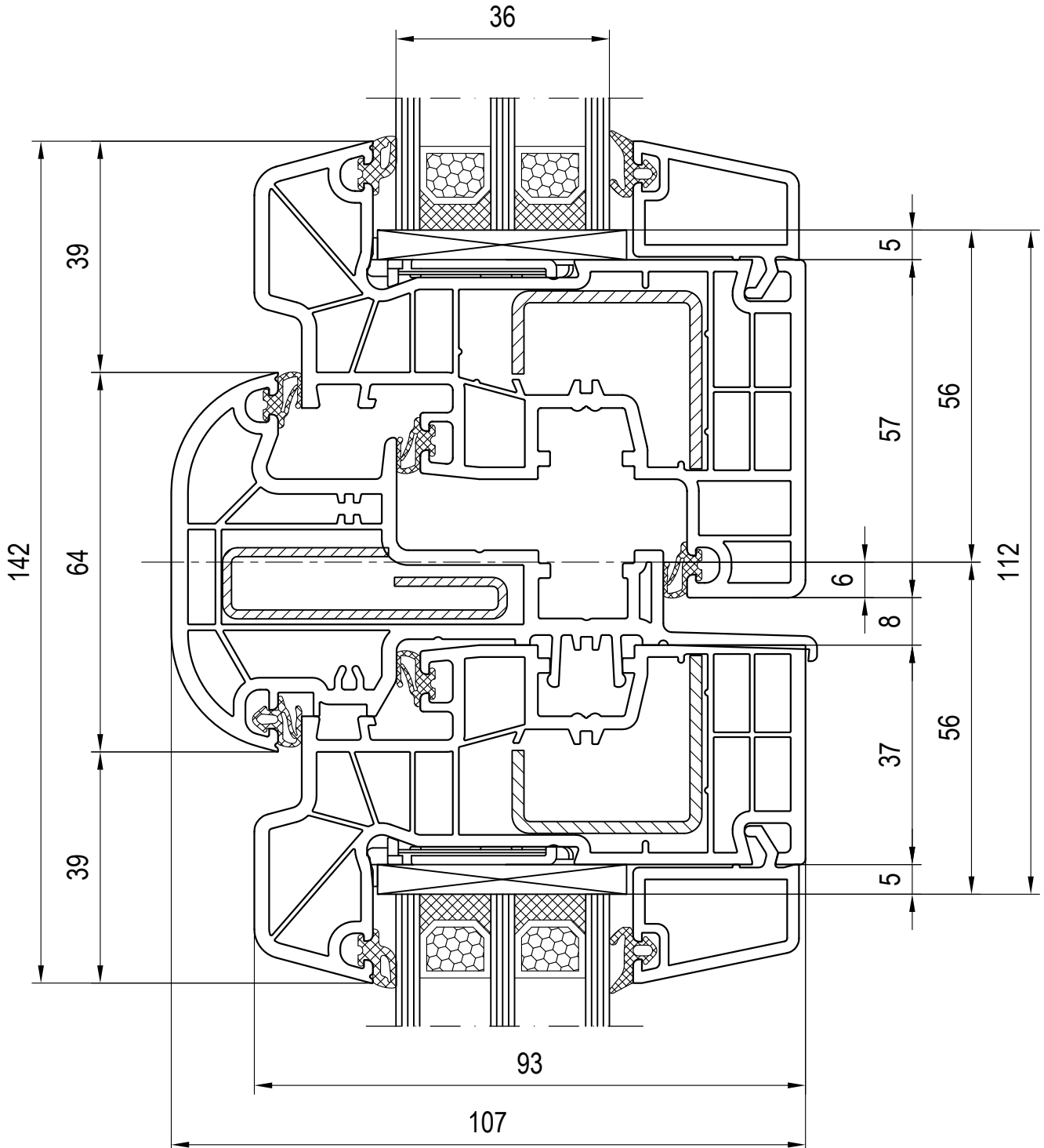

May be subject to change  
and errors excepted!

scale: 1:1  
03\_L\_01\_8\*

Combinations: Sash - False Mullion - Sash  
Glazing Bead 120838/120868

False Mullion 180x65  
Sash 180x26

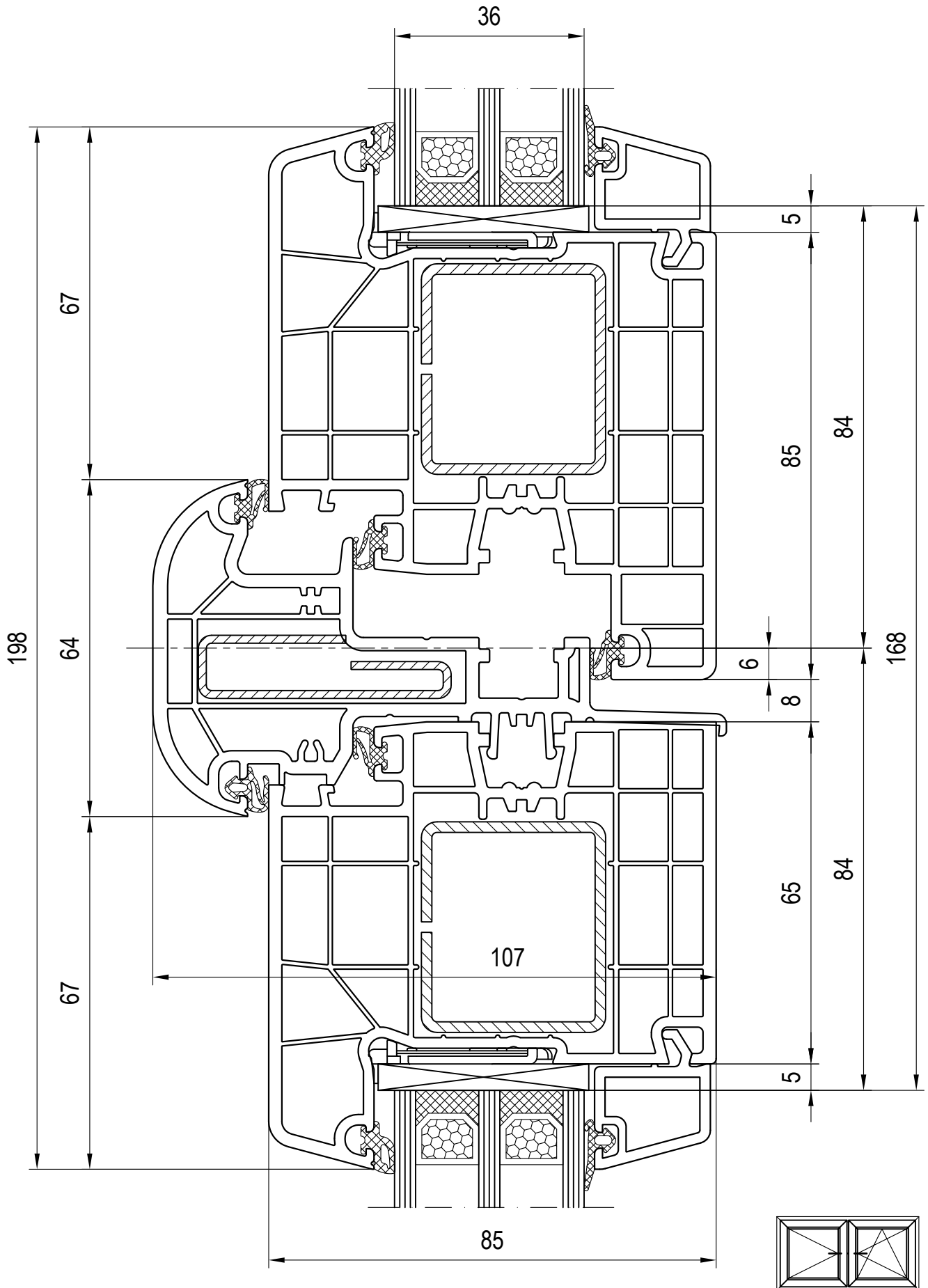

May be subject to change  
 and errors excepted!  
 scale: 1:1  
 03\_L\_01\_8\*

Combinations: Sash - False Mullion - Sash  
 Glazing Bead 120636/120666

**False Mullion 180x65**  
**Sash 180x30**

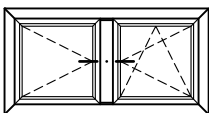
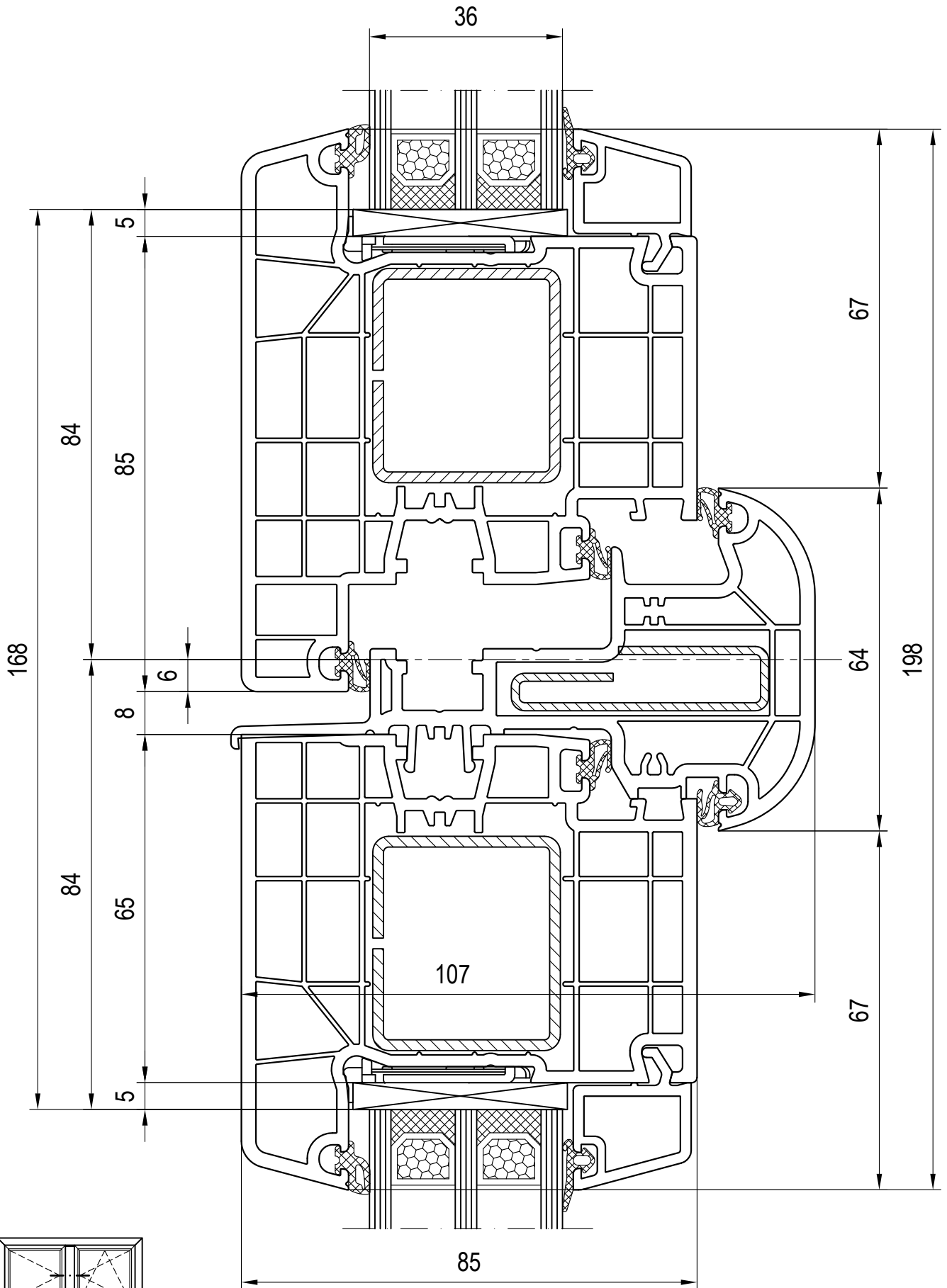

May be subject to change  
and errors excepted!

scale: 1:1  
03\_L\_01\_8\*

Combinations: Sash - False Mullion - Sash  
Glazing Bead 120636/120666

False Mullion 180x65  
Sash 180x31

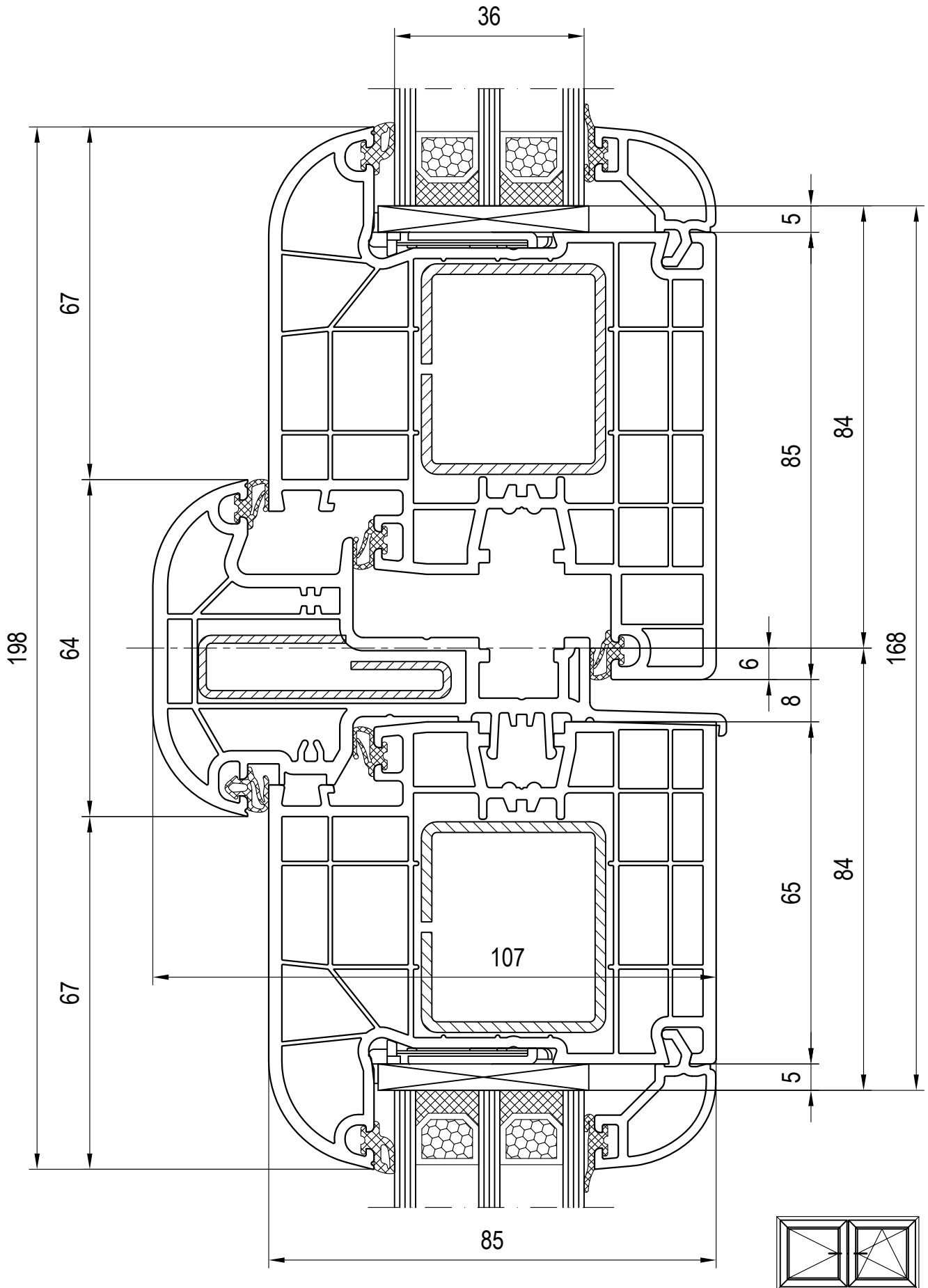

May be subject to change and errors excepted!

scale: 1:1  
 03\_L\_01\_8\*

Combinations: Sash - False Mullion - Sash  
 Glazing Bead 120650/120680

False Mullion 180x65  
 Sash 180x32

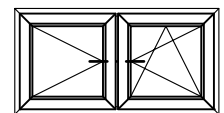
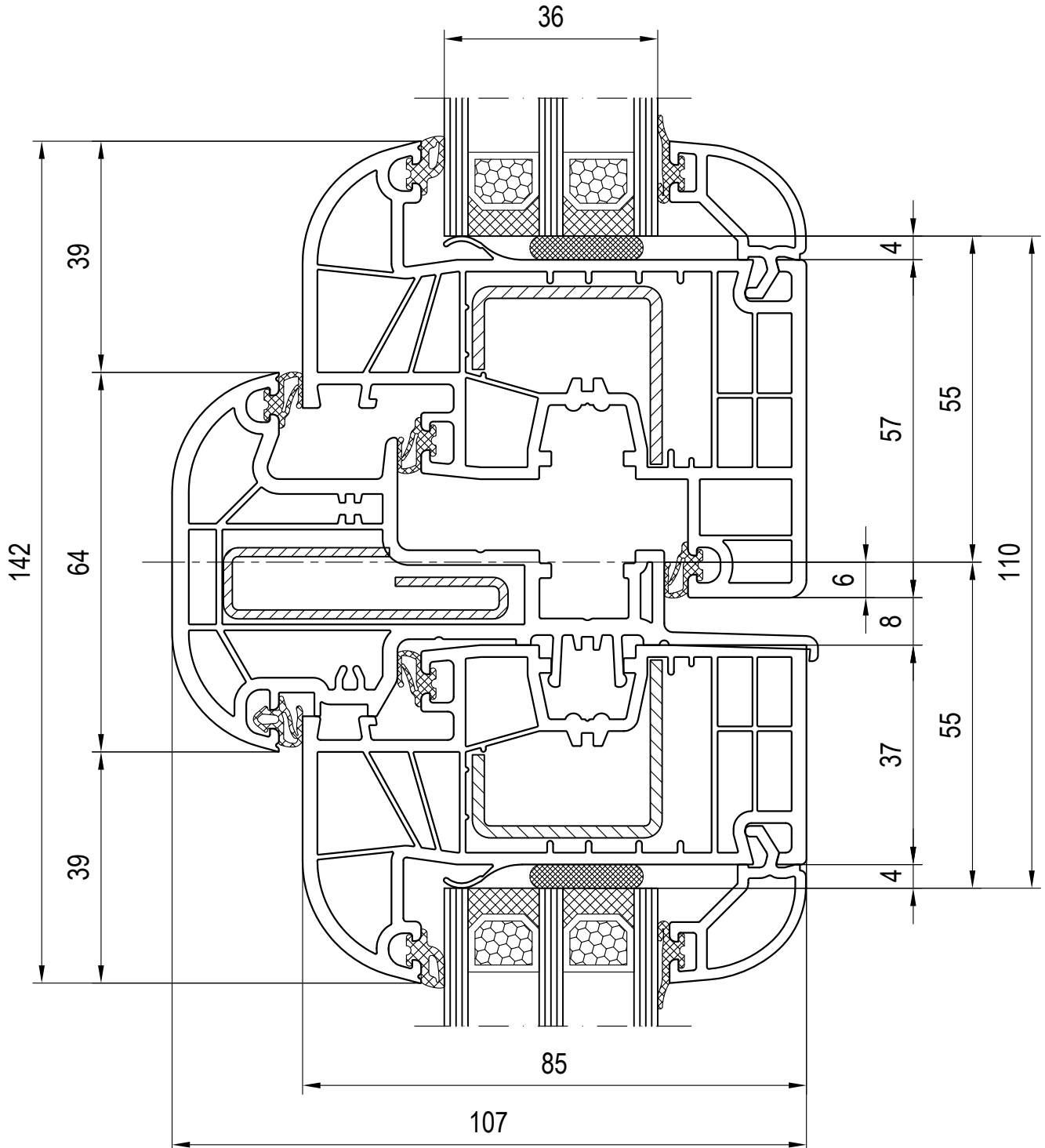

May be subject to change and errors excepted!

scale: 1:1  
 03\_L\_01\_8\*

Combinations: Sash - False Mullion - Sash  
 Glazing Bead 120650/120680

**False Mullion 180x65**  
**Sash 180x83**

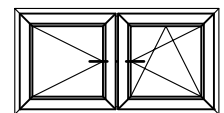
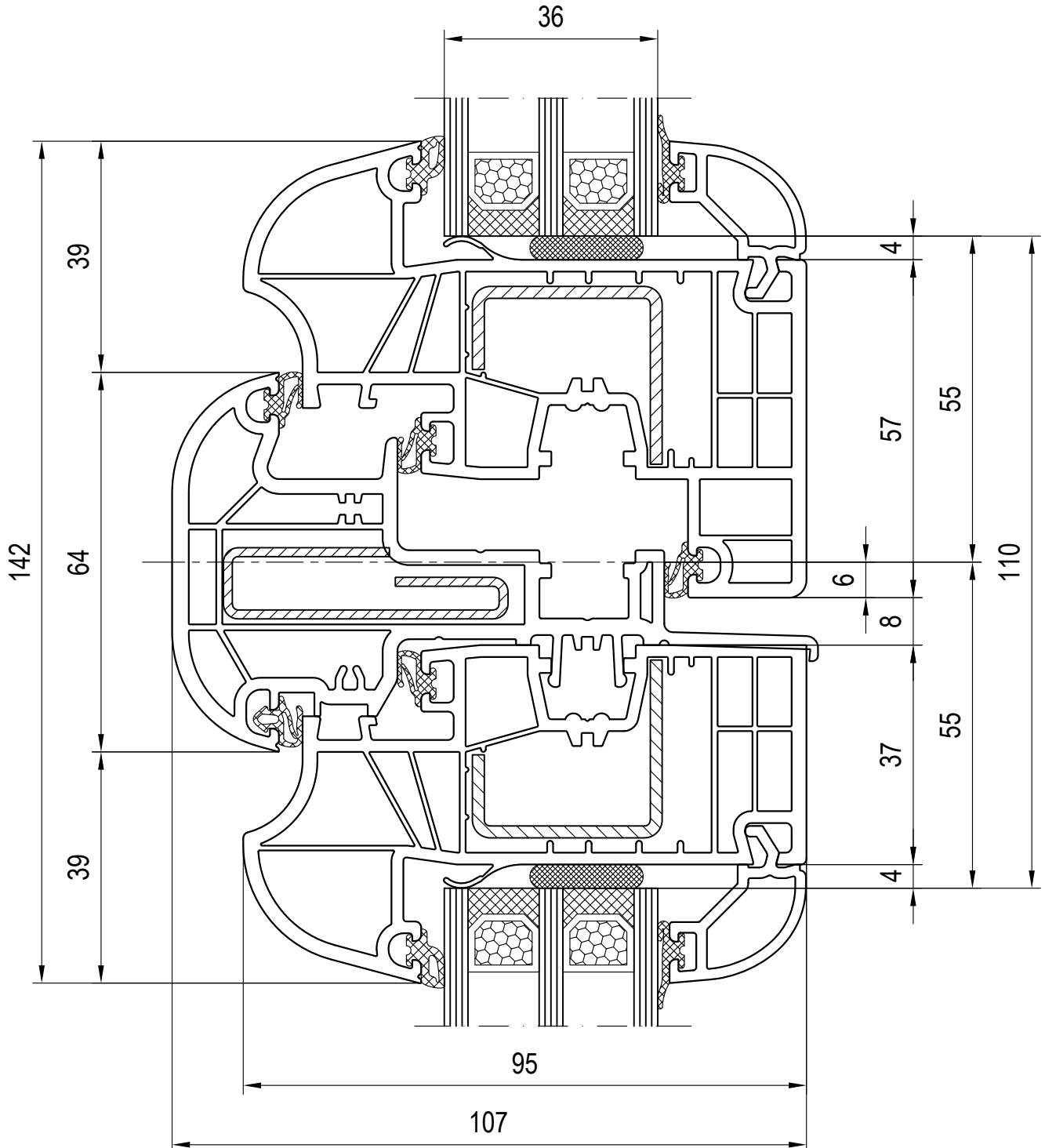

May be subject to change  
 and errors excepted!

scale: 1:1  
 03\_L\_01\_8\*

Combinations: Sash - False Mullion - Sash  
 Glazing Bead 120650/120680

**False Mullion 180x65**  
**Sash 180x85**



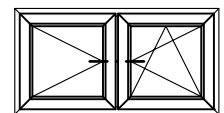
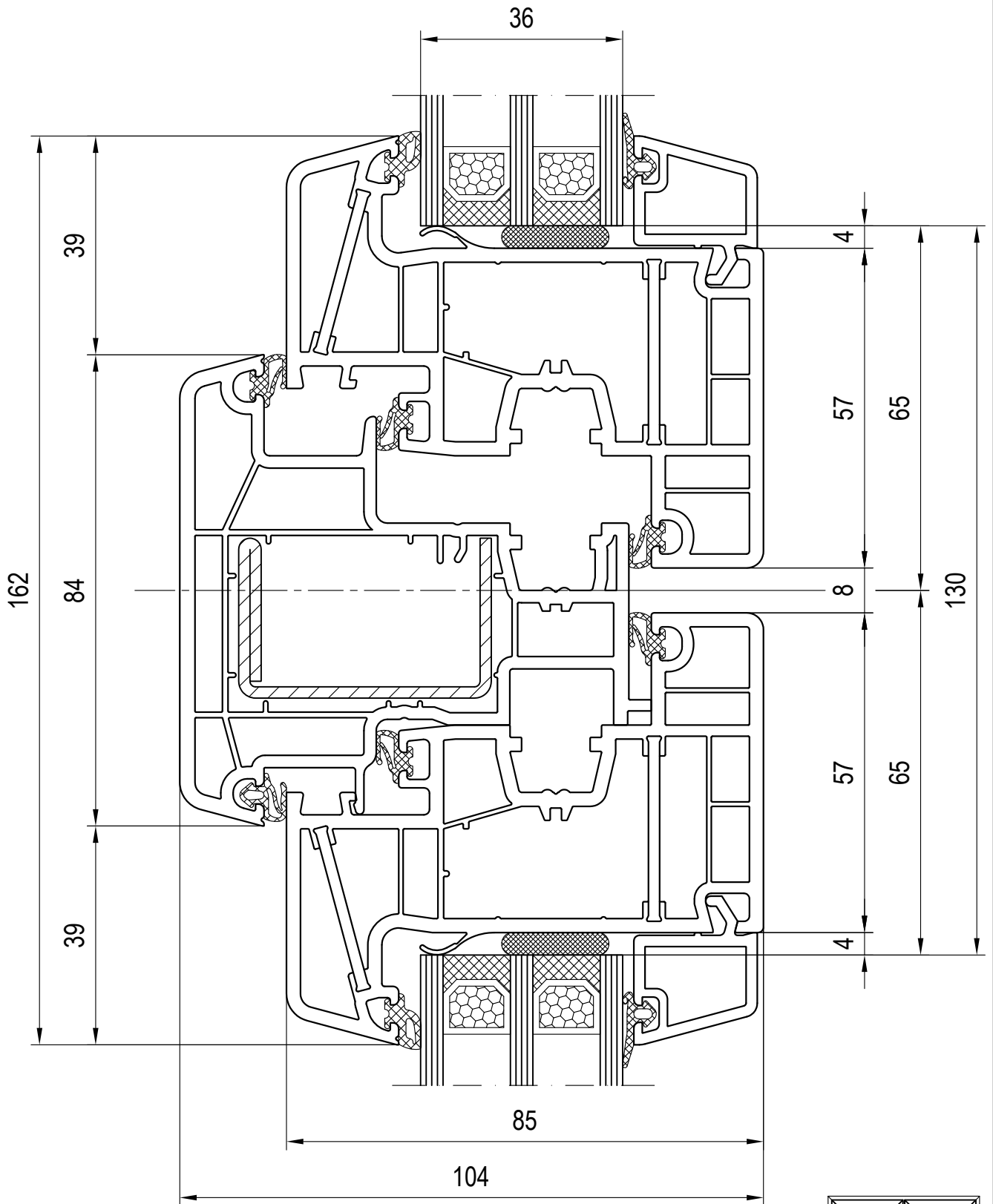

May be subject to change  
and errors excepted!  
scale: 1:1  
03\_L\_01\_8\*

Combinations: Sash - False Mullion - Sash  
Glazing Bead 120636/120666

**False Mullion 180x66**  
**Sash 080x86**

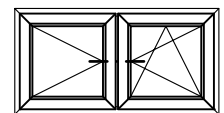
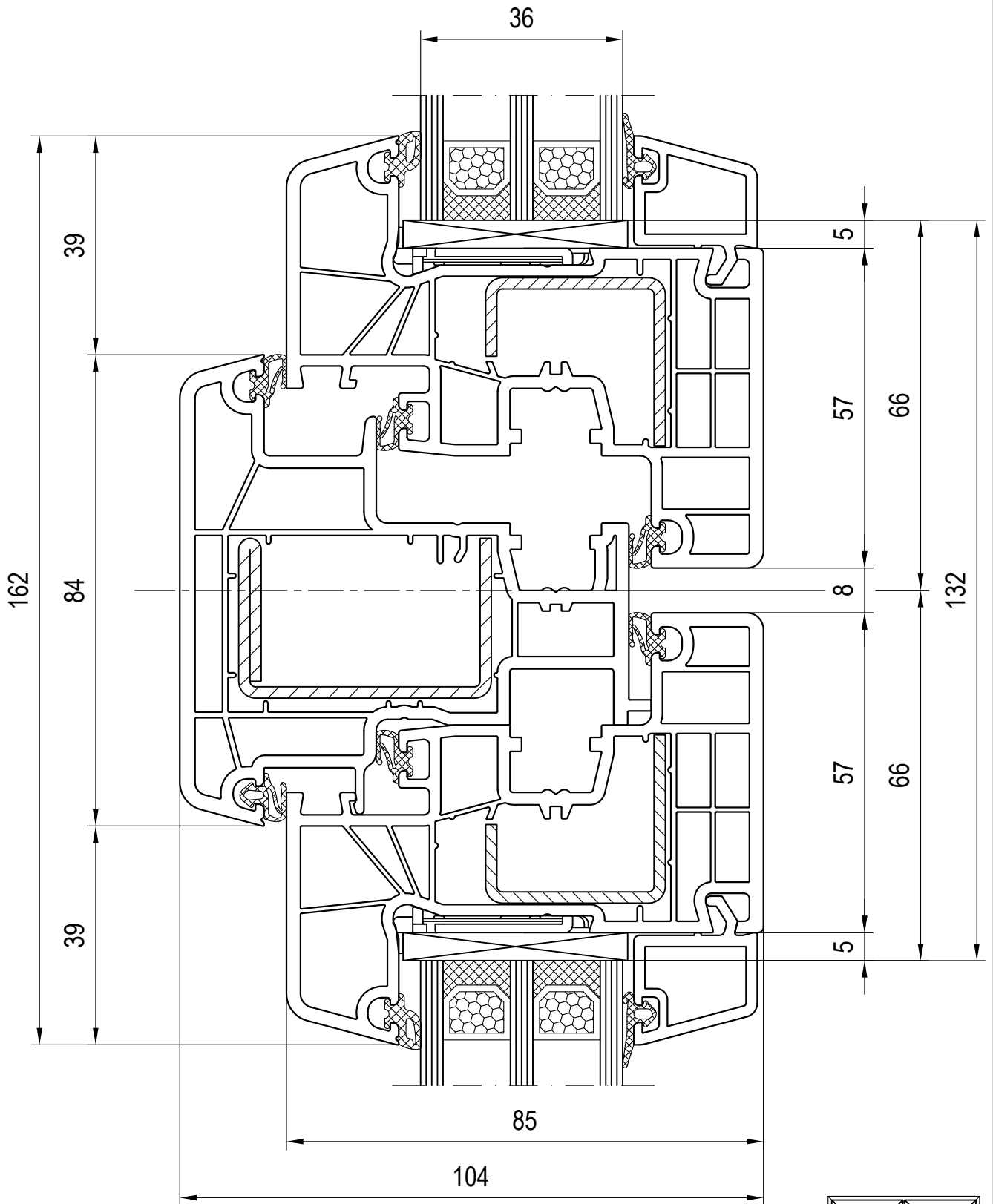

May be subject to change  
and errors excepted!  
scale: 1:1  
03\_L\_01\_8\*

Combinations: Sash - False Mullion - Sash  
Glazing Bead 120636/120666

False Mullion 180x66  
Sash 180x20

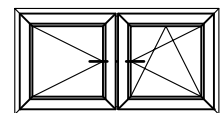
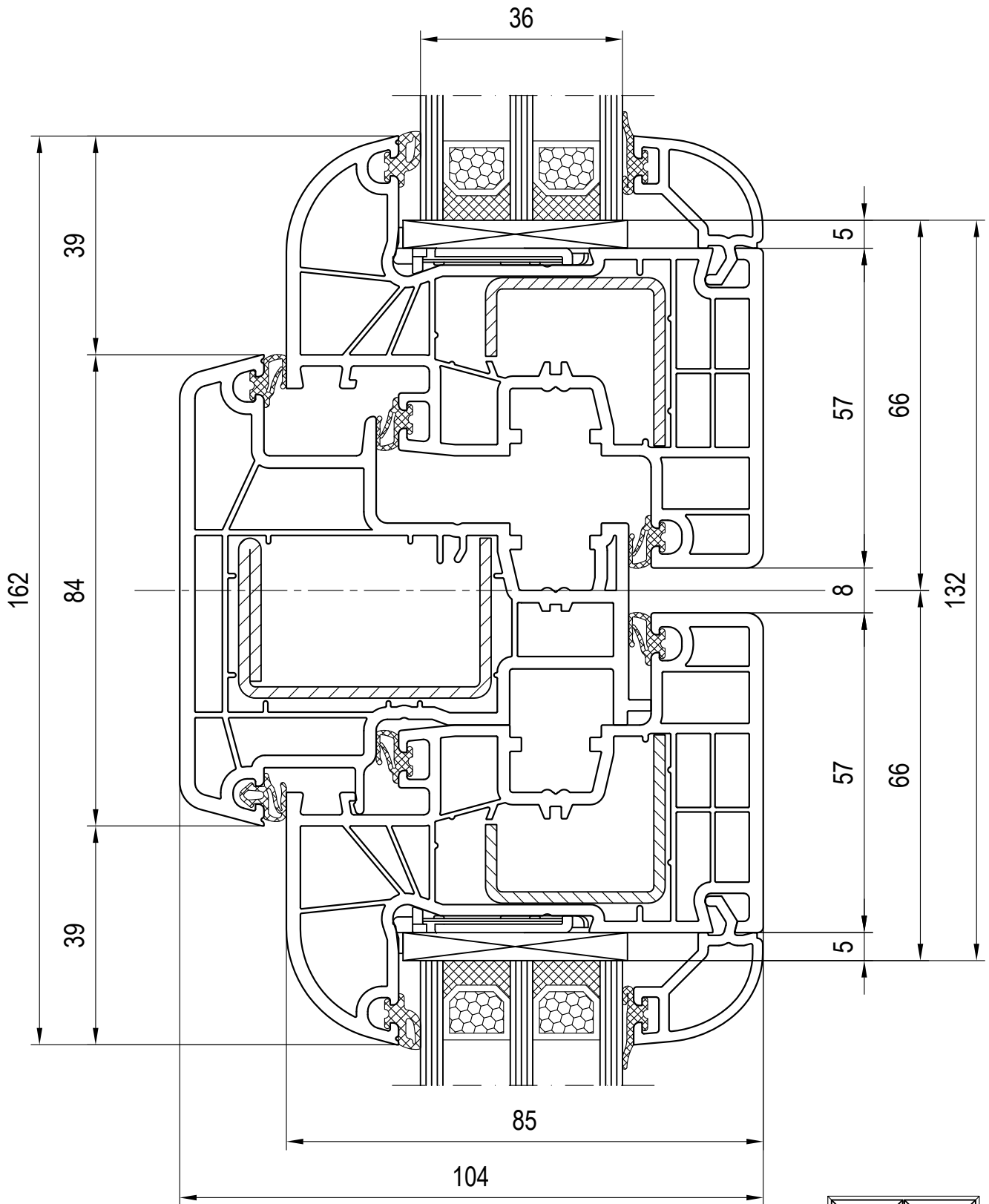

May be subject to change  
and errors excepted!  
scale: 1:1  
03\_L\_01\_8\*

Combinations: Sash - False Mullion - Sash  
Glazing Bead 120650/120680

**False Mullion 180x66**  
**Sash 180x22**

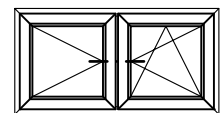
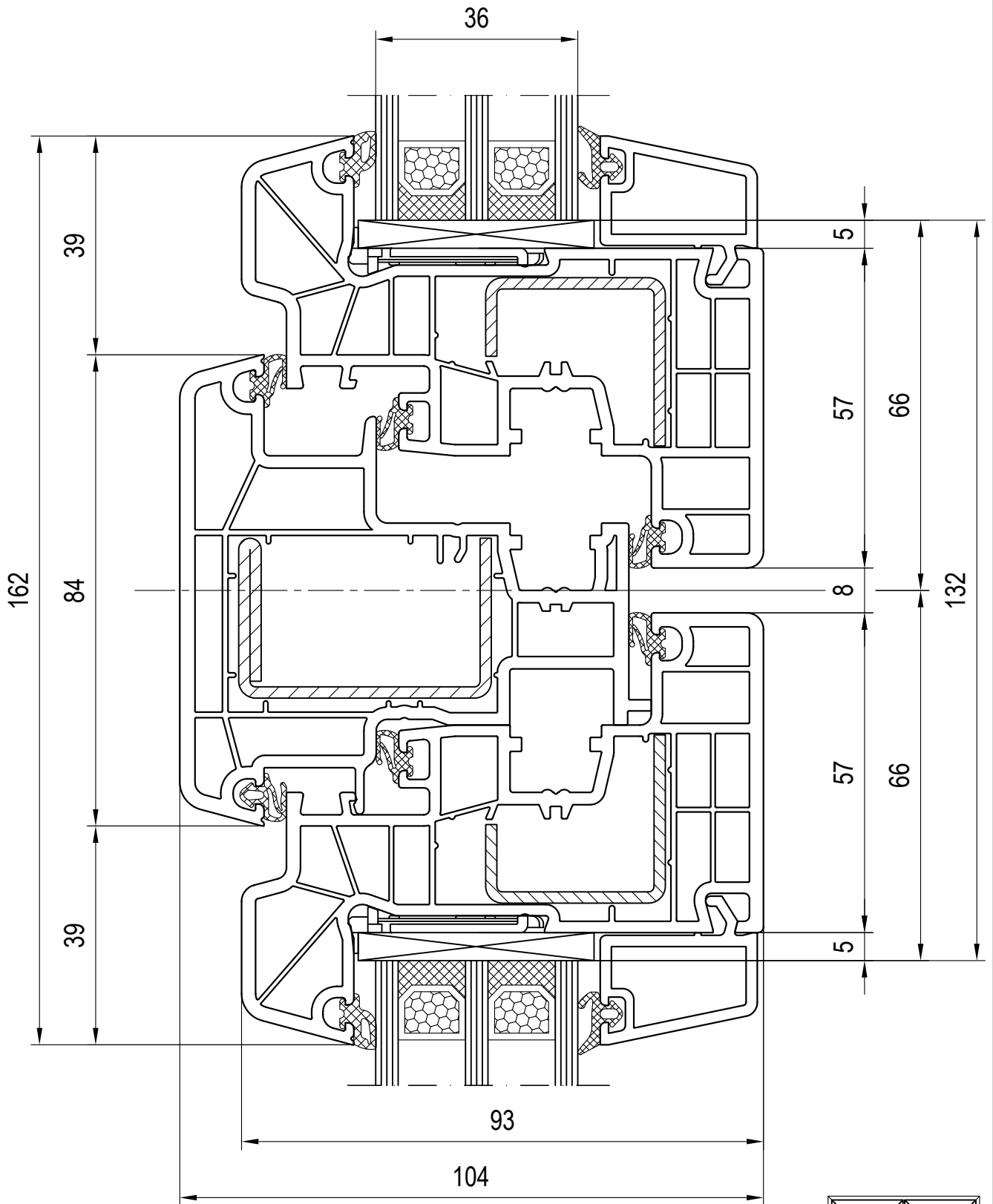

May be subject to change  
and errors excepted!  
scale: 1:1  
03\_L\_01\_8\*

Combinations: Sash - False Mullion - Sash  
Glazing Bead 120838/120868

**False Mullion 180x66**  
**Sash 180x26**

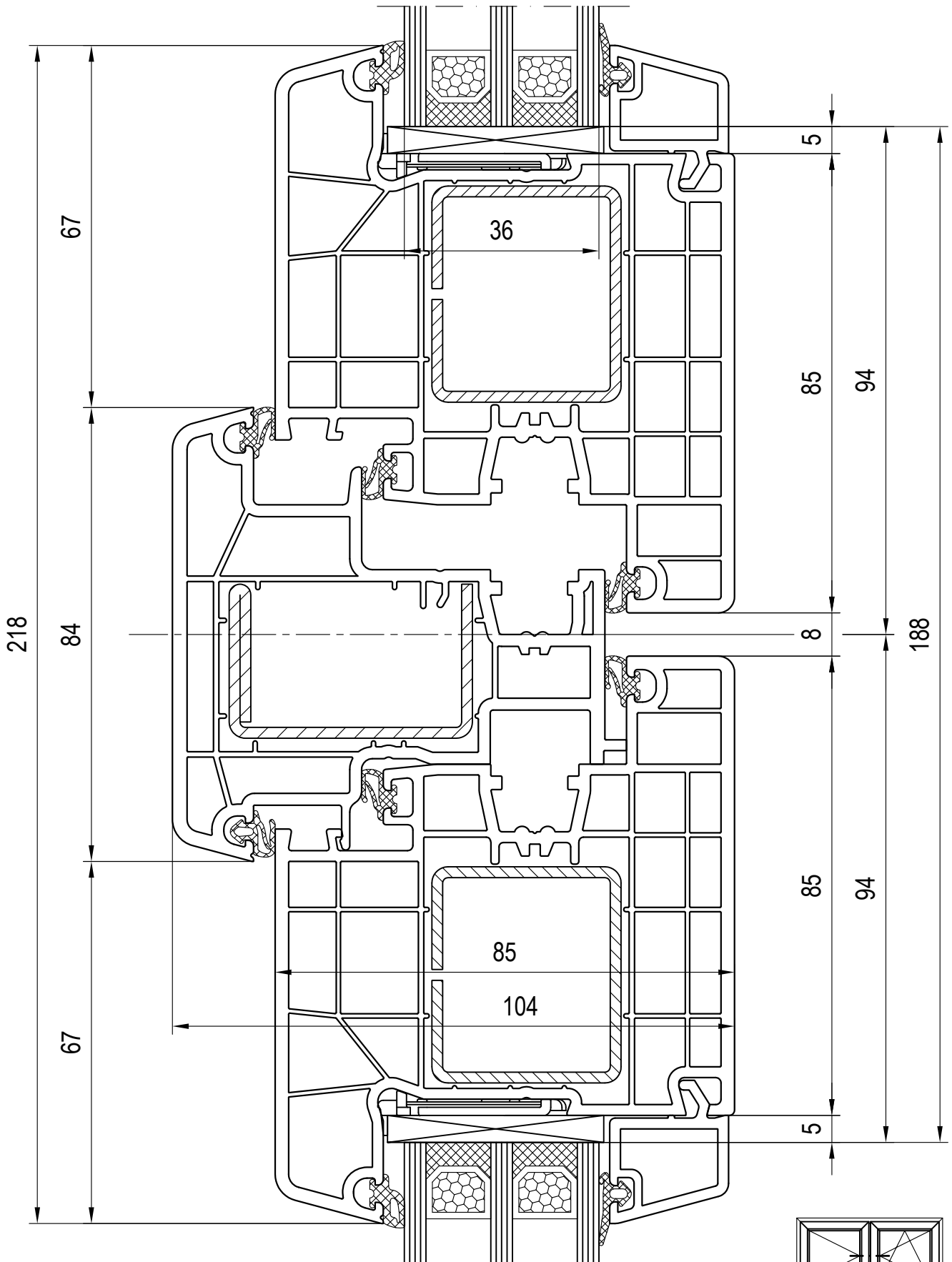

May be subject to change and errors excepted!

scale: 1:1  
03\_L\_01\_8\*

Combinations: Sash - False Mullion - Sash  
Glazing Bead 120636/120666

**False Mullion 180x66**  
**Sash 180x30**

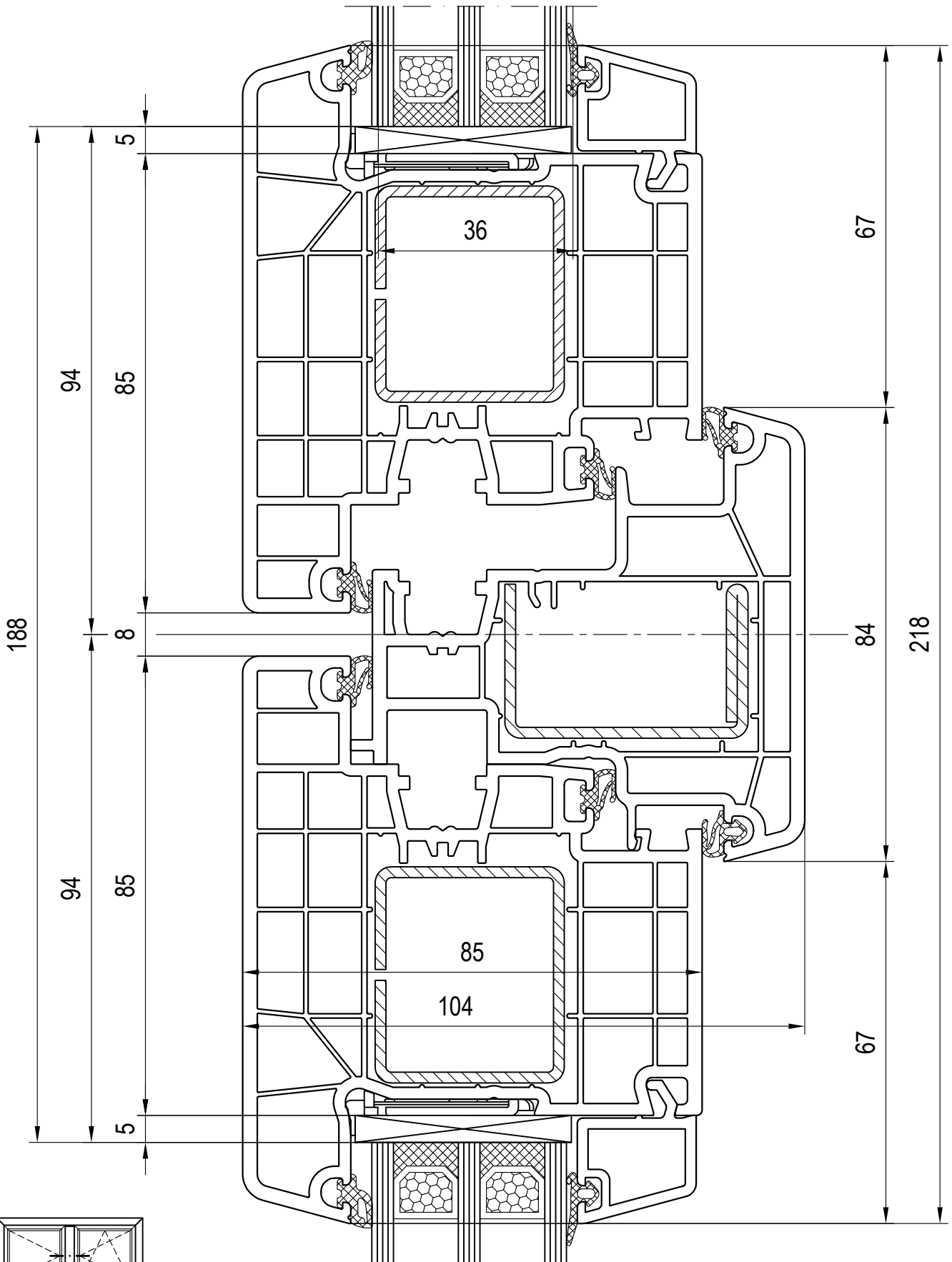

May be subject to change  
 and errors excepted!

scale: 1:1  
 03\_L\_01\_8\*

Combinations: Sash - False Mullion - Sash  
 Glazing Bead 120636/120666

False Mullion 180x66  
 Sash 180x31

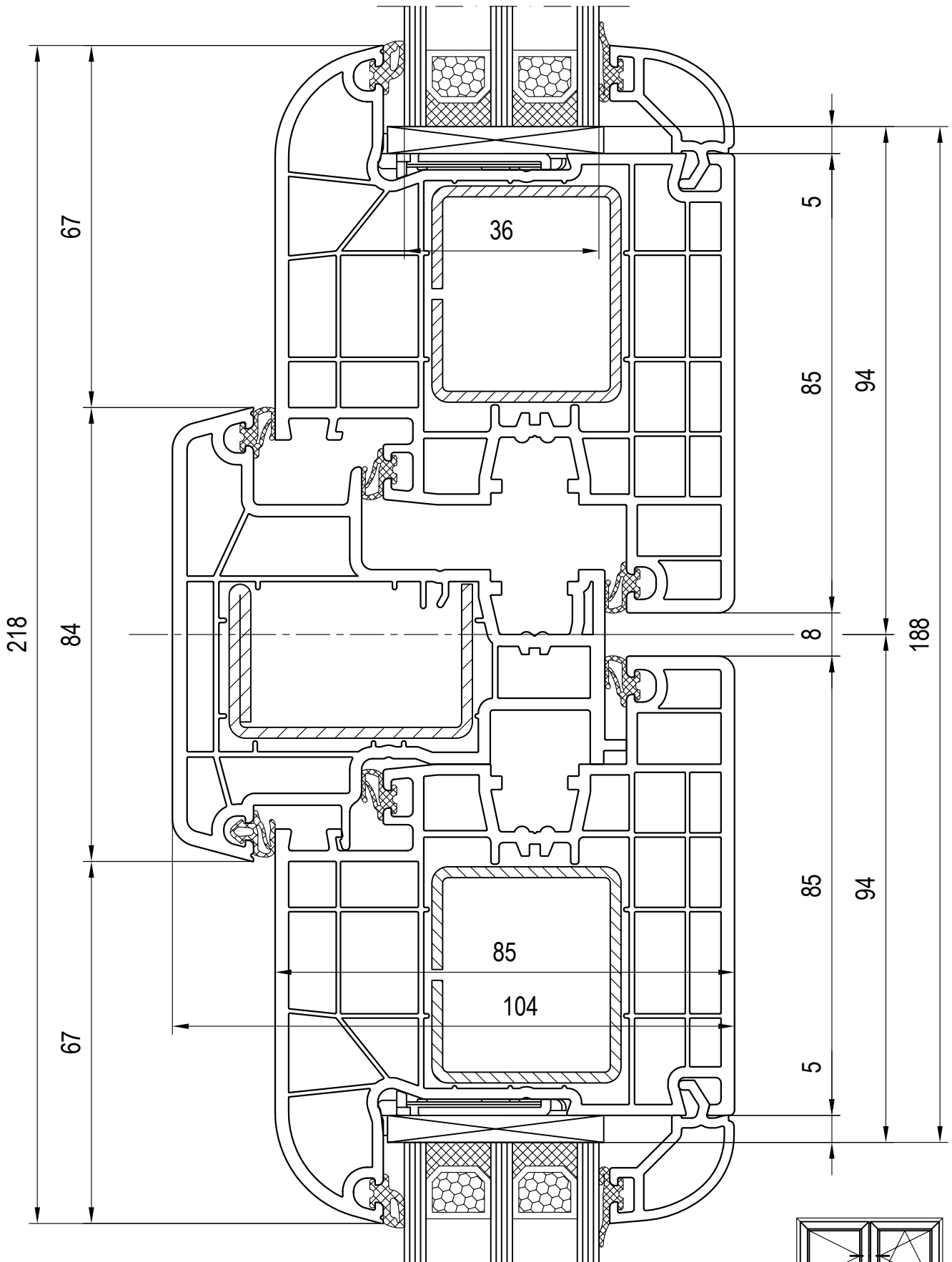

May be subject to change and errors excepted!

scale: 1:1  
03\_L\_01\_8\*

Combinations: Sash - False Mullion - Sash  
Glazing Bead 120650/120680

False Mullion 180x66  
Sash 180x32

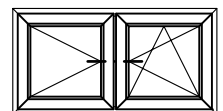
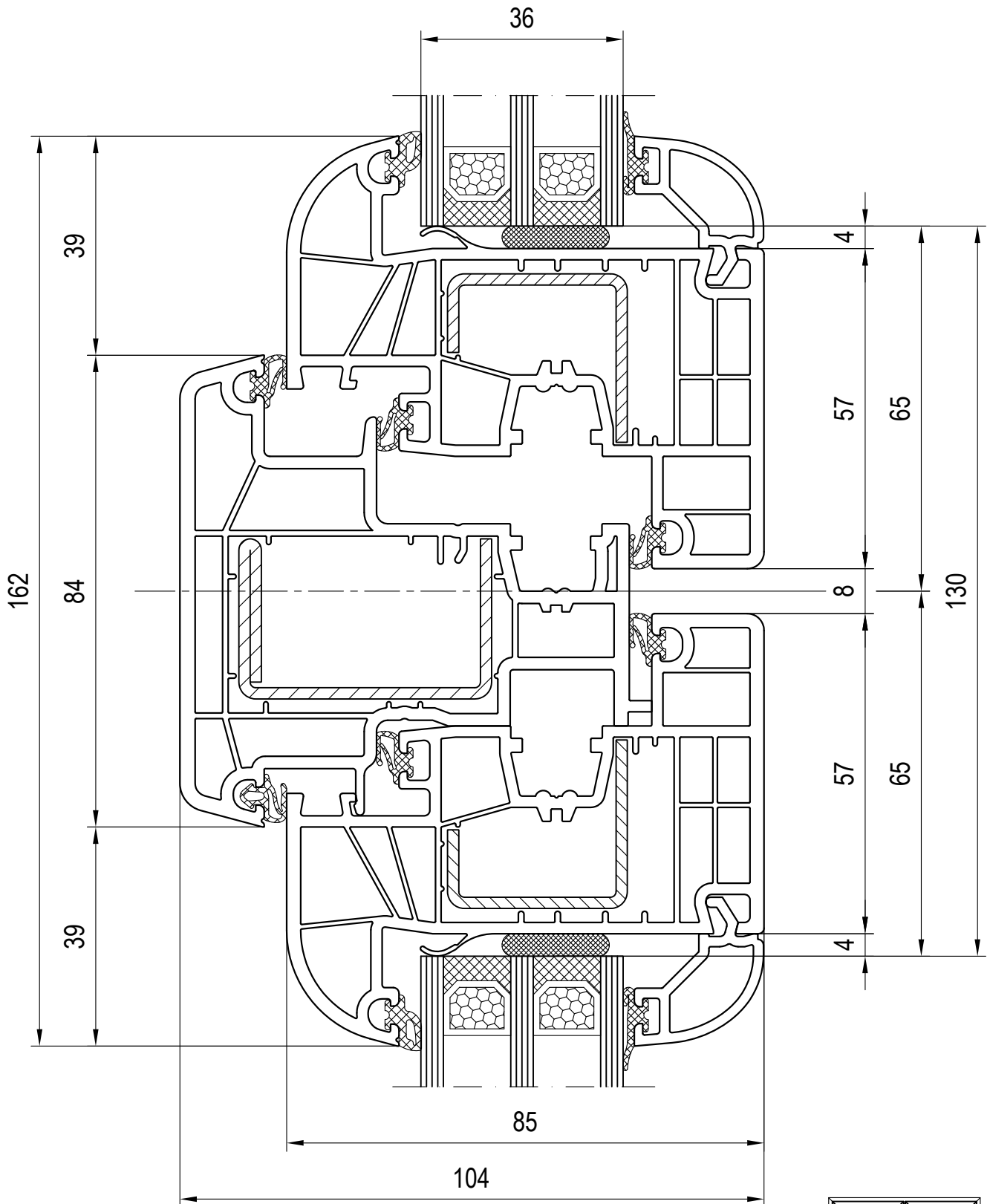

May be subject to change  
and errors excepted!

scale: 1:1  
03\_L\_01\_8\*

Combinations: Sash - False Mullion - Sash  
Glazing Bead 120650/120680

False Mullion 180x66  
Sash 180x83



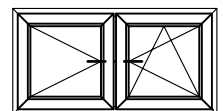
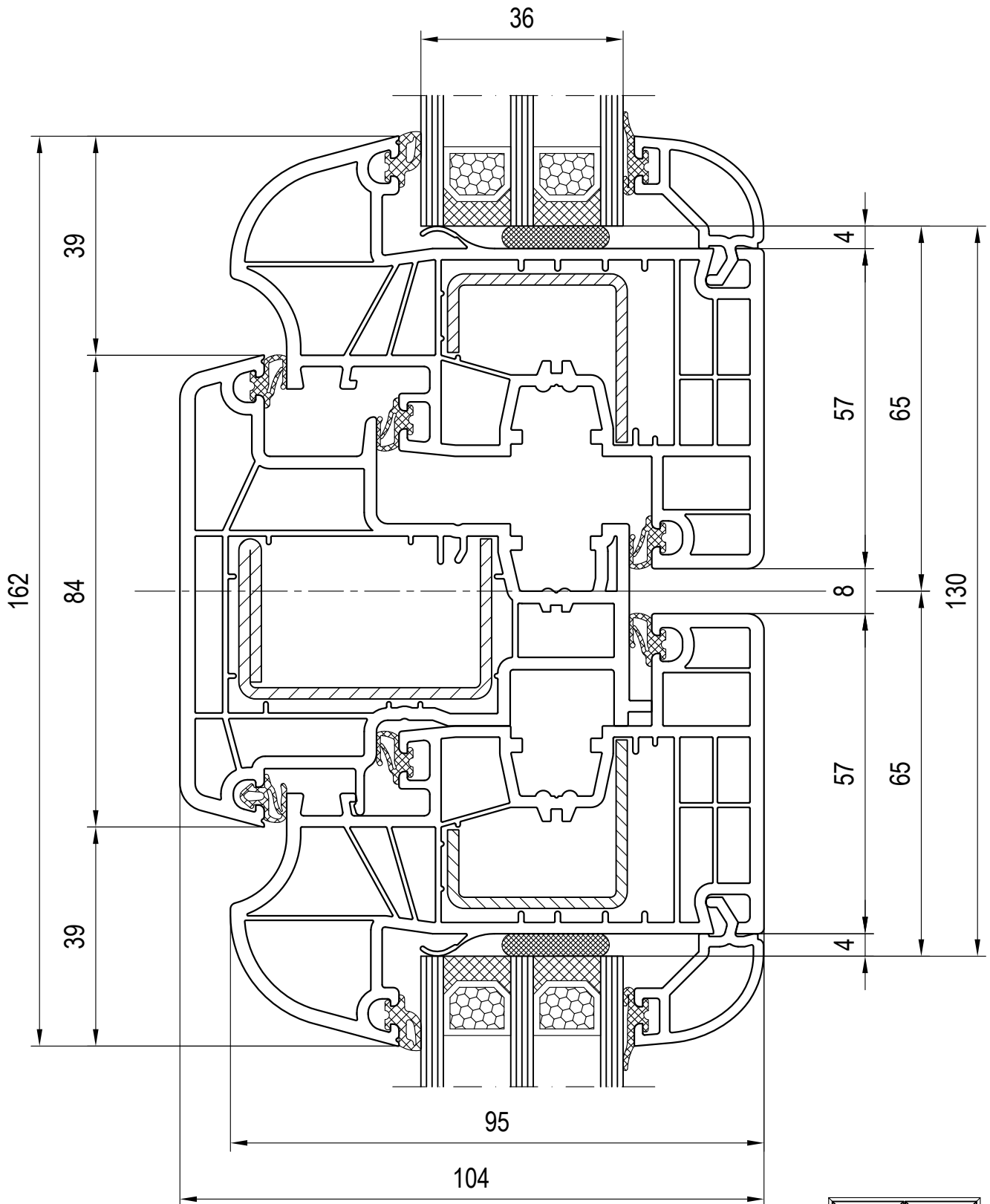

May be subject to change  
and errors excepted!

scale: 1:1  
03\_L\_01\_8\*

Combinations: Sash - False Mullion - Sash  
Glazing Bead 120650/120680

False Mullion 180x66  
Sash 180x85

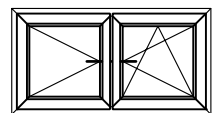
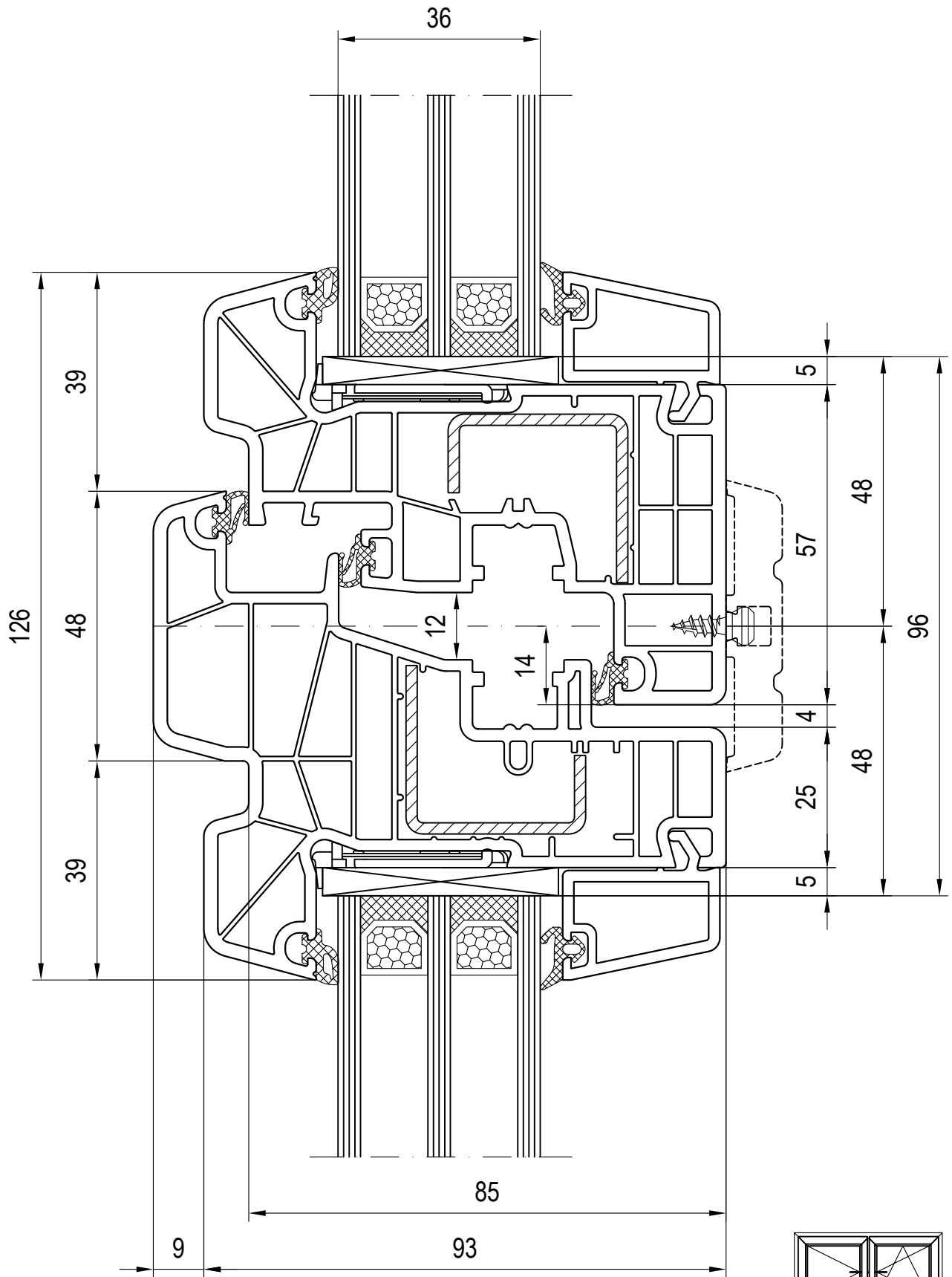

May be subject to change  
 and errors excepted!

scale: 1:1  
 03\_M\_01\_8\*

Combinations: False Mullion Sash - Sash False Mullion Sash 180x69  
 Glazing Bead 120838/120868 Sash 180x26

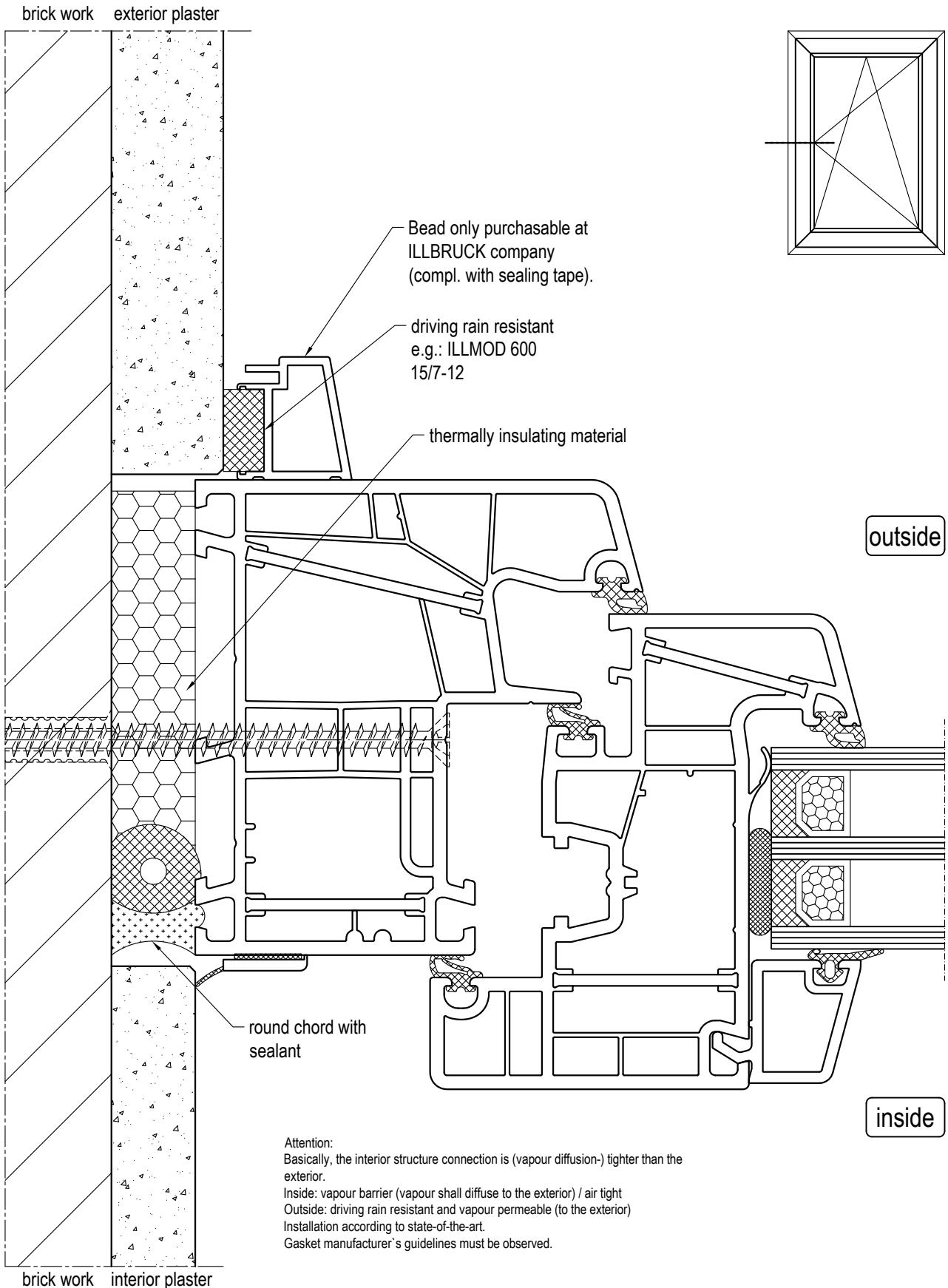

May be subject to change and errors excepted!

scale: 1:1  
03\_Z\_01\_8\*

## Examples for Structure Connection without stop

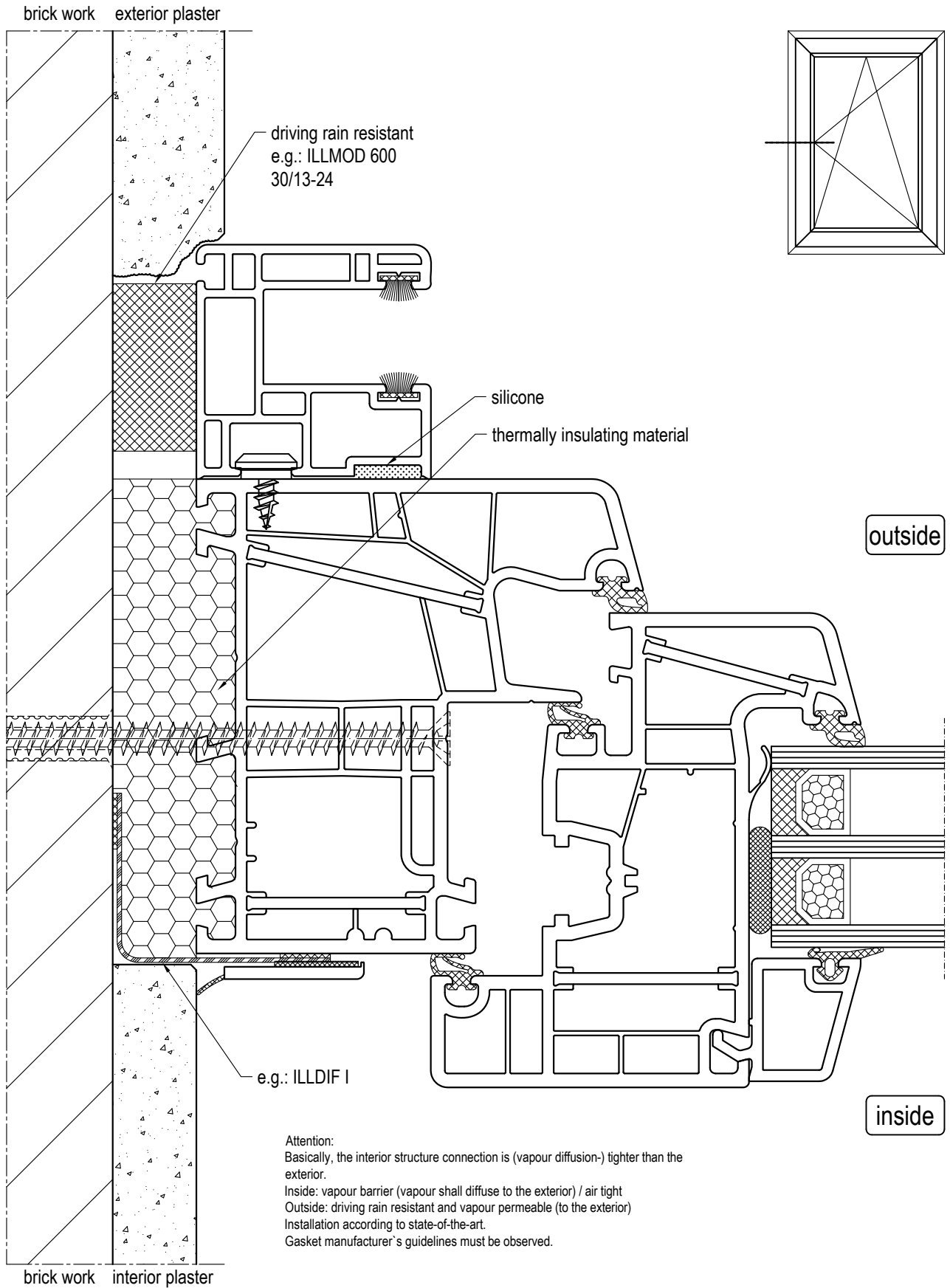

May be subject to change and errors excepted!

scale: 1:1  
03\_Z\_01\_8\*

## Examples for Structure Connection without stop

brick work exterior plaster

e.g. for renovation of concrete slab buildings

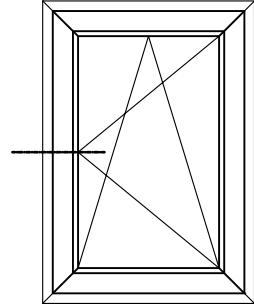

driving rain resistant  
e.g.: ILLMOD 600  
25/10-18

silicone

silicone at least on left + right side:  
see chapter 08 C 3. Extensions

outside

silicone

round chord with  
sealant

inside

Attention:  
Basically, the interior structure connection is (vapour diffusion-) tighter than the exterior.  
Inside: vapour barrier (vapour shall diffuse to the exterior) / air tight  
Outside: driving rain resistant and vapour permeable (to the exterior)  
Installation according to state-of-the-art.  
Gasket manufacturer's guidelines must be observed.

brick work

interior plaster

May be subject to change  
and errors excepted!

scale: 1:1  
03\_Z\_01\_8\*

Examples for Structure Connection  
exterior stop

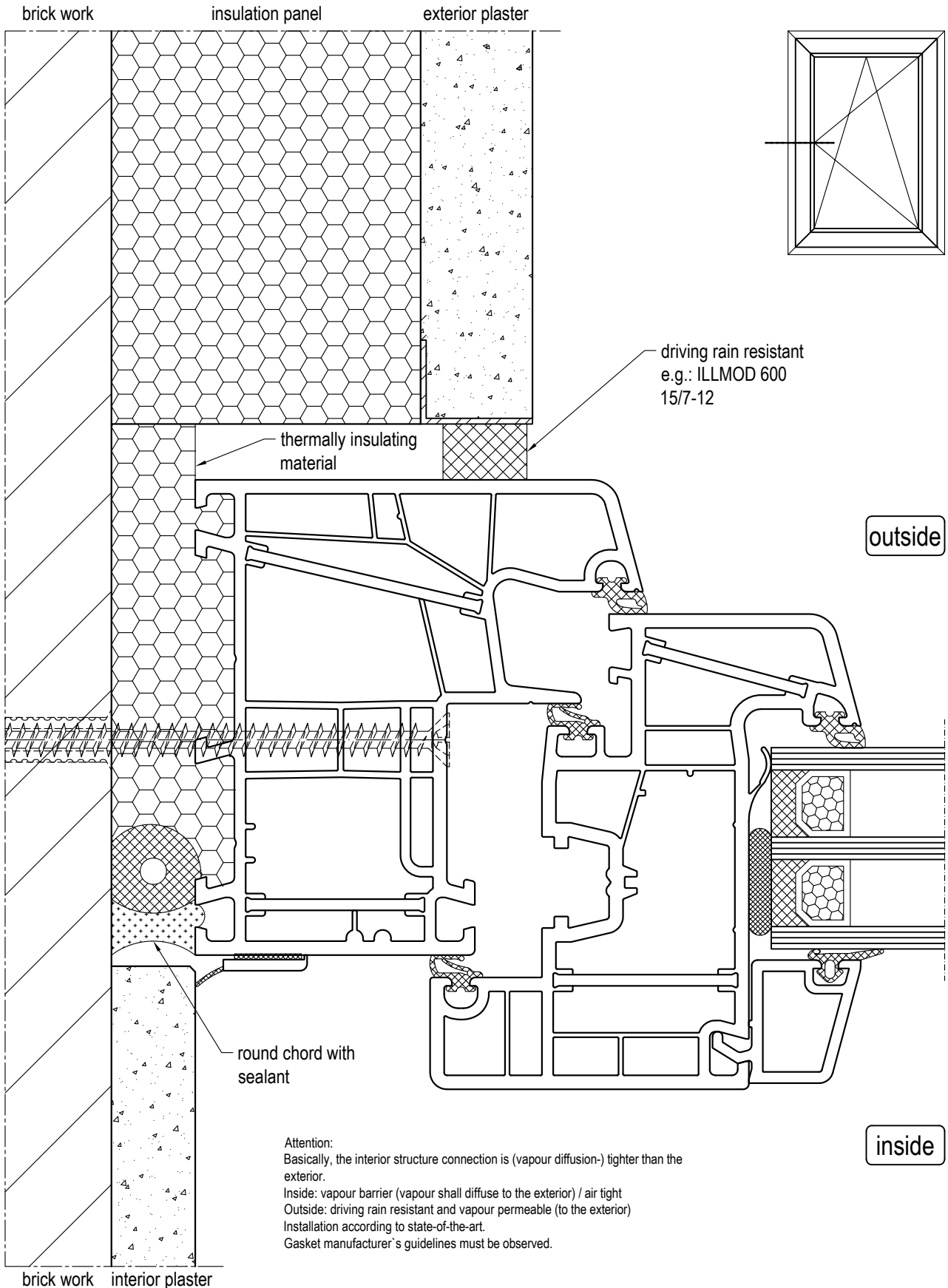

May be subject to change  
and errors excepted!

scale: 1:1  
03\_Z\_01\_8\*

Examples for Structure Connection  
interior stop

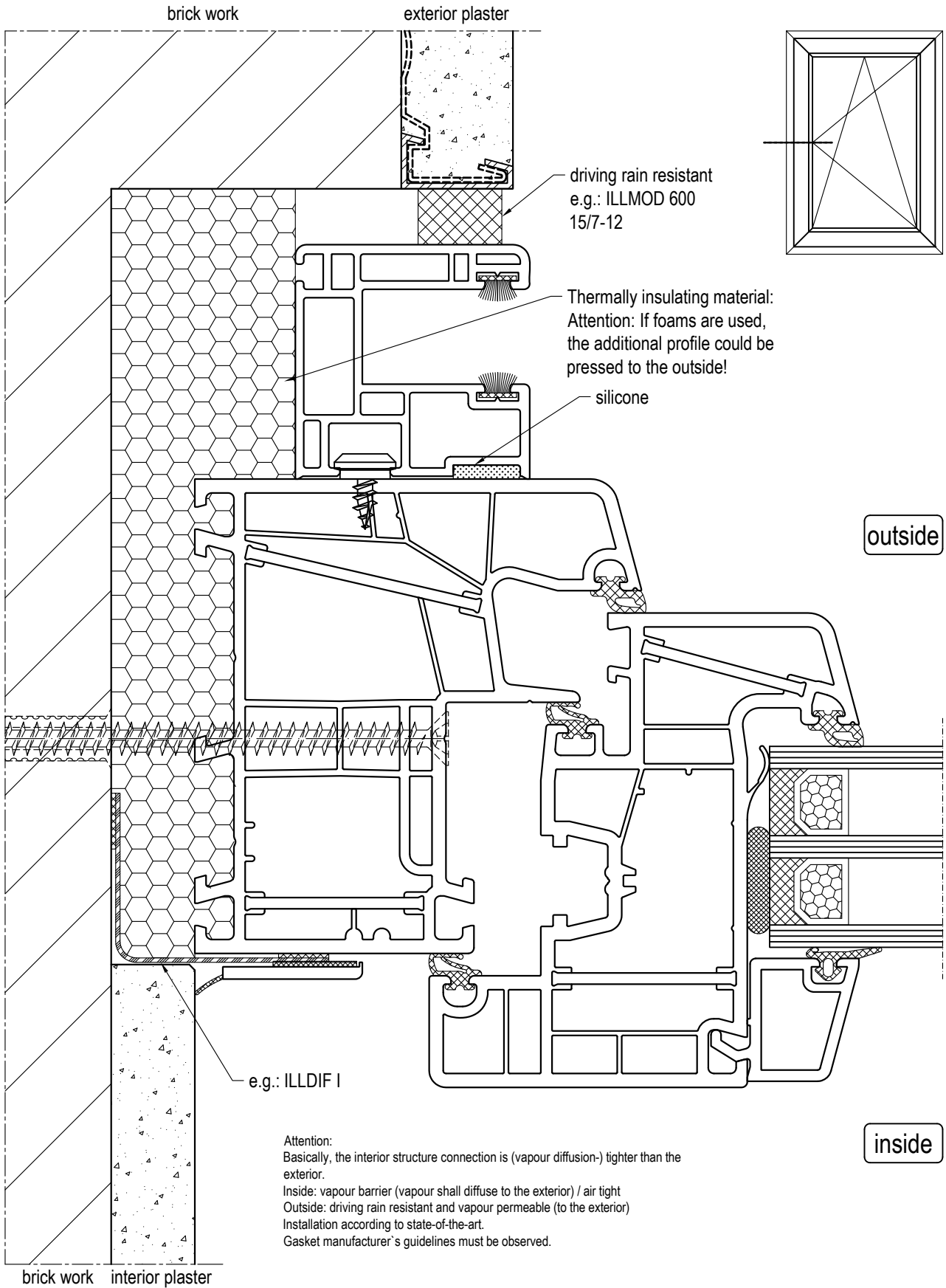

May be subject to change  
and errors excepted!

scale: 1:1  
03\_Z\_01\_8\*

Examples for Structure Connection  
interior stop

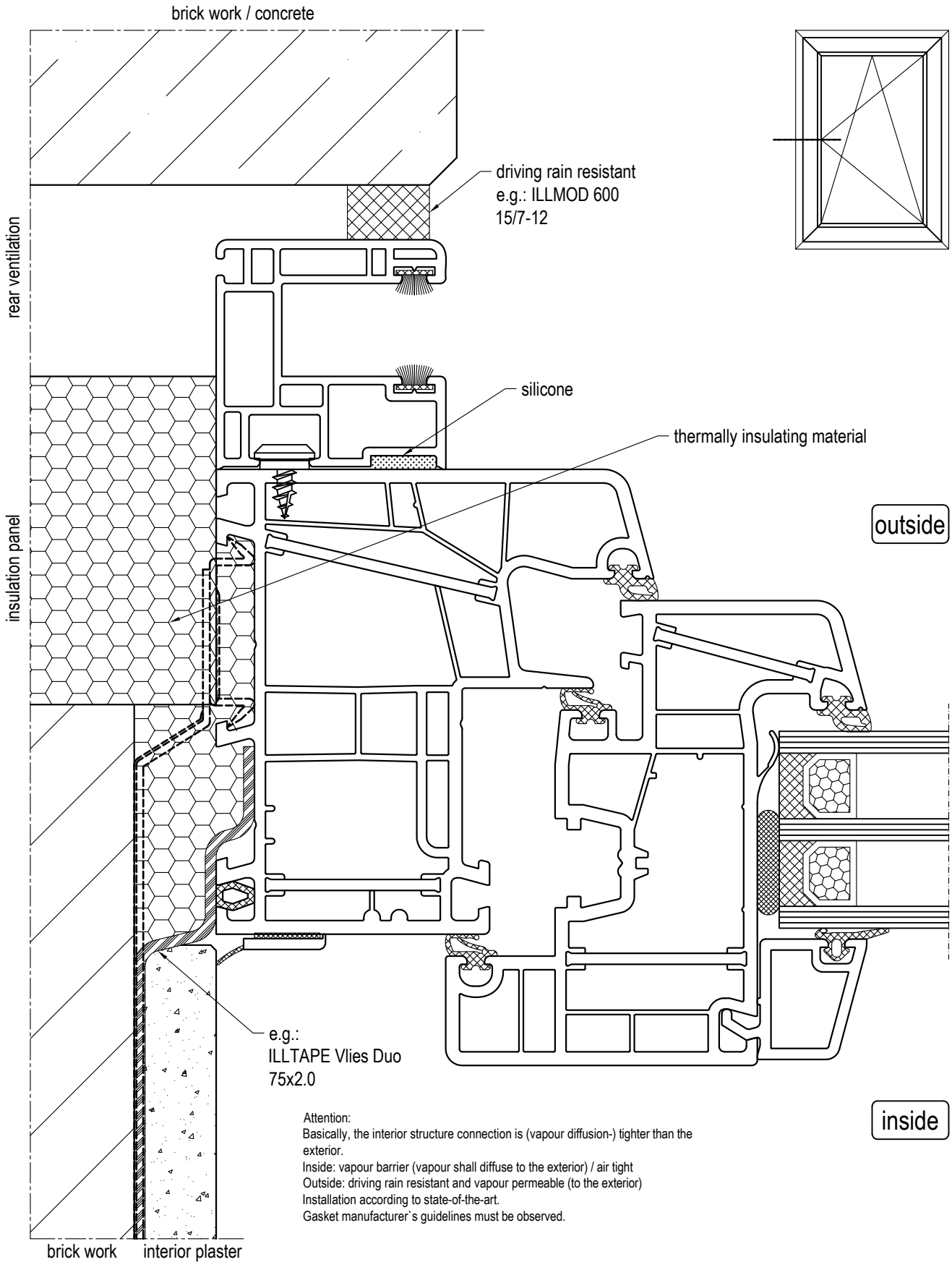

May be subject to change  
and errors excepted!

scale: 1:1  
03\_Z\_01\_8\*

Examples for Structure Connection  
interior stop



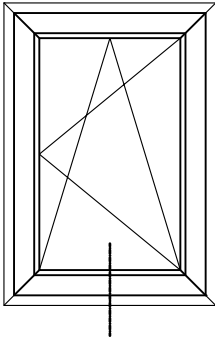

Attention:  
Basically, the interior structure connection is (vapour diffusion-) tighter than the exterior.  
Inside: vapour barrier (vapour shall diffuse to the exterior) / air tight  
Outside: driving rain resistant and vapour permeable (to the exterior)  
Installation according to state-of-the-art.  
Gasket manufacturer's guidelines must be observed.

outside

inside

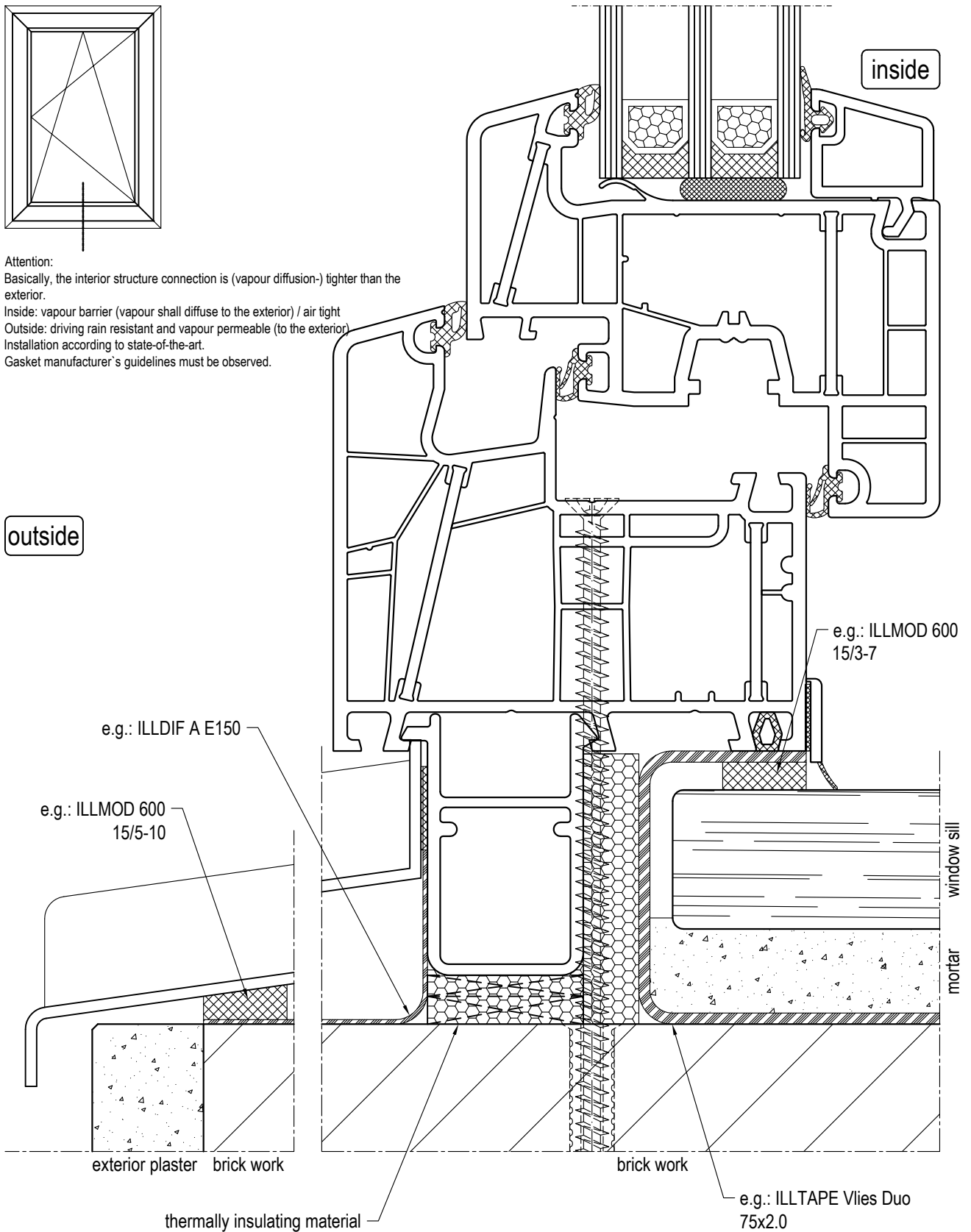

May be subject to change  
and errors excepted!

scale: 1:1  
03\_Z\_01\_8\*

## Examples for Structure Connection bottom connection

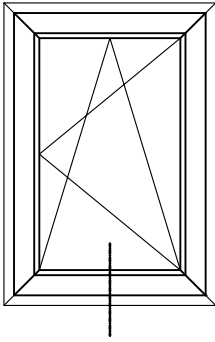

Attention:  
Basically, the interior structure connection is (vapour diffusion-) tighter than the exterior.  
Inside: vapour barrier (vapour shall diffuse to the exterior) / air tight  
Outside: driving rain resistant and vapour permeable (to the exterior)  
Installation according to state-of-the-art.  
Gasket manufacturer's guidelines must be observed.

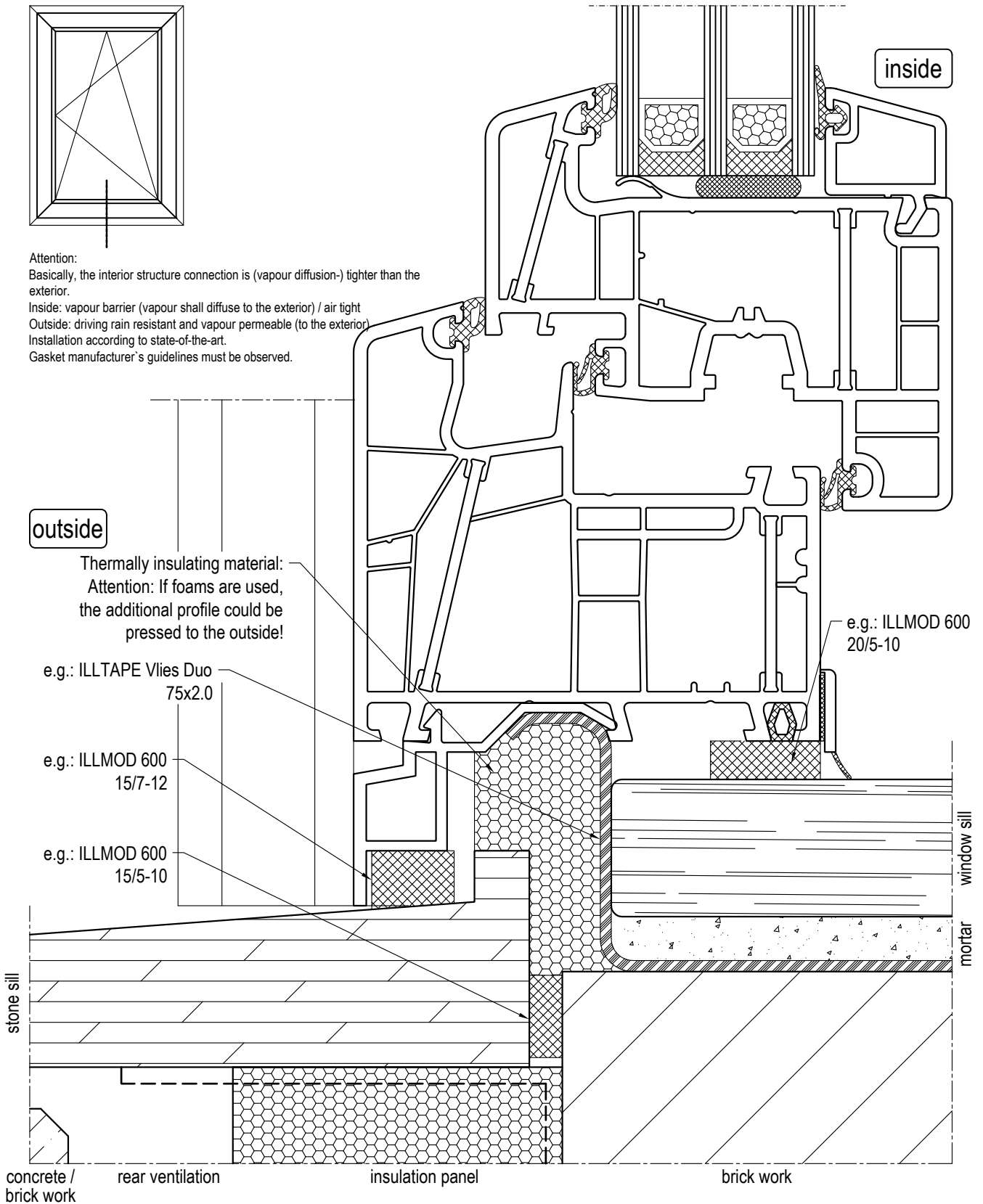

May be subject to change  
and errors excepted!

scale: 1:1  
03\_Z\_01\_8\*

Examples for Structure Connection  
bottom connection

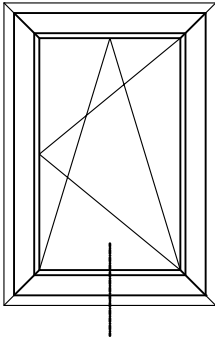

Attention:  
Basically, the interior structure connection is (vapour diffusion-) tighter than the exterior.  
Inside: vapour barrier (vapour shall diffuse to the exterior) / air tight  
Outside: driving rain resistant and vapour permeable (to the exterior)  
Installation according to state-of-the-art.  
Gasket manufacturer's guidelines must be observed.

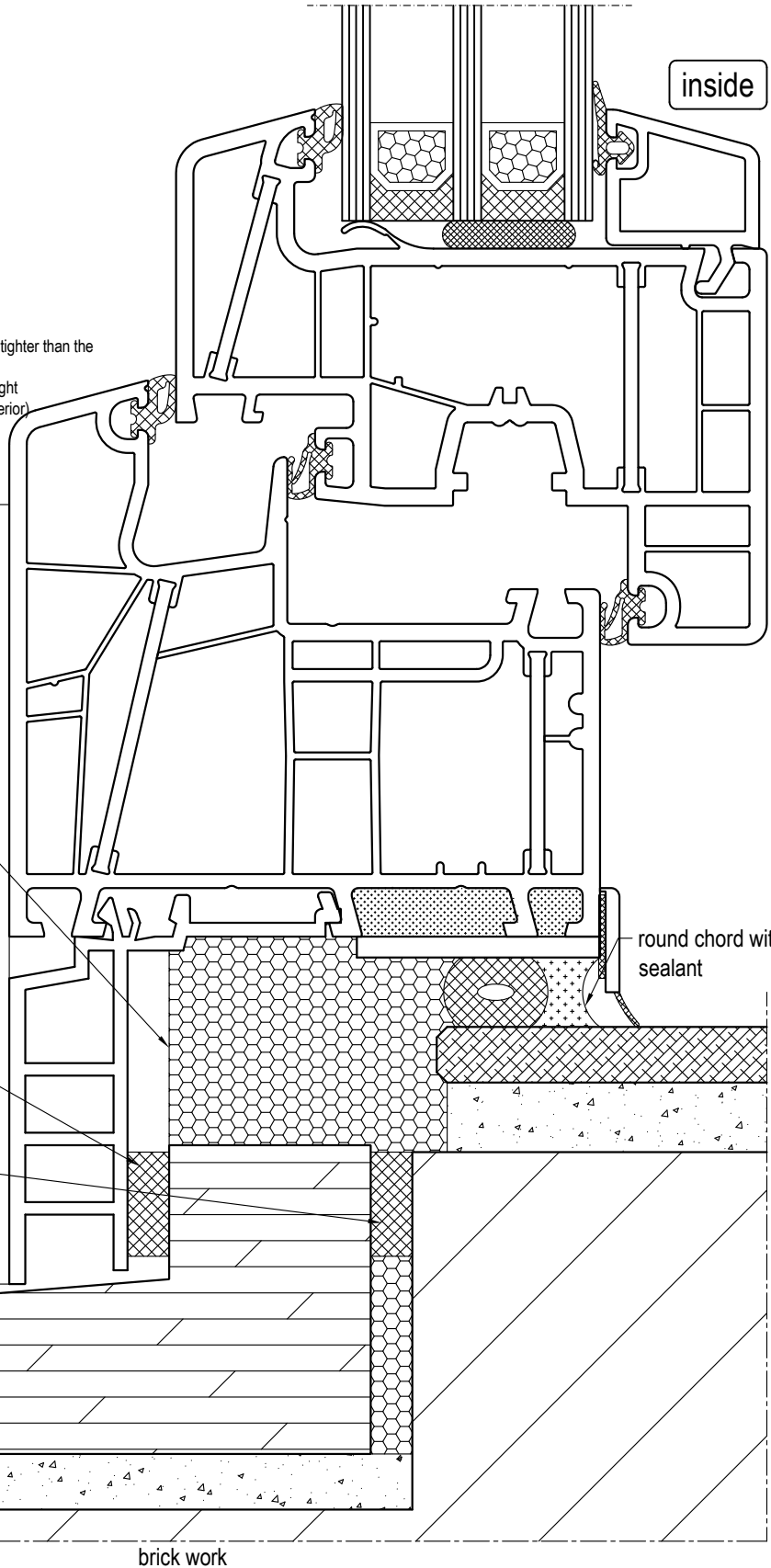

outside

Thermally insulating material:  
Attention: If foams are used,  
the additional profile could be  
pressed to the outside!

e.g.: ILLMOD 600  
15/5-10

e.g.: ILLMOD 600  
15/5-10

round chord with  
sealant

tiles  
mortar

stone sill  
mortar

brick work

May be subject to change  
and errors excepted!

scale: 1:1  
03\_Z\_01\_8\*

Examples for Structure Connection  
bottom connection

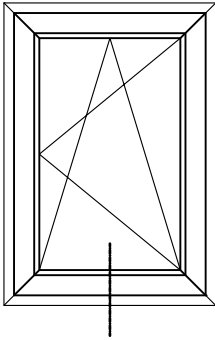

Attention:  
Basically, the interior structure connection is (vapour diffusion-) tighter than the exterior.  
Inside: vapour barrier (vapour shall diffuse to the exterior) / air tight  
Outside: driving rain resistant and vapour permeable (to the exterior)  
Installation according to state-of-the-art.  
Gasket manufacturer's guidelines must be observed.

outside

e.g.: ILLMOD 600  
20/3-7

e.g.: ILLMOD 600  
15/5-10

e.g.: ILLMOD 600  
15/7-12

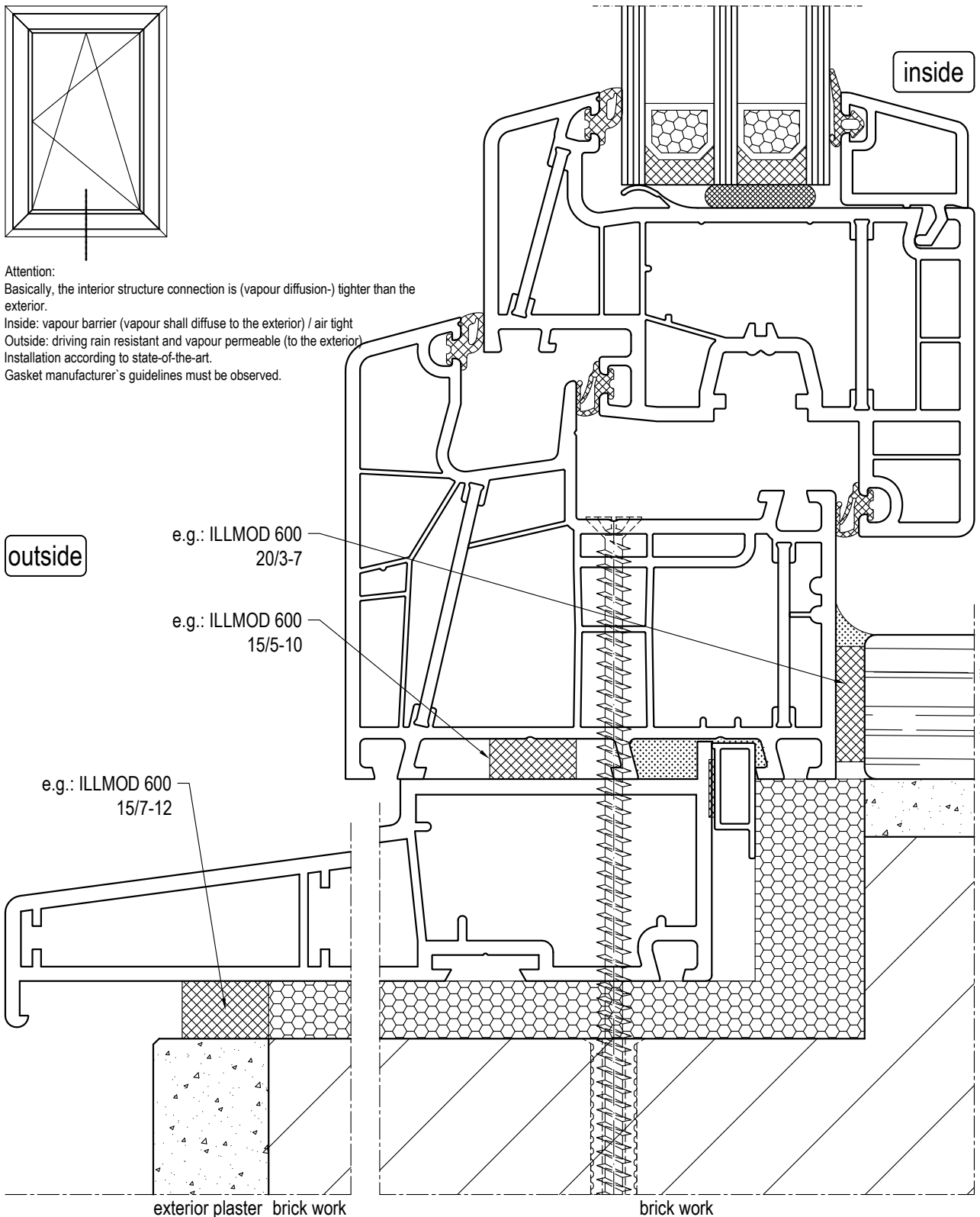

exterior plaster brick work

brick work

May be subject to change  
and errors excepted!

scale: 1:1  
03\_Z\_01\_8\*

Examples for Structure Connection  
bottom connection

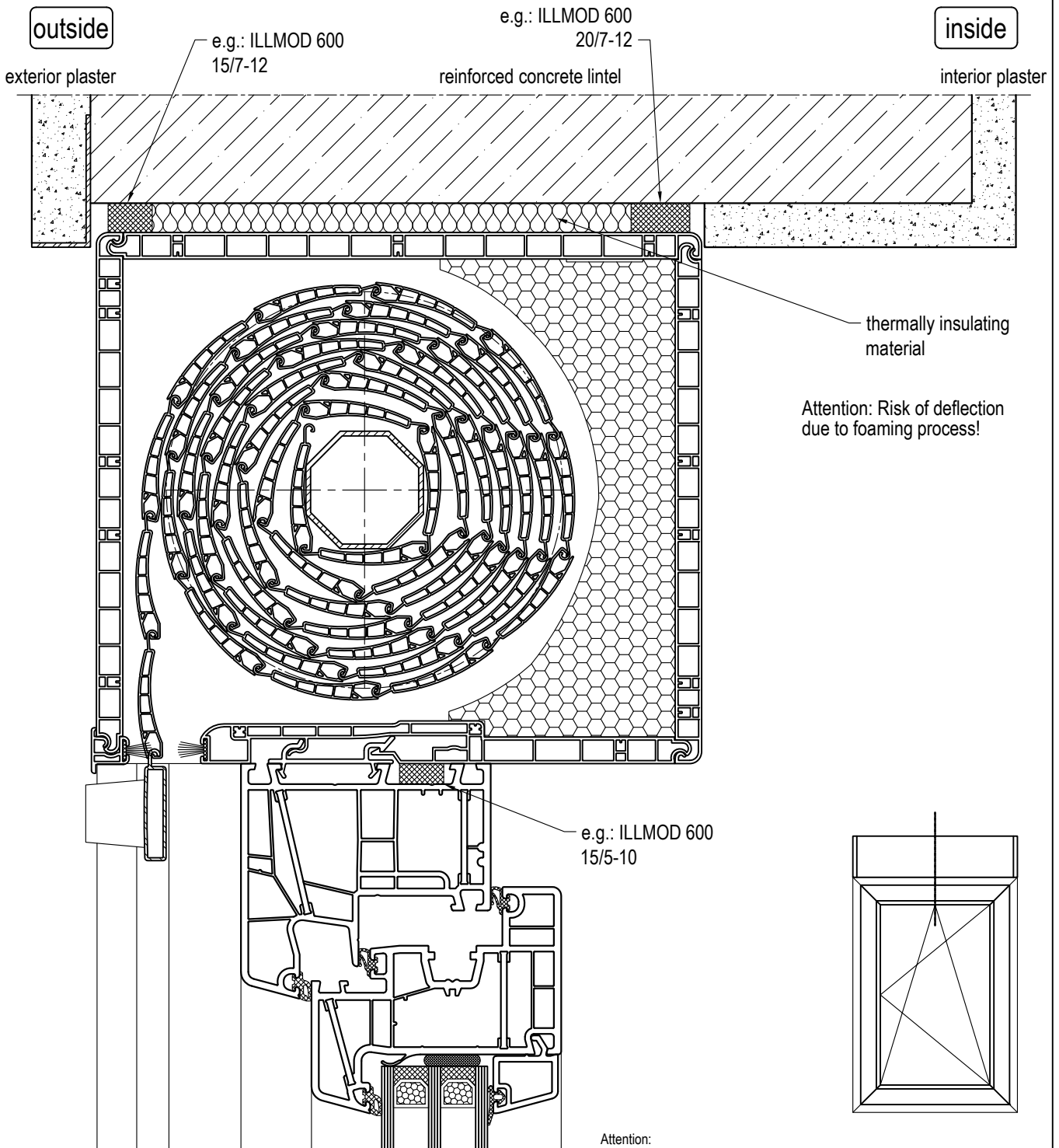

Attention:  
Basically, the interior structure connection is (vapour diffusion-) tighter than the exterior.  
Inside: vapour barrier (vapour shall diffuse to the exterior) / air tight  
Outside: driving rain resistant and vapour permeable (to the exterior)  
Installation according to state-of-the-art.  
Gasket manufacturer's guidelines must be observed.

May be subject to change and errors excepted!

scale: 1:2  
03\_Z\_01\_8\*

## Examples for Structure Connection connection at top with built-in roller shutter box

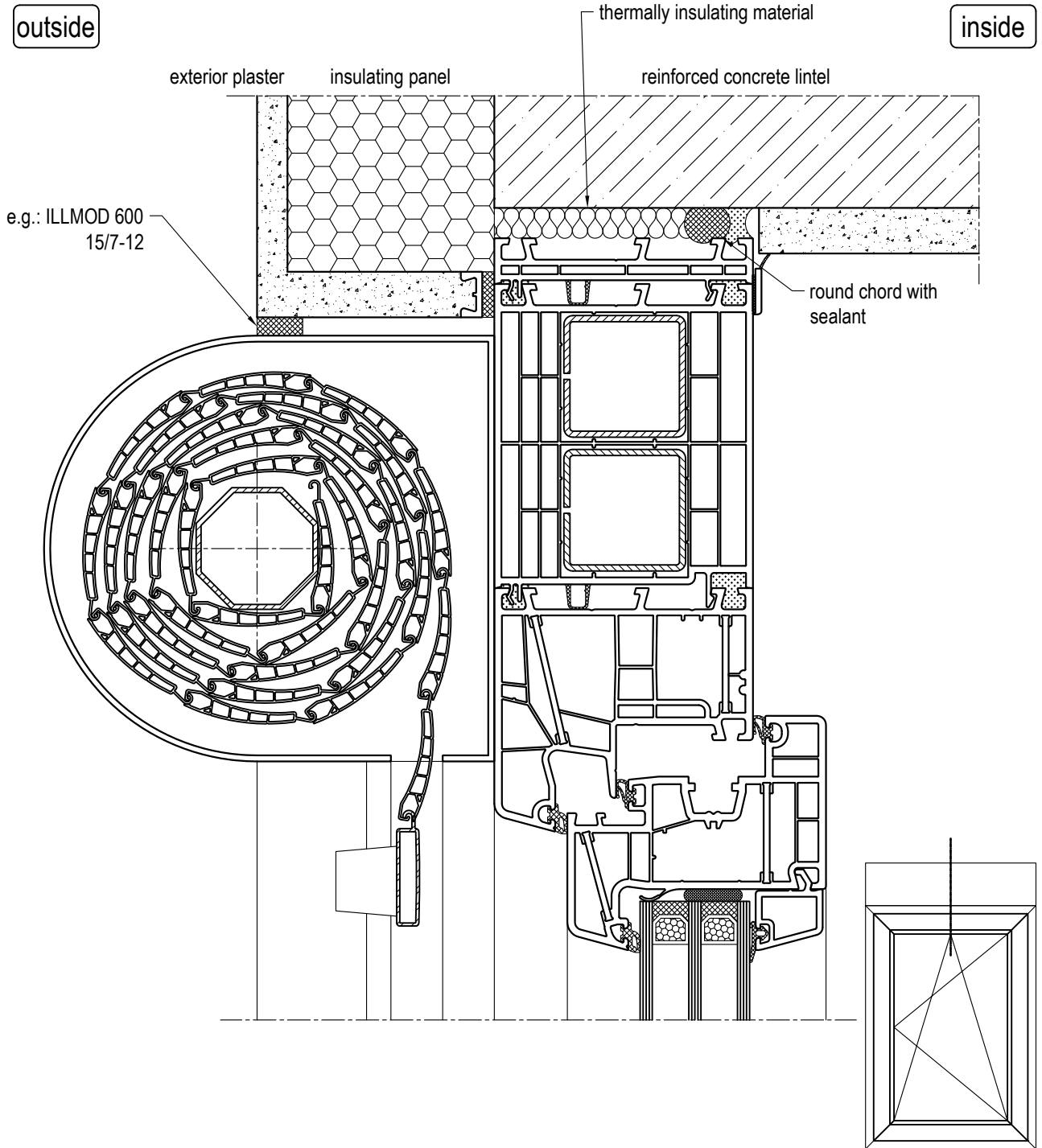

Attention:  
Basically, the interior structure connection is (vapour diffusion-) tighter than the exterior.  
Inside: vapour barrier (vapour shall diffuse to the exterior) / air tight  
Outside: driving rain resistant and vapour permeable (to the exterior)  
Installation according to state-of-the-art.  
Gasket manufacturer's guidelines must be observed.

May be subject to change and errors excepted!

scale: 1:2  
03\_Z\_01\_8\*

## Examples for Structure Connection connection at top with built-on roller shutter box

## 09 H Mechanical Connections

- Note:**
1. Choose mullion/transom with the compatible connector and the corresponding drilling jig in chapter 02 D (Main Profiles).  
(e.g. mullion 180x44 with cross connector 657034)
  2. Choose page under "Handling and Installation with required connector" in chapter 09 H (Mechanical Connections).  
(e.g. page 09 for connector 657034)

Table of Content		page
<b>General Information</b>		01 - 03
<b>Milling Patterns</b>		
mullion on frame / mullion		04
transom on sash / transom		05
<b>Description and Allocation of Drill Holes</b>		
<b>DRILLING JIG</b>	<b>DRILLING PATTERN</b>	
680900	pattern for mullion	for connector: for: 657130 / 657030, 657134 / 657034
-	pattern for transom	for: 685145
<b>Handling and Installation with</b>		
<b>DRILLING JIG</b>	<b>CONNECTOR</b>	
680900	657130 / 657030	for mullion: mullion connector
680900	657134 / 657034	for: 180x43, 180x44 cross connector
<b>Handling and Installation with</b>		
<b>DRILLING JIG</b>	<b>CONNECTOR</b>	
-	685145	for transom: transom connector
<b>Upon request</b>		
<b>(at Engineering Application Department):</b>		for: 180x46, 180x47 transom connector

Profiles with centre gasket strip  
e.g.: frame

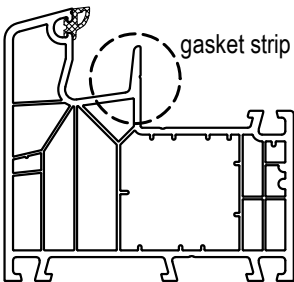

Profiles with centre gasket strip  
e.g.: mullion

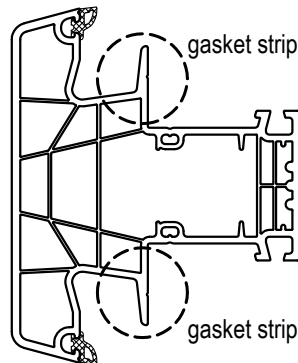

Profiles without strip:  
e.g.: sash

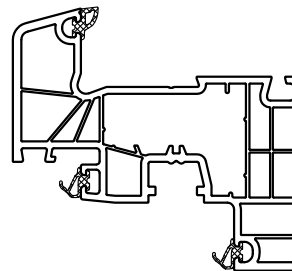

Profiles without strip:  
e.g.: transom

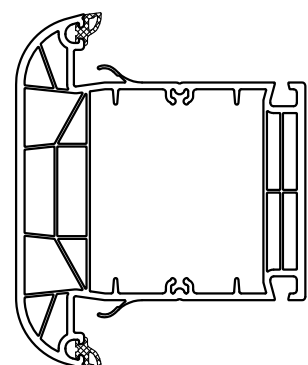
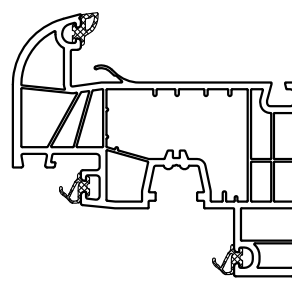
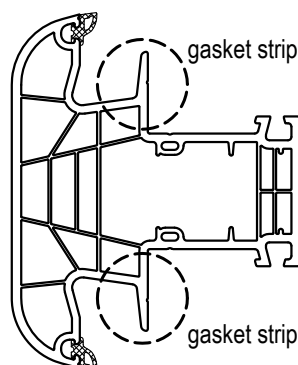
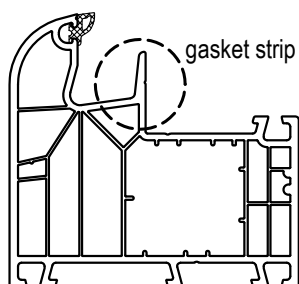
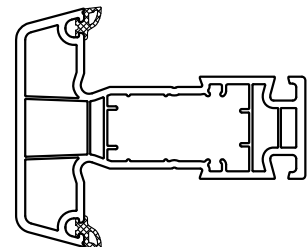

-> mullions

-> mullions

-> transoms

-> transoms

May be subject to change  
and errors excepted!

scale: ~  
09\_H\_01\_8\*

Individual Handling: Mechanical Connections  
General Information

## 09 H 1 Mechanical Mullion and Transom Connections

Contour-mill and screw (if they are not welded) mullion and transom profiles to the frame/sash or mullion/transom using special zinc die-cast connectors.

**Note:**

For any connection all screws must be inserted as described in the installation drawing.

The installation drawings in **chapter 09 H Mechanical Connections** apply.

## 09 H 2 Cleaning and Maintenance after Installation

See **chapter 10 R Cleaning, 10 S Maintenance, 10 T Ventilation**

Soiling usually occurs during the window manufacturing, for example when installing the hardware (grease) or due to ancillary marks (do not use felt markers as they often leave persistent stains and thus are not recommended here). uPVC-window profiles can be cleaned easily using water and commercially-available mild cleansing agents (e.g. washing-up liquid, curd soap, soft soap). Solvents or abrasive cleansing agents must not be used.

We recommend the **aluplast**-cleansing agent for plastic windows, **product no. 699919** (for laminated profiles **699920**).

The cleansing agent has been developed especially for surfaces of white colour or wood texture design, it keeps the recently cleaned profiles or windows clean for a considerably longer time. The cleansing agent is only suitable for profile surfaces and should not be applied on other surfaces.

Shake the bottle well before using the cleansing agent. Apply the cleansing agent with a clean, dry cloth. Stubborn soiling can be removed under a soft pressure. Wipe the profile surfaces with a damp cloth.

Laminated profiles with wood texture design are stable to corrosive agents as hard plaster, chlorinated lime and cement. They must not be treated with alcohol, nitrocellulose lacquer, lacquer diluents and organic solvents.

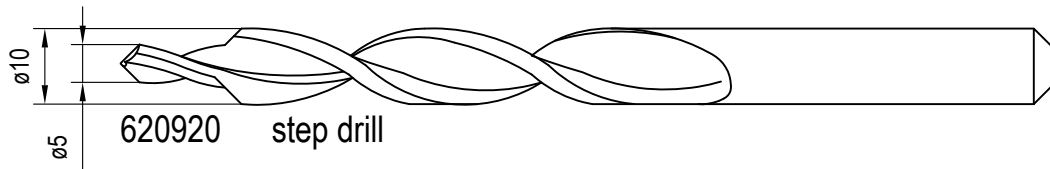

Drilling jigs with ø10mm-drill holes must be used with the step drill 620920 to get a blind hole of ø10mm in the plastic profile and a drill hole of ø5mm in the steel. (See next page)

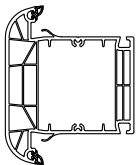
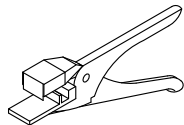
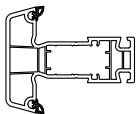
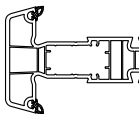
Examples for profiles with gaskets inserted in factory			gasket scissors
transom 180x45		transom 180x46	 640940
		transom 180x47	
			

x = colour code (profiles with gasket) / see current price list



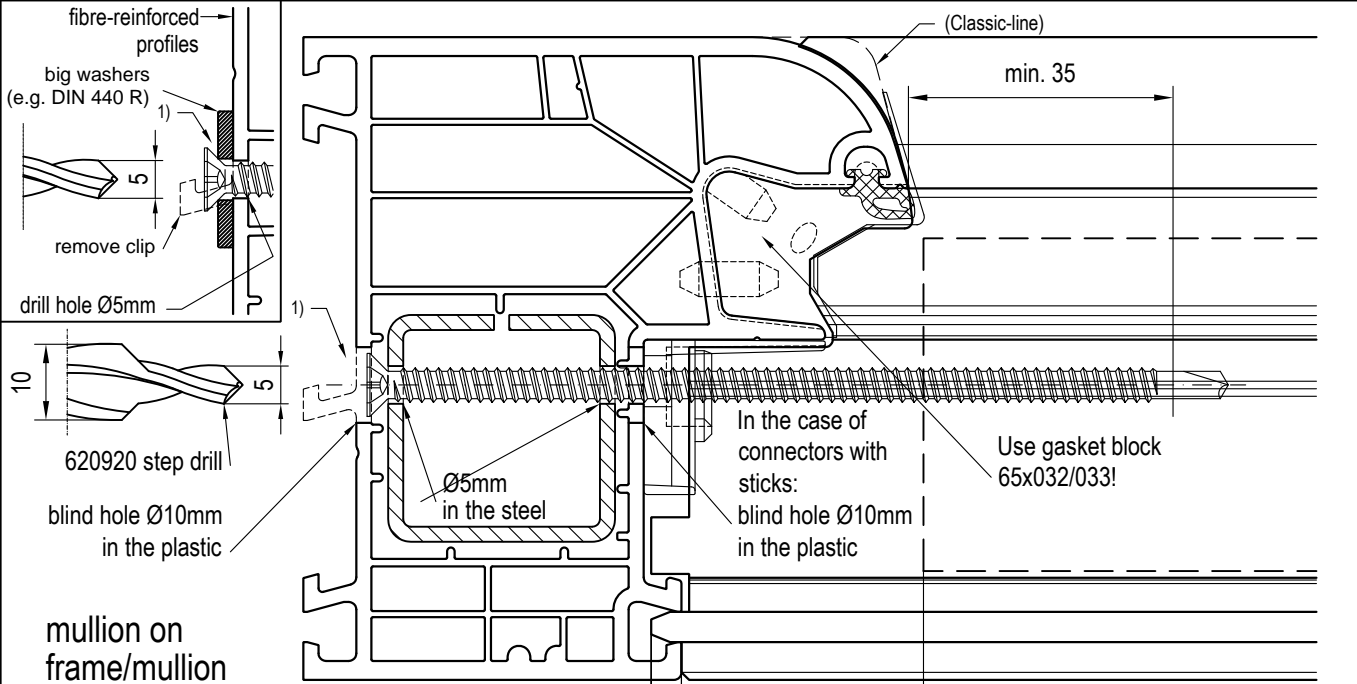

## mullion on frame/mullion

The screw connection must project approx. 35mm beyond the profile edge. Drill a hole of Ø5mm into reinforcement.

- In the case of reinforced frames and mullions, it is recommended to drill a blind hole of Ø10mm (depends on screw head or in the case of connectors with stick).
- In the case of fibre-reinforced profiles (powerdur inside) drill a hole of Ø5mm into the profile, for connectors with sticks drill a blind hole of Ø10mm into the rebate. Use a big washer (e.g. shape R = round hole mainly for wood constructions according to DIN 440 R). Fasten only hand-tight! Deformation of fibre-reinforced profiles due to increased application of a force during fastening must not occur. (See manual General Handling Directions, chapter 08 P Fibre-reinforced profiles - powerdur inside.)

<sup>1)</sup> Seal all drill holes (or open screws / washers) after screwing!

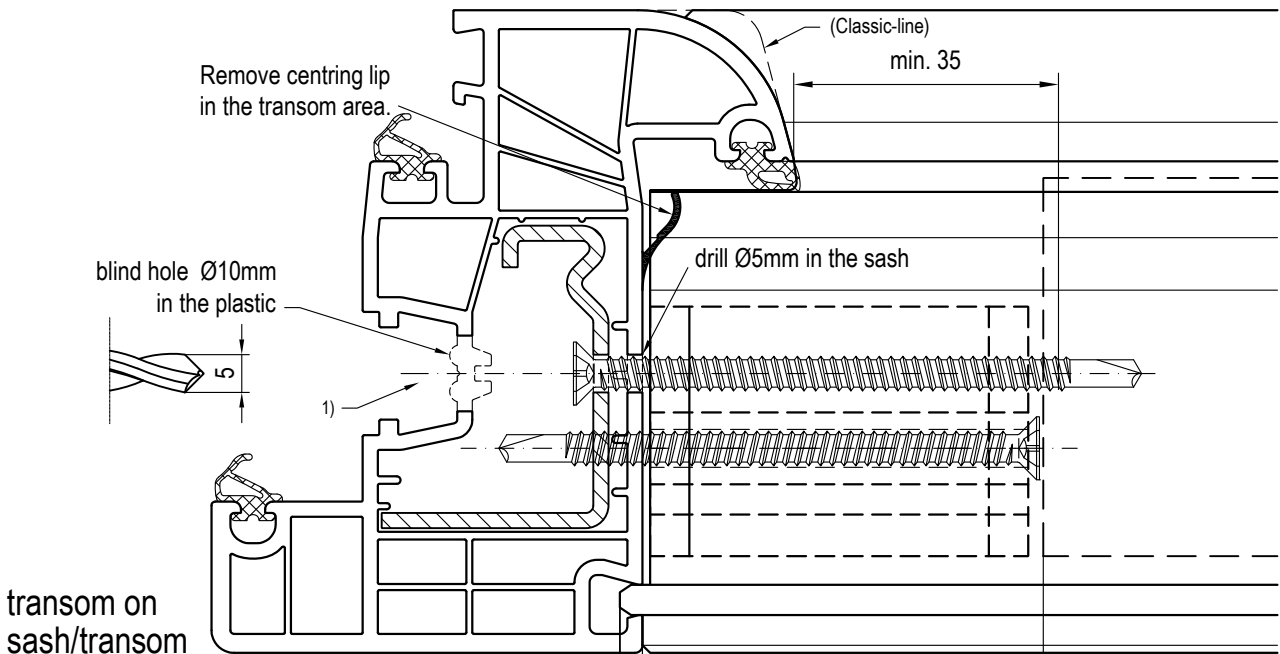

## transom on sash/transom

The screw connection must project approx. 35mm beyond the profile edge. Example with sash for bonding of pane without reinforcement.

- For sashes and transoms with reinforcement, it is recommended to drill a blind hole of Ø10mm (depends on screw head or in the case of connectors with sticks) and to drill a hole of Ø5mm in the steel (compare with drilling in the frame / see above).

May be subject to change and errors excepted!

scale: 1:1  
09\_H\_01\_8\*

Individual Handling: Mechanical Connections  
General Information

## MILLING PATTERN 1.1.

for mullion on:  
Round-line profiles:  
- frame  
- mullion

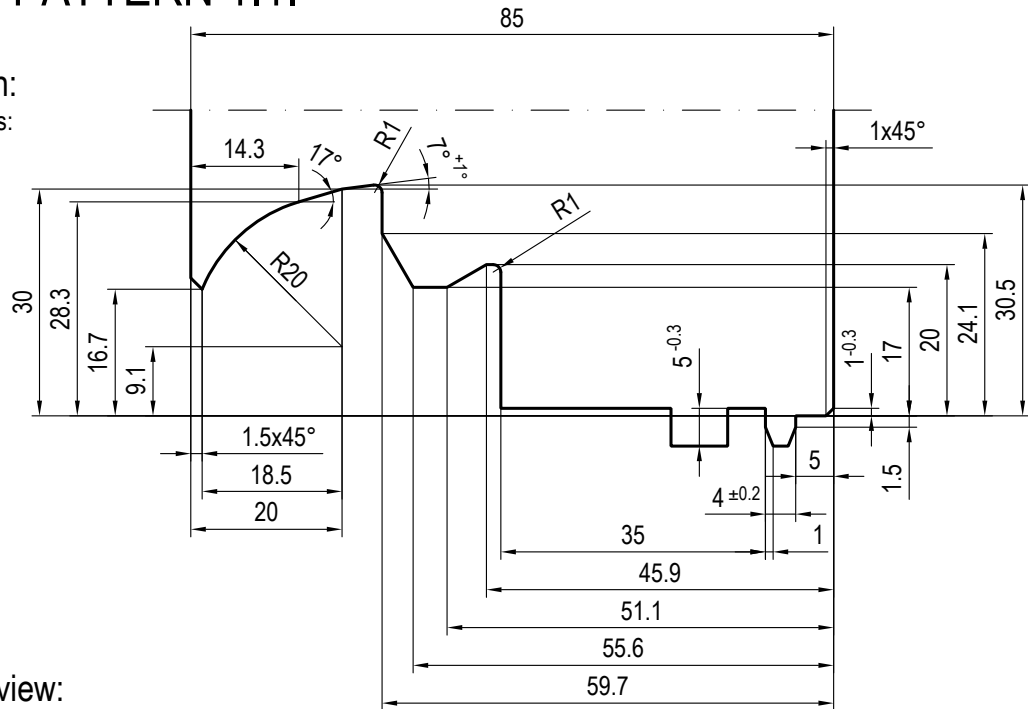

mullion side view:

scale: 1:1

## MILLING PATTERN 1.2.

for mullion on:  
Classic-line profiles:  
- frame  
- mullion

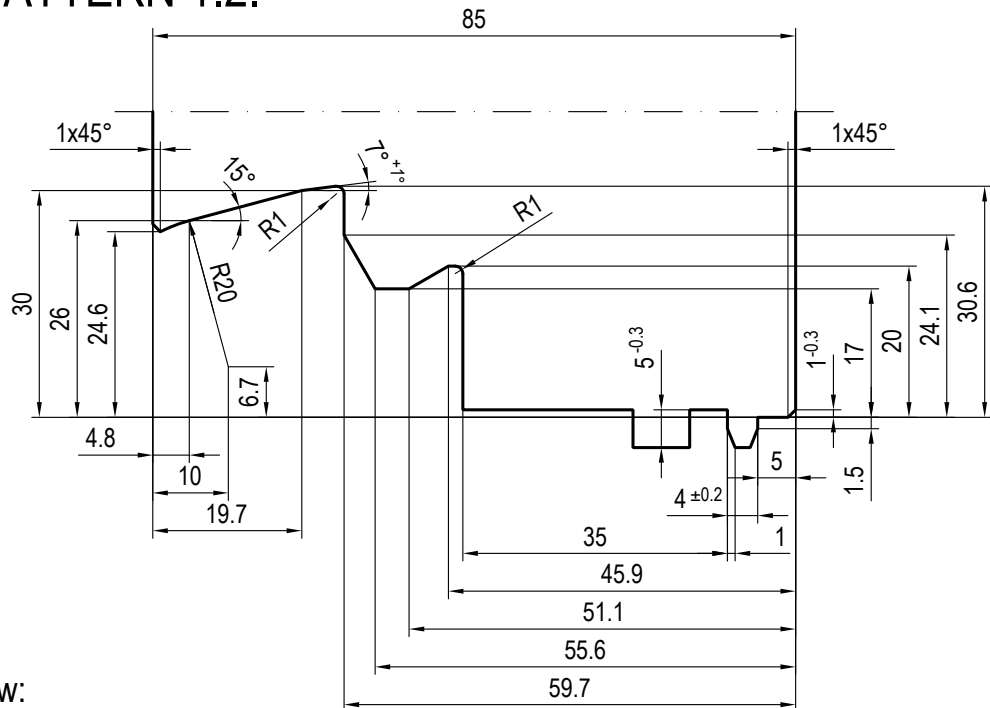

mullion side view:

scale: 1:1

Further milling patterns upon request (contact Engineering Application Department)

## MILLING PATTERN 2.1.

for transom on:

Round-line profiles:

- sash, recessed
- transom, recessed

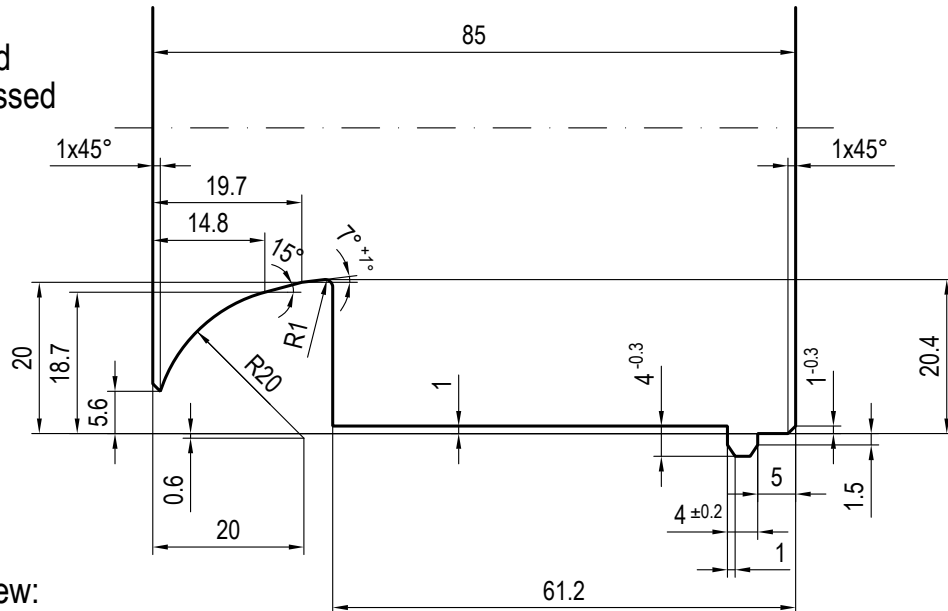

transom side view:

scale: 1:1

## MILLING PATTERN 2.2.

for transom on:

Round-line profiles:

- sash, semi-recessed

Classic-line profiles:

- sash, recessed

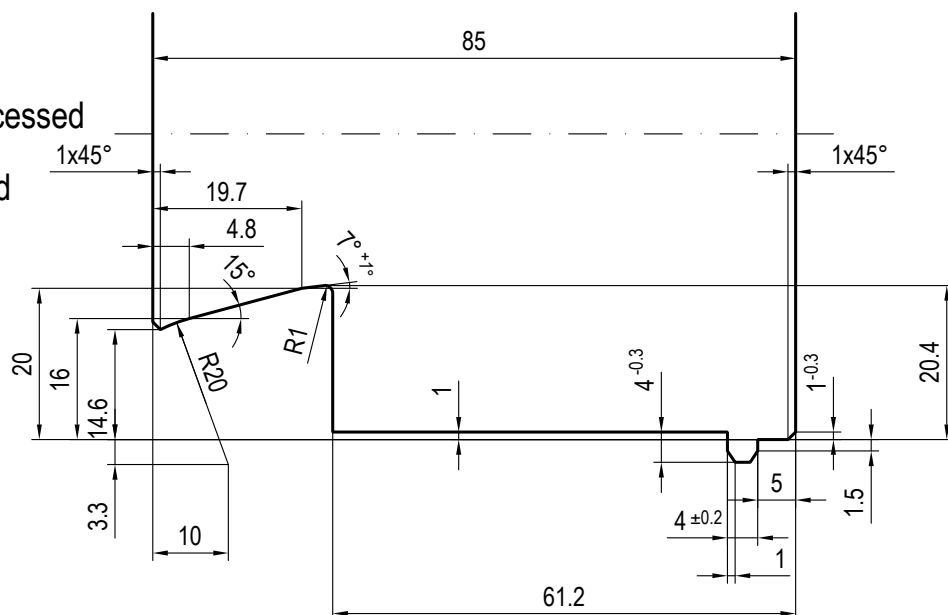

transom side view:

scale: 1:1

Further milling patterns upon request (contact Engineering Application Department)

## Drilling pattern (drilling jig 680900)

Note: Dimensions refer to a drilling without drilling jig!

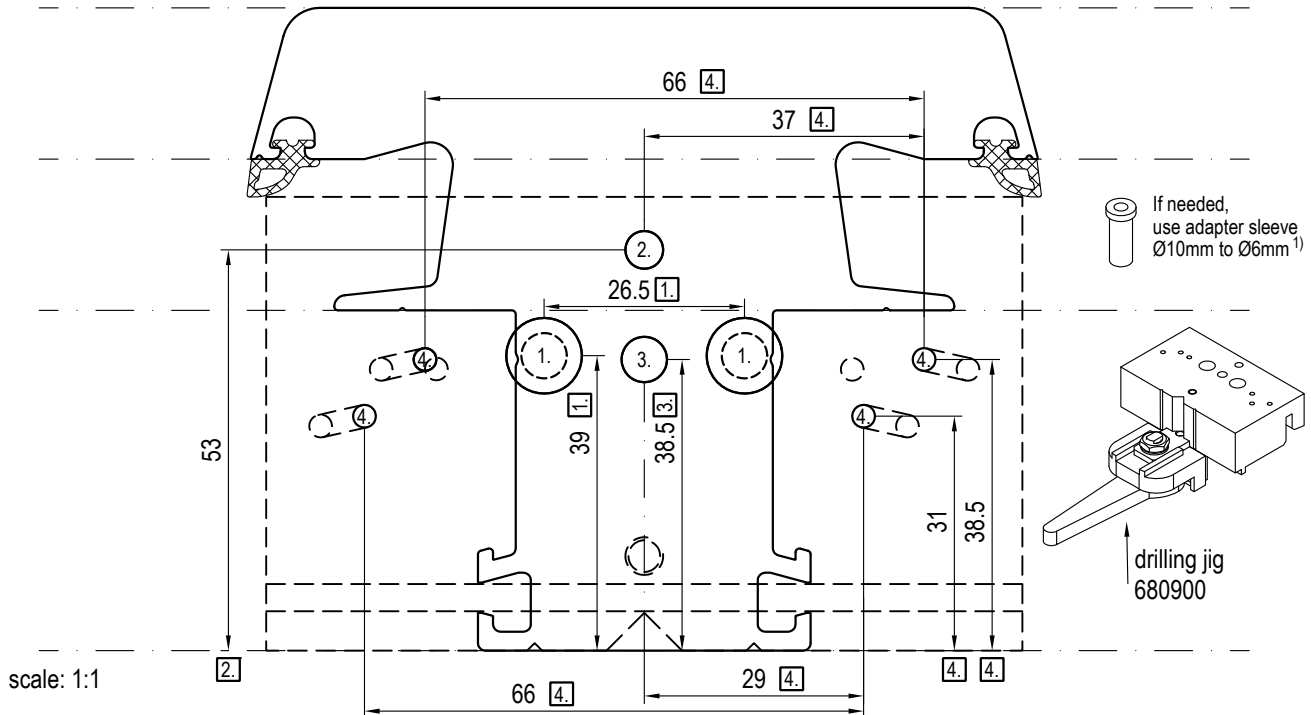

scale: 1:1

### Application of drilling pattern-drill holes

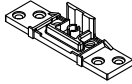
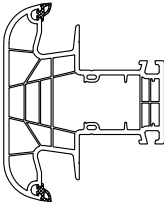
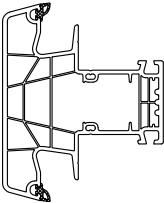
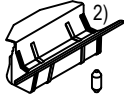
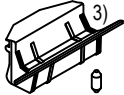
drilling [1]	2x Ø10mm 2x Ø6mm <sup>1)</sup>	standard	-	standard	-	
drilling [2]	1x Ø5mm	standard	standard	standard	standard	
drilling [3]	1x Ø6mm	option	option	option	option	
drilling [4]	4x Ø3mm	-	-	standard	standard	
compatible connector		with sticks 657130	without sticks 657030	with sticks 657134	without sticks 657034	
		metal		metal		
see chapter 09 H:		page 08		page 09		
compatible mullion						
		180x43	180x44			
compatible gasket blocks						
		650032 wh 659032 bl	650033 wh 659033 bl			

<sup>1)</sup> Use step drill 620920 or adapter sleeve Ø10mm to Ø6mm.

<sup>2)</sup> In the case of circumferential gasket

<sup>3)</sup> In the case of non-circumferential gasket

May be subject to change  
and errors excepted!

scale: 1:5  
09\_H\_01\_8\*

Individual Handling: Mechanical Connections  
Drilling Pattern (Drilling Jig 680900) for Mullions

## Drilling pattern

Note: Dimensions refer to a drilling without drilling jig!

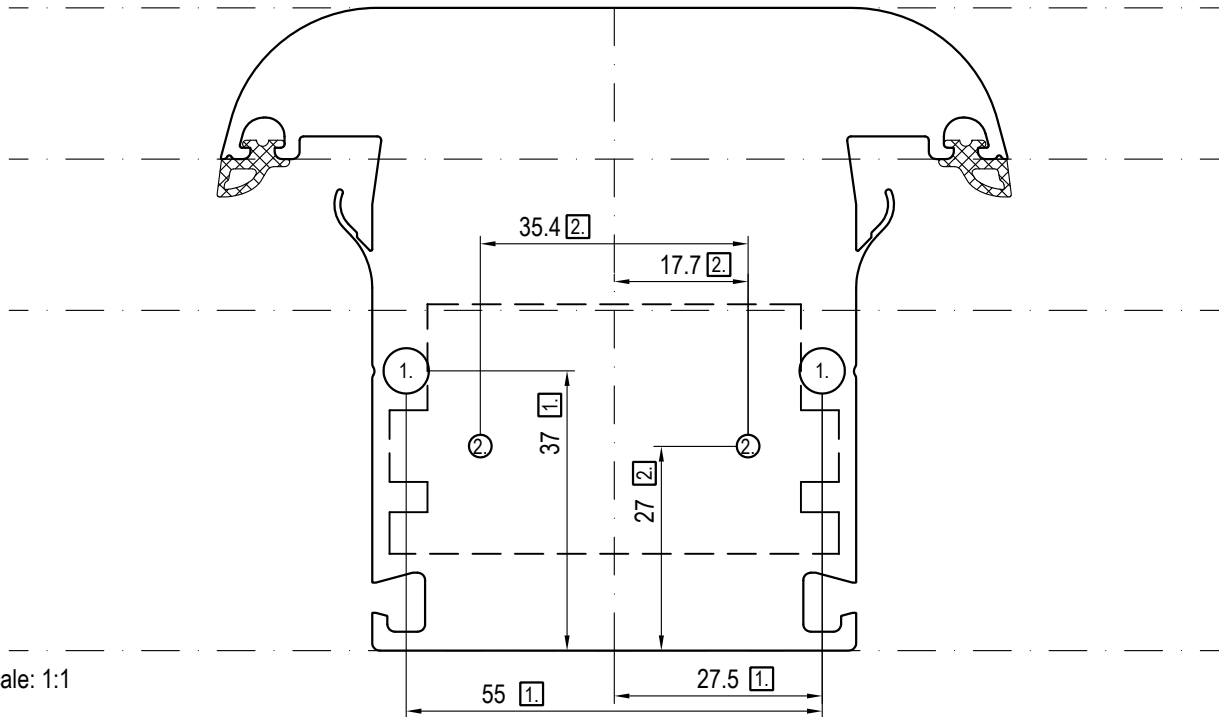

scale: 1:1

### Application of drilling pattern-drill holes

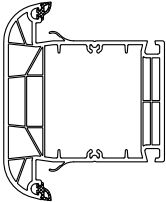
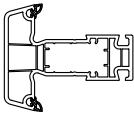
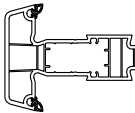
drilling [1]	2x Ø6mm	-	standard	drilling pattern on request (Engineering Application)	
drilling [2]	2x Ø3mm	-	standard		
compatible connector	without sticks -	without sticks 685145		connector on request (Engineering Application)	
see chapter 09 H:	plastic	page 10			
compatible transoms		180x45		180x46	
				180x47	

May be subject to change  
and errors excepted!

scale: 1:5  
09\_H\_01\_8\*

Individual Handling: Mechanical Connections  
Drilling Pattern for Transoms

## Assembly Instruction for Mullion Connector 657130 / 657030\* with Sealing Pad 65x032 / 65x033

The mullion connector may only be used in connection with the proper steel reinforcement (if required) in the sash and the transom!

1. Straight cutting of mullion profile (total mullion length = clear rebate dimension + 8mm) (fig. 1)
2. Contour milling as per milling pattern (fig. 2) (chapter 09 H page 04)
3. Insert reinforcement according to guidelines (total reinforcement length = mullion length - 72mm) (fig.3 and 4)
4. Use the drilling pattern (drilling jig 680900) for mullions to pre-drill the central and the two lateral drill holes in the frame- or mullion rebate (ø5mm in the case of manual screwing or ø6mm in the case of machining centre / for connectors with sticks: drill hole of Ø10mm), as well as to pre-drill a hole of ø5mm in the upper glazing rebate for the pin (included with gasket block 65x032 / 65x033). (fig. 5)
5. Insert gasket profile 65x032 / 65x033 together with the included pin into the upper drill hole. (fig. 6)
- 6.1. Insert mullion profile with the connector into the frame / mullion, align it and fasten it to the frame / mullion with two Spax-screws through the double drill-hole in the frame / mullion. (fig. 7)
- 6.2. Optionally, screw the connector for central fastening with two Spax-screws to the mullion. (fig. 8a)  
Then, screw the mullion including the fixed connector with a self-drilling screw through the central drill hole to the sash / frame (fig.8b).
7. Seal any gasket joints and openings before glazing. (fig. 9)

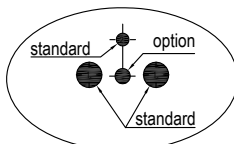
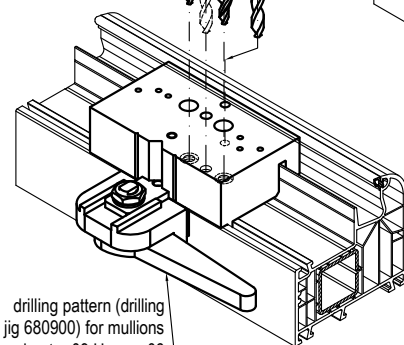
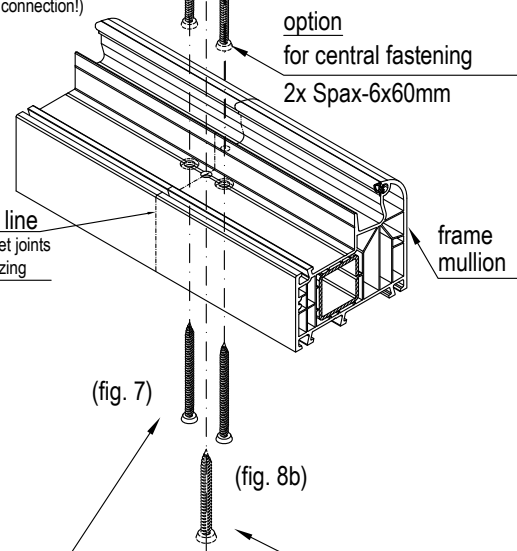
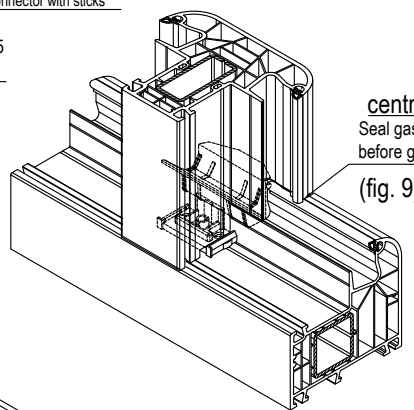
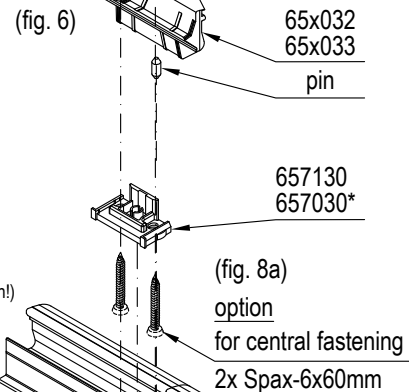
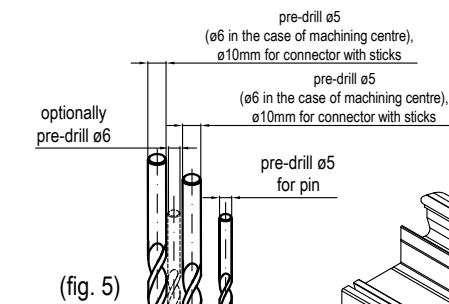
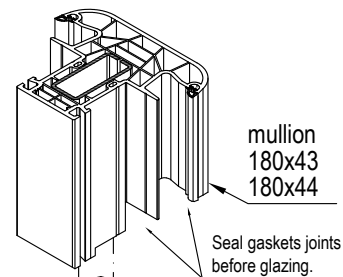
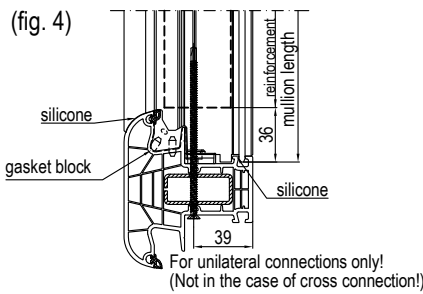
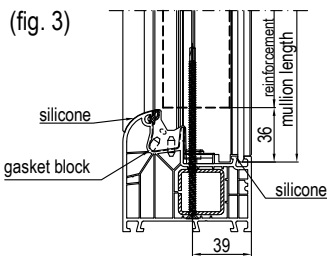
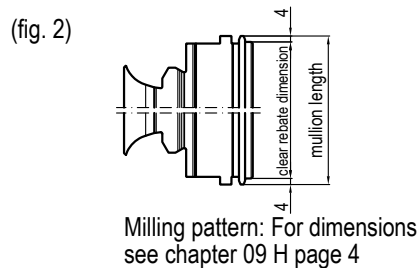
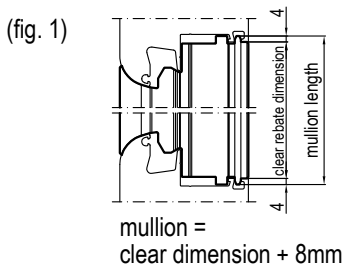

Standard:	F:frame/M:mullion	Option:
2x ABC-Spax	Profile	1x central with self-drilling screw
4.8 x 100mm	M:180x43/180x44	6 x 50mm
4.8 x 110mm	F:080x05/180x03/180x04/180x05	6 x 50mm

Screw lengths apply only with blind hole in the uPVC-profile!

\*without sticks

May be subject to change and errors excepted!

scale: 1:5  
09\_H\_02\_8\*

## Individual Handling: Mechanical Connections

### Connector 657130/657030 for Mullions 180x43/180x44

## Assembly Instruction for Cross Connector 657134 / 657034\* with Sealing Pad 65x032 / 65x033

The mullion connector may only be used in connection with the proper steel reinforcement (if required) in the frame and the mullion!

1. Straight cutting of mullion profile (total mullion length = clear rebate dimension + 8mm) (fig. 1)
2. Contour milling as per milling pattern (fig. 2) (chapter 09 H page 04)
3. Insert reinforcement according to guidelines (total reinforcement length = mullion length - 72mm) (fig.3 and 4)
4. Use drilling pattern (drilling jig 680900) for mullions to pre-drill 4 fastening holes  $\varnothing 3\text{mm}$ , the central and the two lateral drill holes in the frame or mullion rebate  $\varnothing 5\text{mm}$  for manual screwing or  $\varnothing 6\text{mm}$  in the case of machining centre / for connectors with sticks: drill hole  $\varnothing 10\text{mm}$ ). Additionally, pre-drill  $\varnothing 5\text{mm}$  in the upper glazing rebate for the pin (included with gasket block 65x032 / 65x033). (fig. 5)
5. Insert gasket profile 65x032 / 65x033 together with the included pin into the upper drill hole. (fig. 6)
6. In the case of a cross connection, the connector must be screwed to the mullion with two Spax-screws 6x60mm. (fig. 8a)
- 7.1. Option: Insert mullion profile with connector into frame, align it and screw it through the double drill hole in the frame to the frame using two Spax screws. (fig. 7) (Not applicable in the case of cross connection)
- 7.2. Option: in the case of central fastening, see point 6. (fig. 8a) Then, screw the mullion including the fixed connector with a self-drilling screw through the central drill hole to the frame. (fig. 8b) (Not applicable in the case of cross connection)
8. Fasten connector (in the case of cross connection: top and bottom connector) with the fixed mullion to the horizontal mullion using 4 screws at a time (4.2x19mm). (fig. 9)
9. Seal any gasket joints and openings before glazing. (fig. 10)

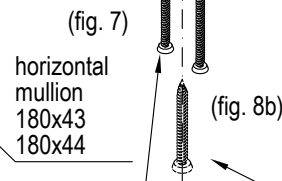
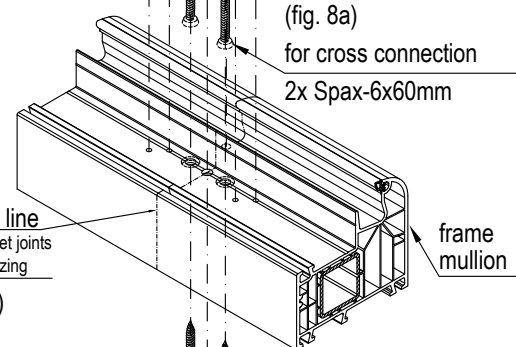
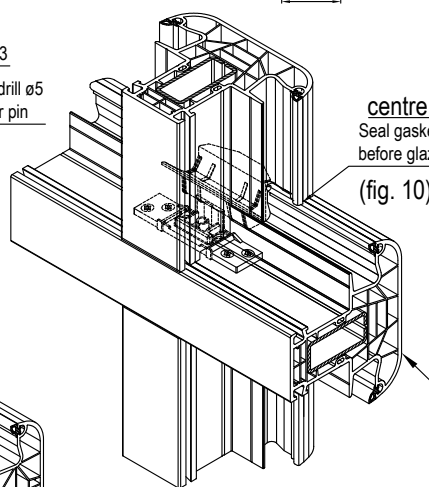
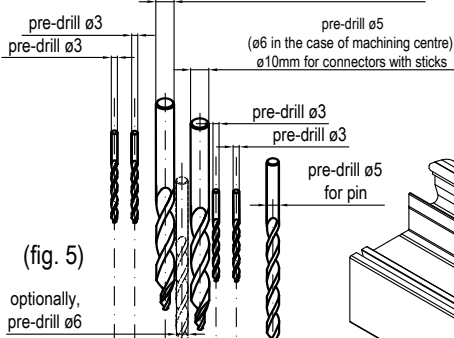
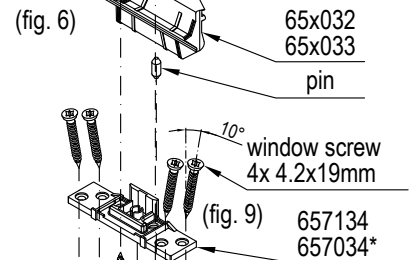
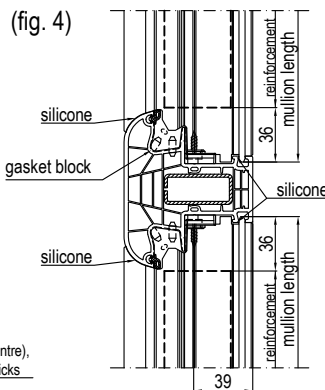
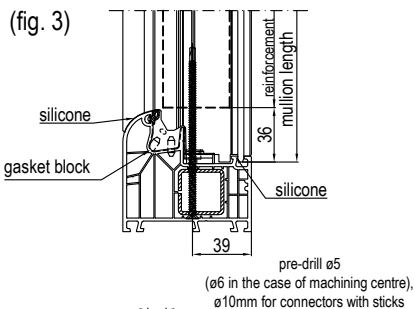
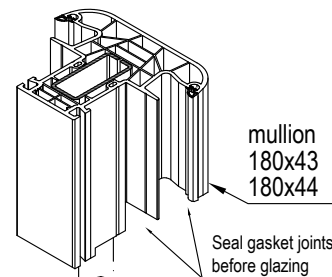
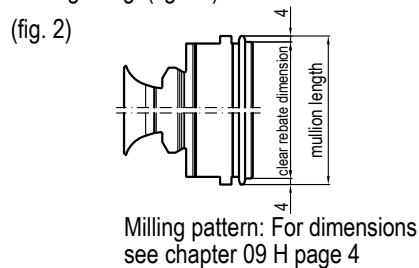
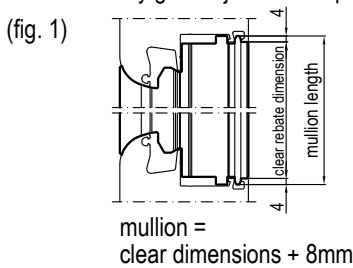

drilling pattern (drilling jig 680900) for mullions chapter 09 H page 06

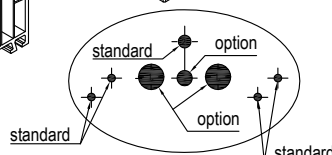

Option:	F:frame/M:mullion	Option:
2x ABC-Spax	Profile	1x central with self-drilling screw
4.8 x 100mm	M:180x43/180x44	6 x 50mm
4.8 x 110mm	F:080x05/180x03/180x04/180x05	6 x 50mm
Screw lengths apply only with blind hole in the uPVC-profile!		

\*without sticks

May be subject to change and errors excepted!

scale: 1:5  
09\_H\_02\_8\*

## Individual Handling: Mechanical Connections

### Connector 657134/657034 for Mullions 180x43/180x44

## Assembly Instruction for Transom Connector 685145

The connector may only be used in connection with the proper steel reinforcement (if required) in the sash and transom profile!  
**!!! Install transom with connector 685145 before welding the element (in the case of smaller elements) !!!**

1. Straight cutting of transom profile (total transom length = clear rebate dimension + 6mm). (fig. 1)
2. Contour milling as per milling pattern (fig. 2) (chapter 09 H page 05).
3. Insert reinforcement according to guidelines (total reinforcement length = transom length - 112mm). (fig. 3 and 4)
4. Use drilling pattern for transoms to pre-drill 2x  $\varnothing 6$ mm in the sash rebate or in the horizontal transom. (fig. 5)
5. Use drilling pattern for transoms to pre-drill 2x  $\varnothing 3$ mm in the sash rebate or in the horizontal transom. (fig. 6)
6. Screw connector 685145 (fig. 7) with 2x ABC-Spax screws from above to the sash or to the horizontal transom. (fig. 8)
7. Place transom onto the connector 685145 which is screwed to the sash or to the horizontal transom (fig. 11). Then, pre-drill laterally on the left and right side  $\varnothing 3$ mm, staggered to the yet existing screw channels in the connector's reach and fasten the transom with one window screw per side. (fig. 9) (Fig. 12 shows the connector's position in the transom.)
8. Then, screw the transom from below through the sash or through the horizontal transom, using 2x ABC-Spax screws. (fig. 10)
9. Seal any gasket joints and openings before glazing (fig. 11) and weld the element.

**Note:** Alternatively, the following three options for a transom connection or cross connection are possible:

- A: V-cut welding: Please contact the aluplast Engineering Application Department!
- B: Butt welding: Please contact the aluplast Engineering Application Department!
- C: Screwing without connector 685145: Assembly Instruction points 5. / 6. / 7. (or fig. 6 / 7 / 8 / 9) do not apply, in contrast to point 3. of the Assembly Instruction (see above) the total reinforcement length = transom length - 56mm.

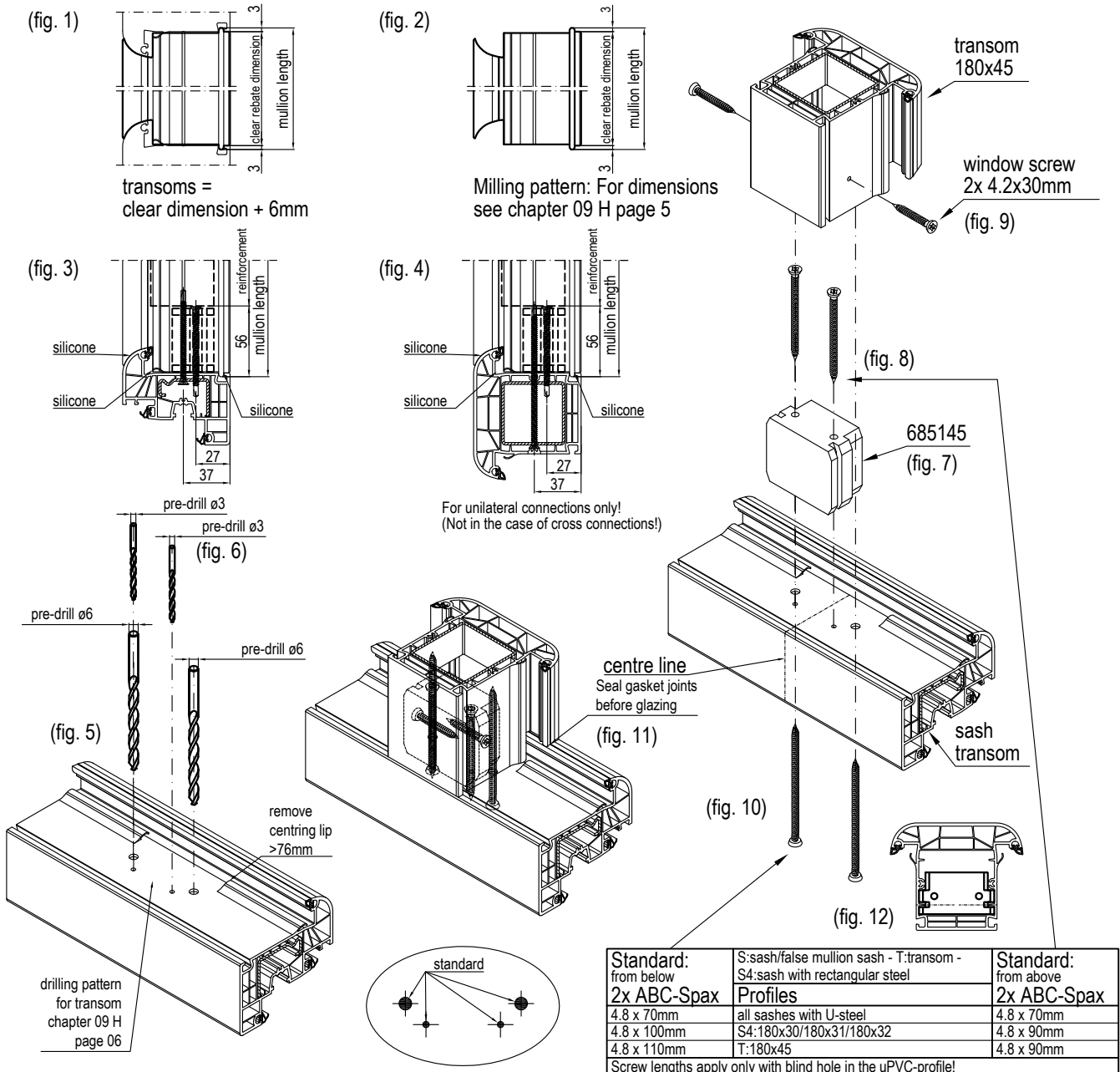

May be subject to change and errors excepted!

scale: 1:5  
 09\_H\_02\_8\*

## Individual Handling: Mechanical Connections

### Connector 685145 for Transom 180x45



## Assembly Instruction for Connection for Door Threshold (frame with 85mm construction depth on threshold)

**ATTENTION:** - Connections for door thresholds may only be assembled in connection with properly reinforced profiles!  
- Thresholds (laterally), any joints, openings, drill-holes etc. must be sealed with silicone!

**NOTE:** Connection for threshold consists of three single elements (A)-(B)-(C) that must be stuck together before assembly.

1. Cut frame (with reinforcement) at the bottom to 90° and weld the frame on three sides, element height -20mm. (fig. 1)
2. Cut threshold: element width -10mm (2x -5mm). (fig. 2)
3. Screw connection for threshold laterally to threshold: 2x FD2 3.9 x 32mm. (fig. 3)
4. Screw connection for threshold from above to the threshold: 1x FD2 3.9 x 16mm. (fig. 4)  
If needed, pre-drill  $\varnothing 2\text{mm}$ .
5. Place welded frame (optionally with assembled mullion\*) on the threshold with the assembled connection for threshold. (fig. 5)
6. Screw connection for threshold to the back of the frame: 2x FD21 3.9 x 32mm. (fig. 6)
7. Screw connection for threshold to the frame rebate: 1x FD21 3.9 x 32mm. (fig. 7)
8. Insert windstop (446091) into frame (optionally also into assembled mullion\*) and accordingly, insert windstop (446092) into the sash opposite windstop 446091. (fig. 8)

CD**	profile serial
85mm	IDEAL 8000

\*\*construction depth

frame	connection th.***
080x05	
080x05	686071
180x03	686070

\*\*\*connection for threshold

threshold h= 20mm	
85mm	269060
120mm	249058

2X	FD2	3.9 x 16mm	
4X	FD2	3.9 x 32mm	
6X	FD21	3.9 x 32mm	
drill $\varnothing 2\text{mm}$ (option)			

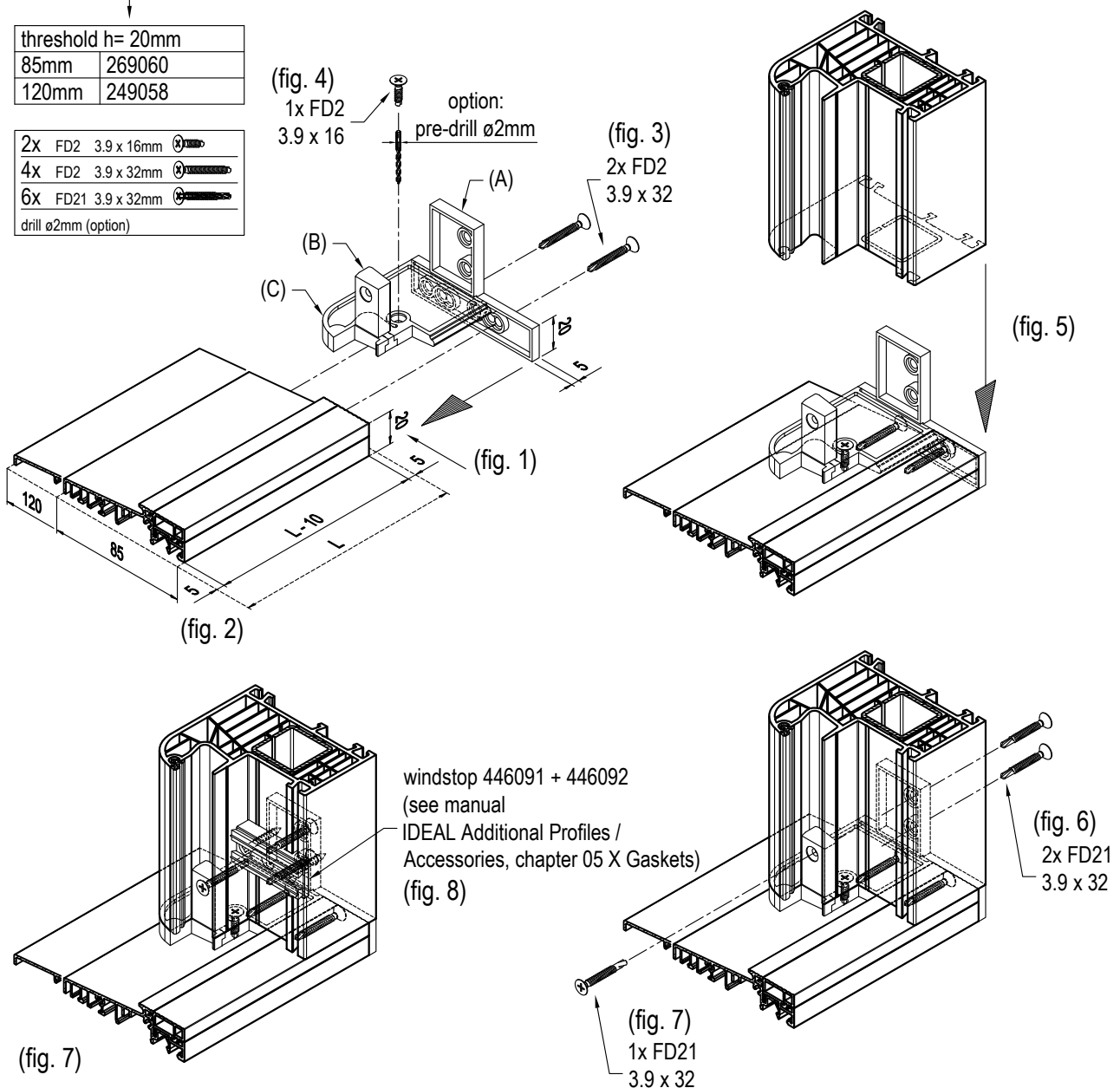

\* Mullion coupler: See Assembly Instruction Mullion Coupler (mullion with 85mm construction depth on thresholds).  
(Example with) frame 180x03 - thresholds 249058, 269060 - connection for threshold 686070

May be subject to change and errors excepted!

scale: 1:4  
09\_J\_01\_8\*

Individual Handling: Thresholds / Doors  
Thresholds: Connection for Threshold

## Assembly Instruction for Mullion Coupler (mullion with 85mm construction depth on threshold)

- ATTENTION:** - The mullion coupler may only be assembled in connection with properly reinforced profiles!  
 - Thresholds (laterally), any joints, openings, drill-holes etc. must be sealed with silicone!
- NOTE:** Mullion coupler consists of three single elements (A)-(B)-(C) that must be stuck together before assembly.





1. Prepare frame and connection for threshold. For further information see Assembly Instruction for Connection for Thresholds.
2. Cut mullion (with reinforcement) at the bottom to 90°, element height -20mm. (fig.1)  
 Deduction dimensions must be observed! For further information see chapter 09 H Mechanical Connections between Mullion and Frame.
3. Screw mullion coupler from above to the threshold: 2x FD2 3.9 x 16mm. (fig. 2) If needed, pre-drill  $\varnothing 2$ mm.
4. Drill two times  $\varnothing 4$ mm from above through threshold through the screw channels in the mullion coupler. (fig. 3)

CD**	profile serial
85mm	IDEAL 8000

\*\*construction depth ↓

mullion	mullion coupler
180x43	686072
180x44	686073

threshold h= 20mm	
85mm	269060
120mm	249058

2X	FD2	3.9 x 16mm	
2X	FD21	3.9 x 25mm	
2X	4.2 x 40mm		
	drill $\varnothing 4$ mm		
	drill $\varnothing 2$ mm (option)		

5. Install mullion with coupler at the top in the welded frame: For further information see chapter 09 H Mechanical Connections.
6. Place welded frame with assembled mullion on the threshold with the assembled connection for threshold. (fig.4)
7. Screw frame to connection for threshold. For further information see Assembly Instruction for Connection for Threshold.
8. Screw mullion coupler to mullion rebate on left and right side: on each side 1x FD21 3.9 x 25mm. (fig.5 a + b)
9. Screw mullion from below through threshold and mullion coupler: 2x 4.2 x 40mm. (fig. 6)
10. Insert windstop (446091) into mullion on left and right side, and accordingly, insert windstop (446092) into the corresponding sash opposite windstop 446091 (not required for fixed glazing). (fig.7)

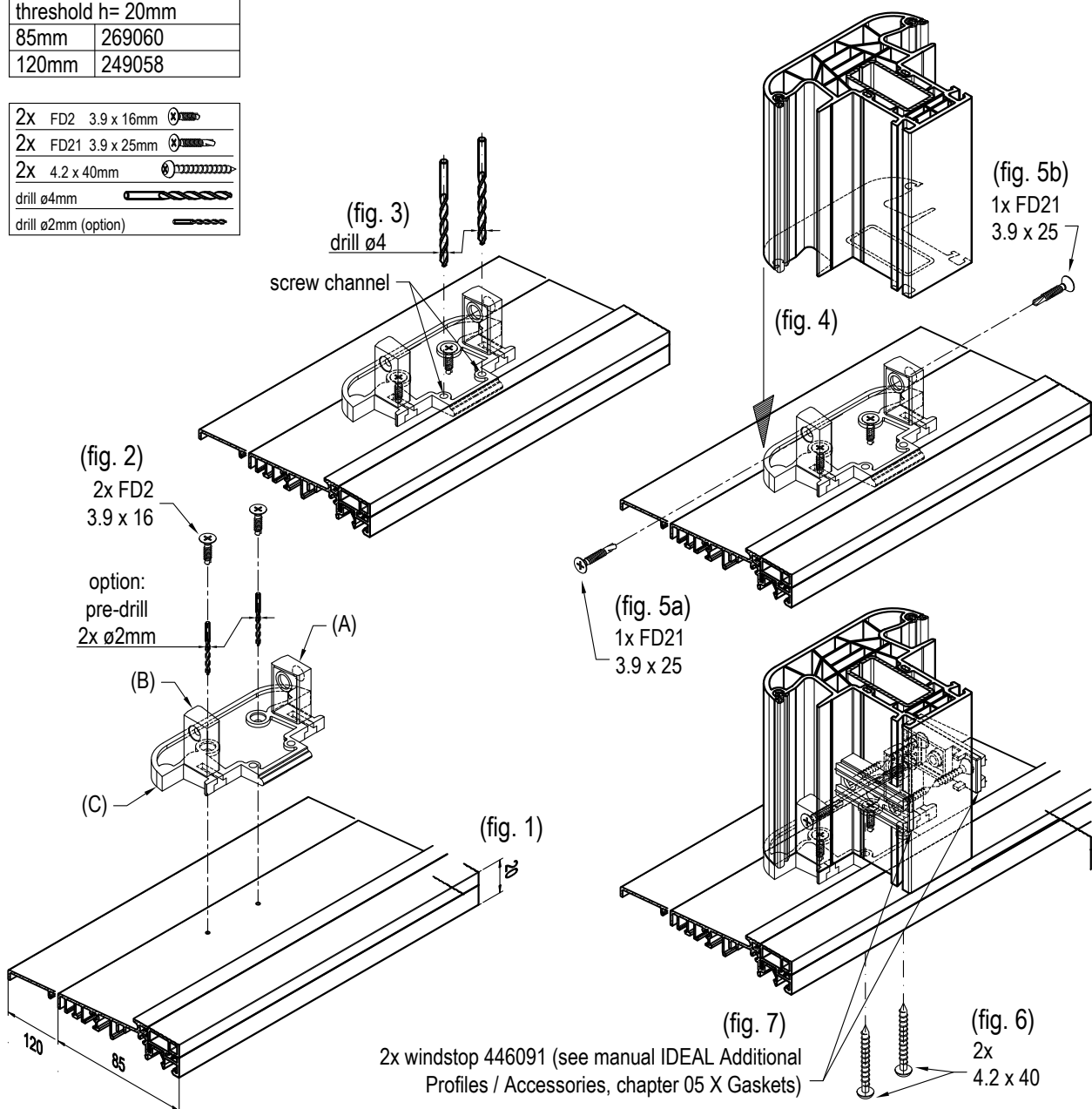

(Example with) mullion 180x43 - threshold 249058, 269060 - connection for threshold 686072

May be subject to change and errors excepted!

scale: 1:4  
 09\_J\_01\_8\*

Individual Handling: Thresholds / Doors  
 Thresholds: Mullion Coupler

## Assembly Instruction Tilt-and-Turn Threshold: Weather Bar

### One sash (no drawing):

1. Cut weather bar:  $L = FIF - 50$
2. Screw end caps: FD2 3.9 x 16mm or FD21 3.9 x 19mm.
3. Cut sealing profile  $L = FIF - 24$
4. Assemble weather bar including the end caps and sealing profiles.
5. Seal laterally.

### French Casement Window (two sashes + false mullion) (see drawing/ example):

1. Cut weather bar of turn- and tilt+turn sash according to drawing!
2. Screw end caps: FD2 3.9 x 16mm or FD21 3.9 x 19mm.
3. Notch weather bar of turn sash including end cap at false mullion end cap by about 1.5mm (detail "A").
4. Cut sealing profile of turn- and tilt+turn sash according to drawing!
5. Assemble weather bar including end caps and sealing profile.
6. Seal laterally and at false mullion end cap.

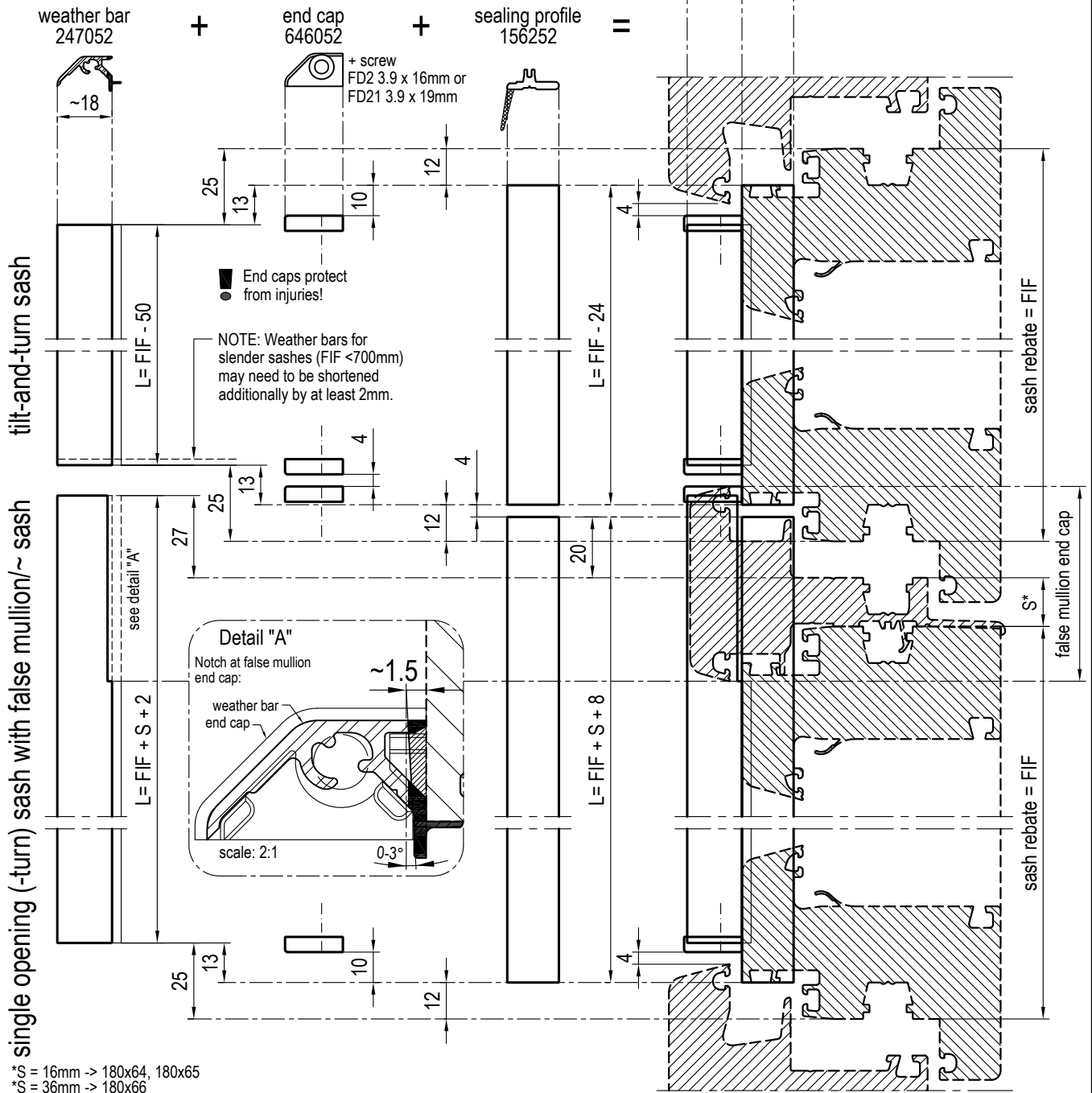

(Example with) frame 080x05/180x05 - sash 180x20 - false mullion 180x65 - false mullion end cap 680065 - threshold 269060

May be subject to change and errors excepted!

scale: 1:2  
09\_J\_01\_8\*

Individual Handling: Thresholds / Doors  
Tilt-and-Turn Thresholds: Weather Bars

## horizontal section

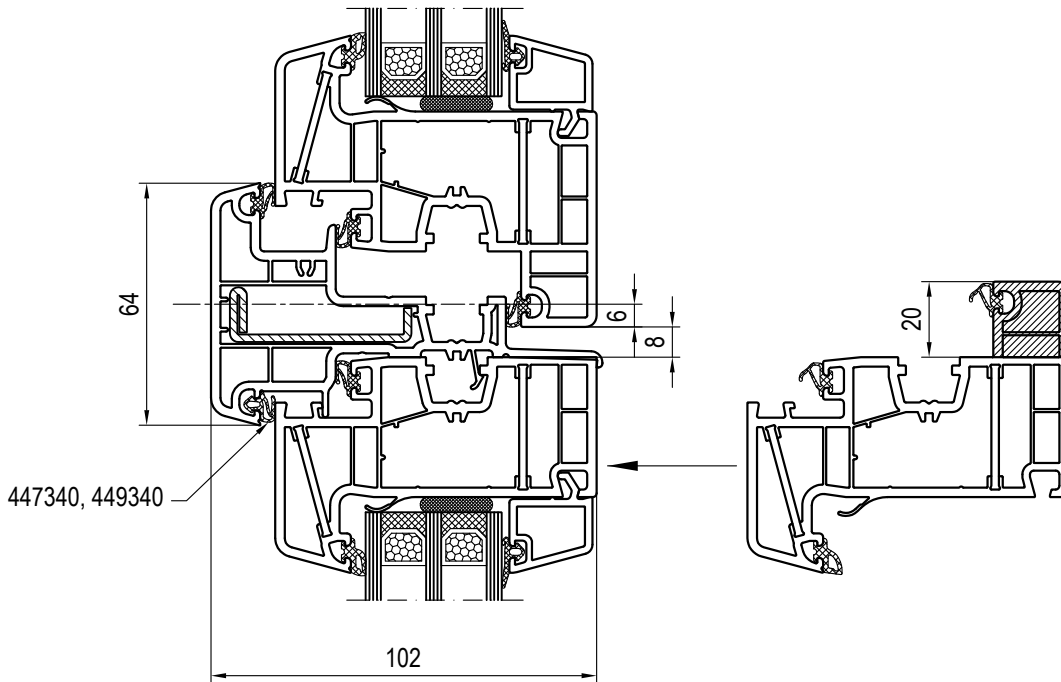

## vertical section

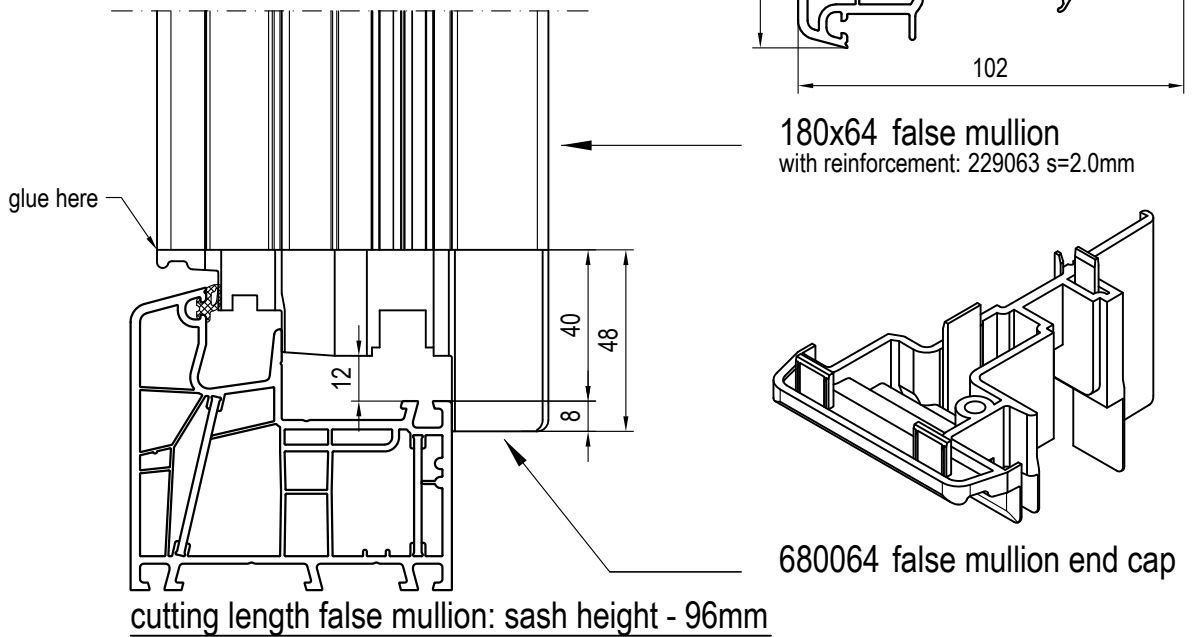

(example with) frame 080x05 - sash 080x86

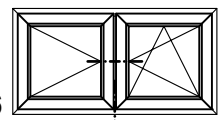

May be subject to change  
and errors excepted!

scale: 1:2  
09\_Z\_01\_8\*

## Individual Handling: Cutting Dimensions False Mullion False Mullion 180x64

## horizontal section

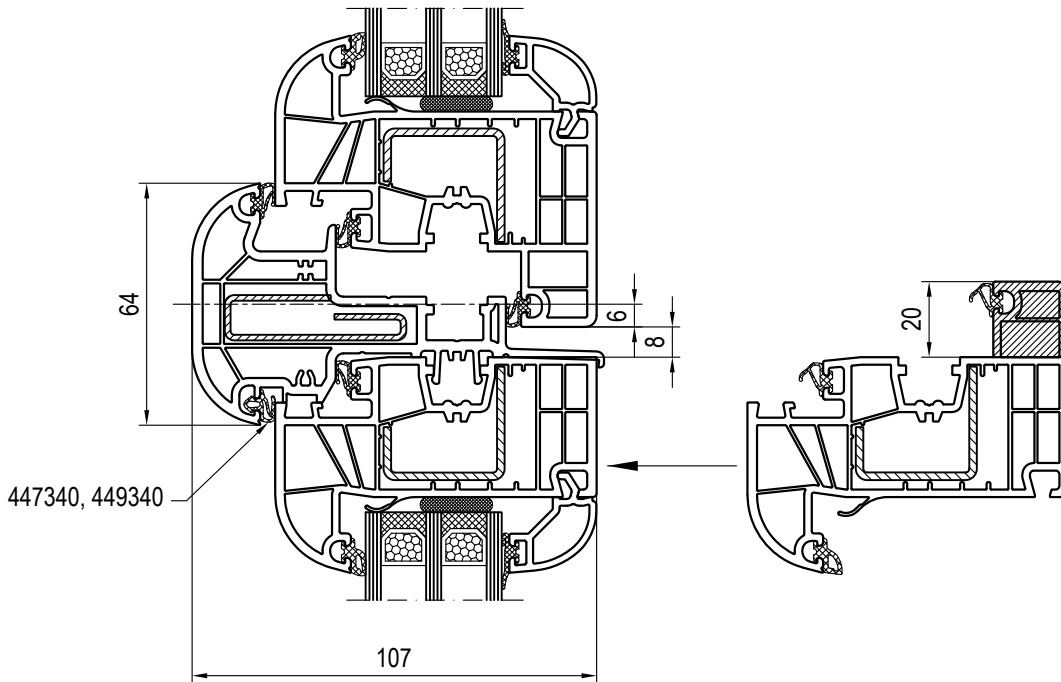

## vertical section

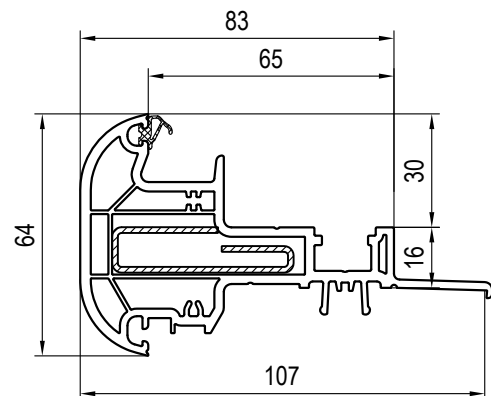
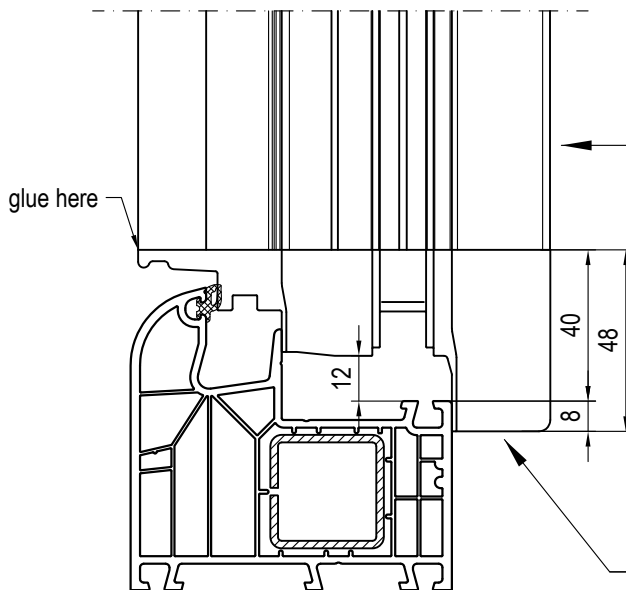

**180x65 false mullion**  
with reinforcement: 249190 s=1.5mm

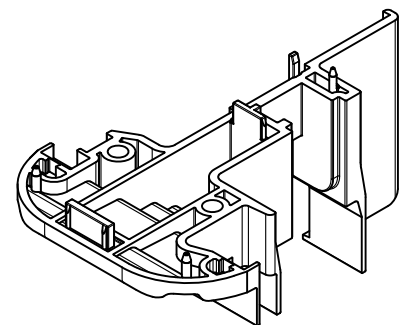

**680065 false mullion end cap**

cutting length false mullion: sash height - 96mm

(example with) frame 180x03 - sash 180x83

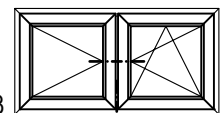

May be subject to change  
and errors excepted!

scale: 1:2  
09\_Z\_01\_8\*

## Individual Handling: Cutting Dimensions False Mullion

### False Mullion 180x65

## horizontal section

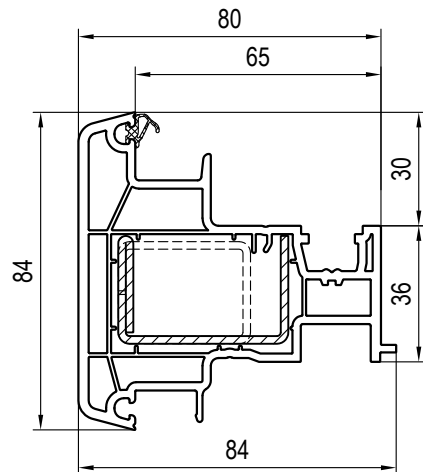
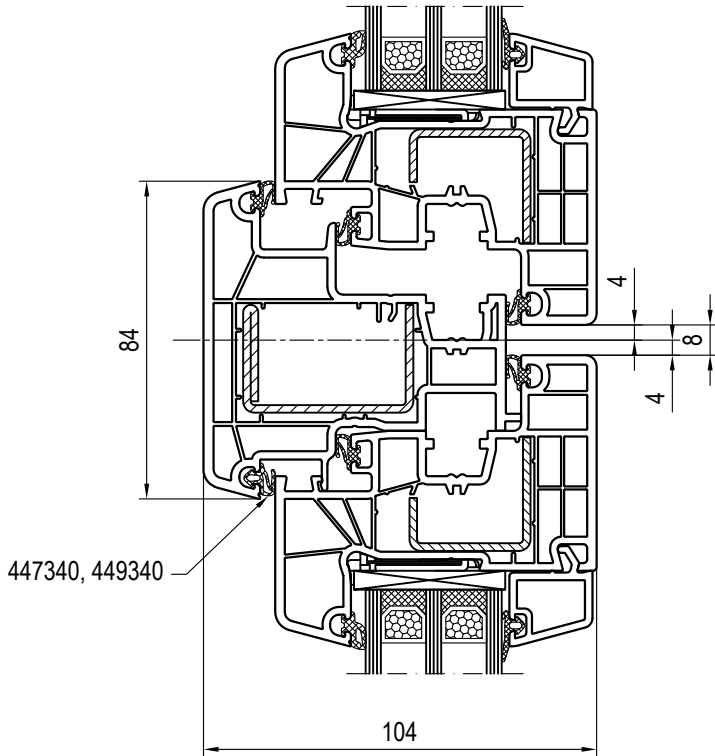

## vertical section

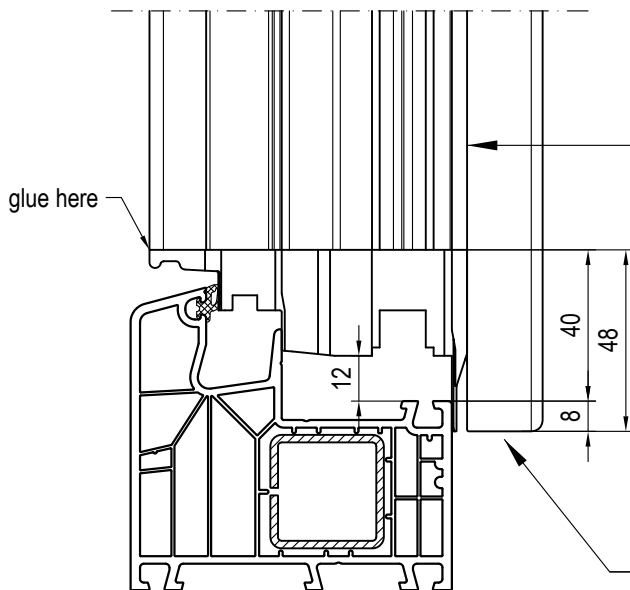

**180x65 false mullion**  
with reinforcement: 229029 s=1.25mm  
229030 s=2.0mm  
289066 s=2.0mm

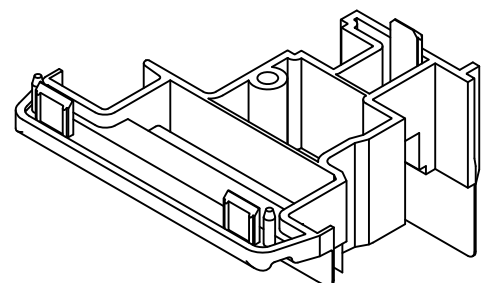

**680066 false mullion end cap**

cutting length false mullion: sash height - 96mm

(example with) frame 180x05 - sash 180x20

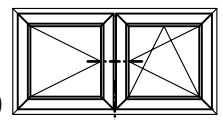

May be subject to change  
and errors excepted!

scale: 1:2  
09\_Z\_01\_8\*

## Individual Handling: Cutting Dimensions False Mullion

### False Mullion 180x66

1. Weld reinforced false mullion sash (1x vertically) to reinforced sashes (3 sides).
2. Cut out a square of 49 x 49mm from the two corners of false mullion sash - sash.
3. Insert and screw false mullion end caps 680029 (set).

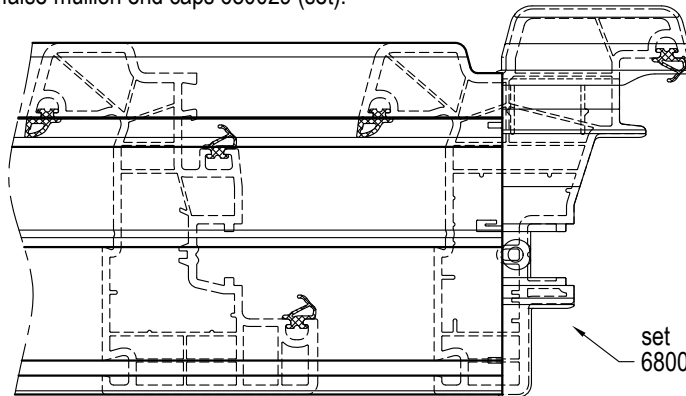

top view

set  
680029 false mullion end cap

set  
680029 false mullion end cap

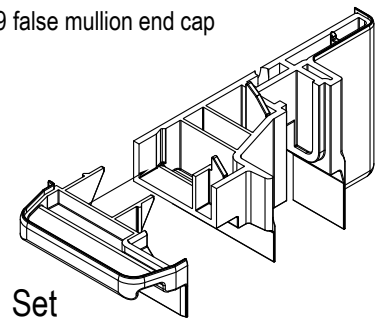

Set  
680029 false mullion  
end cap

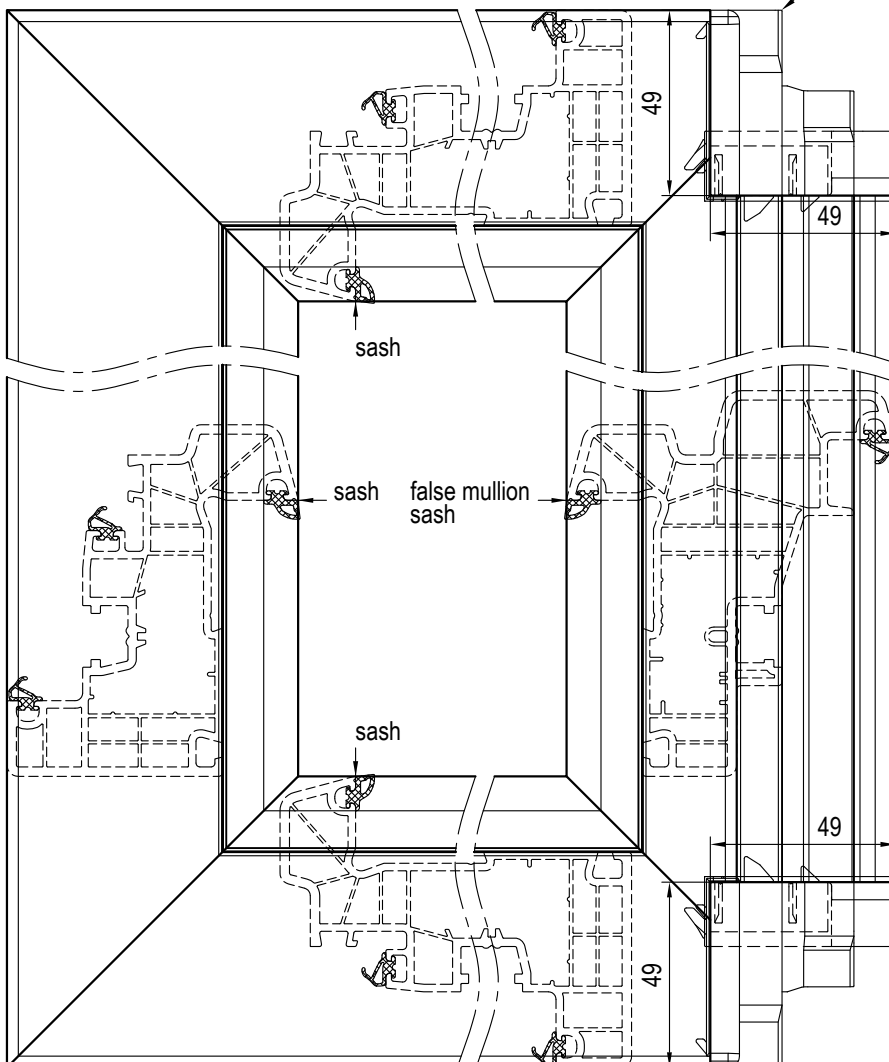

front view (from inside)

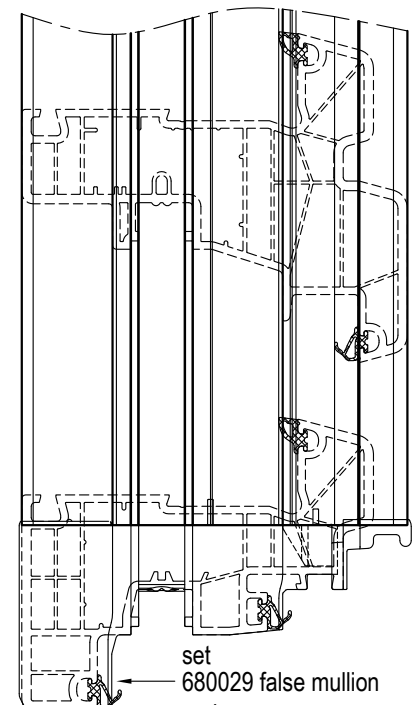

side view

set  
680029 false mullion end cap

(example with) false mullion sash 180x69 - sash 180x26

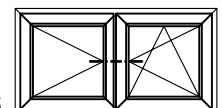

May be subject to change  
and errors excepted!

scale: 1:2  
09\_Z\_01\_8\*

## Individual Handling: Cutting Dimensions False Mullion False Mullion Sash 180x69